



**MASIERO**<sup>®</sup>

**ECLETTICA**



I

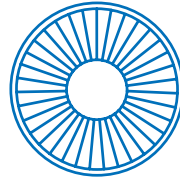

S



O

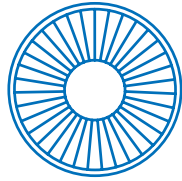

R

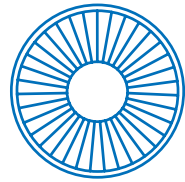

M



E

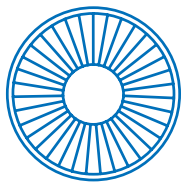

I



S

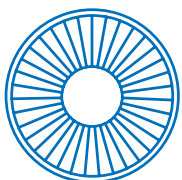
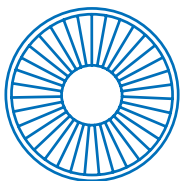

A



R



I

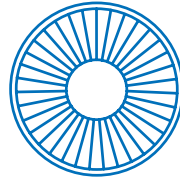

S



O

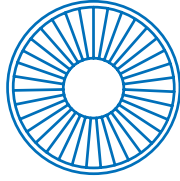

R

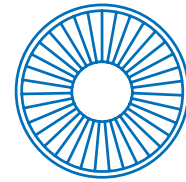

M



E

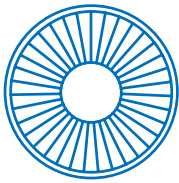

I



S

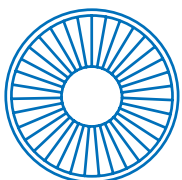
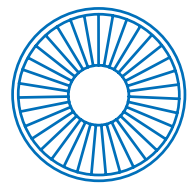

A



R



I

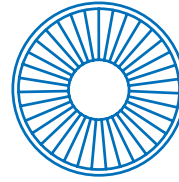

S



O

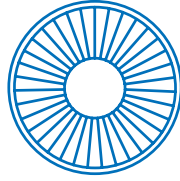

R

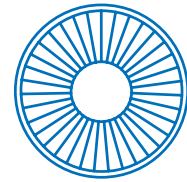

M



E

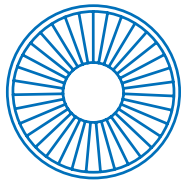

I



S

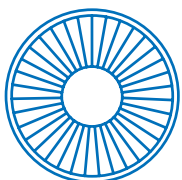
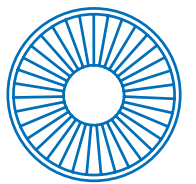

A



R



I

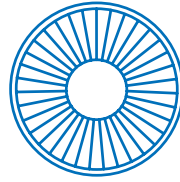

S



O

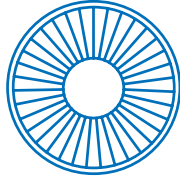

R

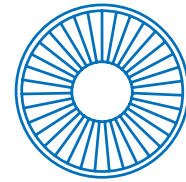

M



E

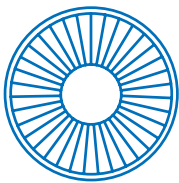

I



S

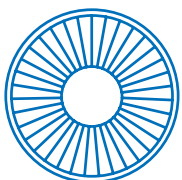
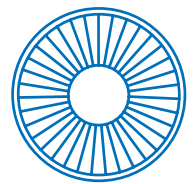

A



R

# SOSPESI NEL TEMPO—

Ma il tempo è ciclico: una storia di eterni ritorni? Oppure è lineare: una freccia sparata dal buio fondo del passato agli abissi incandescenti del futuro? Importa davvero stabilirlo?

La risposta è no.

Anzi NO, tutto in maiuscole.

L'estetica contemporanea, pixellata e in streaming continuo, è fatta di compresenze, innesti, inaudite congiunzioni.

Tradizione e innovazione, ornato e linearità, semplificazione e decoro, percepiti una volta come categorie inconciliabili, sono oggi direttrici che si intersecano, creando nuovi, eccitanti scenari nei quali presente e passato si sovrappongono.

Classico non è più l'opposto di moderno. Semplicemente perché il moderno, quando è veramente tale, cattura lo spirito dei tempi sublimandolo in un segno atemporale, dunque classico; e così il classico, in quanto fuori dal tempo, è moderno.

La conciliazione degli opposti è il valore. Un progetto riuscito rompe il ciclo in una sintesi: è sospeso, al di sopra e al di fuori del tempo.

Masiero ne è la prova.

**MASIERO**

## SUSPENDED IN TIME—

What about time: is it cyclical, an eternal comeback?  
Or is it linear, an arrow propelled from the darkness of the past to the bright abysses of the future? Is there really an urge to define?

The answer is no. NO, all in capitals. Composed of a copious amount of pixels in endless streaming, contemporary esthetic relies on simultaneous presences, crossings, challenging conjunctions. Overlap creating new, exciting scenarios in which past and present are one. Classic is not anymore the polar opposite of modern, simply because modern, when it really is modern, catches and sublimates the zeitgeist in a timeless sign which is intimately classic; classic, on the other hand, when timeless, is resolutely modern. Conciliation of opposites is a value. A successful project breaks the cycle in a synthesis suspended above and out of time.

Masiero offers proof.

## SUSPEDUS DANS LE TEMPS—

Mais le temps est cyclique : serait-ce une histoire d'éternels retours?  
Ou bien est-il linéaire: une flèche lancée du fond obscur du passé jusqu'aux abysses incandescentes du futur?  
Est-il vraiment important de le savoir?

La réponse est non. Ou plutôt NON, en majuscules. L'esthétique contemporaine, pixelisée et en streaming constant, est faite de coprésences, greffes, conjunctions inouïes. Tradition et innovation, ornements et linéarité, simplification et noblesse, jadis perçus comme des catégories inconciliables, sont aujourd'hui des lignes directrices qui s'entrecoupent, créant de nouveaux scénarios excitants où le présent et le passé se superposent. Classique n'est plus l'opposé de moderne. Tout simplement parce que le moderne, quand il l'est vraiment, capture l'âme des temps l'élevant en un signe atemporel, donc classique; ainsi le classique, hors du temps, est moderne. La conciliation des opposés est la valeur. Un projet réussi rompt le cycle en une synthèse il est suspendu, au-dessus et hors du temps.

Masiero en est la preuve.

## IN DER ZEIT SCHWBEN—

Doch die Zeit ist ein Kreislauf: eine Geschichte der ewigen Wiederkehr?  
Oder sie ist geradlinig: ein aus dem tiefsten Dunkel der Vergangenheit in die glühenden Abgründe der Zukunft abgeschossener Pfeil?  
Ist es wirklich wichtig, das festzulegen?

Die Antwort ist nein. Oder besser noch, NEIN, in Großbuchstaben. Die zeitgemäße Ästhetik, aus Pixeln und in kontinuierlichem Streaming, besteht aus gleichzeitiger Anwesenheit, Einfügungen, außerordentlichen Verbindungen. Tradition und Innovation, Schmuck und Geradlinigkeit, Vereinfachung und Verzierung, einst für unvereinbare Kategorien gehalten, sind heute Leitlinien, die sich kreuzen, und neue, aufregende Szenarien schaffen, in denen sich Gegenwart und Vergangenheit überlagern. Klassisch ist nicht mehr das Gegenteil von modern. Einfach deshalb, weil das Moderne, wenn es das wirklich ist, den Geist der Zeit einfängt und ihn in einem zeitlosen, und damit klassischen Ausdruck veredelt; und so ist das Klassische, da es außerhalb der Zeit liegt, modern. Die Bedeutung liegt in der Aussöhnung der Gegensätze. Ein gelungenes Projekt unterbricht den Kreislauf in einer Synthese: es schwebt, steht über und liegt außerhalb der Zeit.

Masiero ist ein Beweis dafür.

## SUSPENDIDOS EN EL TIEMPO—

Pero, ¿el tiempo es cíclico: una historia de eternos retornos?  
¿O es lineal: una flecha disparada desde el oscuro fondo del pasado a los abismos incandescentes del futuro? ¿Realmente importa determinarlo?

La respuesta es no. Es más NO, con mayúscula. La estética contemporánea, pixelada y en flujo continuo está hecha de concomitancias, acoplamientos, uniones inauditas. Tradición e innovación, adorno y linealidad, simplificación y decoración, percibidos un tiempo como categorías irreconciliables hoy son directrices que se cruzan creando nuevos y excitantes escenarios en los que el presente y el pasado se superponen. Lo clásico ya no es lo contrario de lo moderno. Simplemente porque lo moderno, cuando lo es realmente, captura el espíritu de los tiempos sublimándolo en un signo atemporal y por tanto clásico; y de este modo lo clásico, en la medida en que está fuera del tiempo, es moderno. La conciliación de los opuestos es el valor. Un proyecto logrado rompe el ciclo en una síntesis: está suspendido, por encima del tiempo y más allá de él. Masiero es la prueba.







130 ANIMA



158 ARTÈ



244 AUREA



74 BLINK

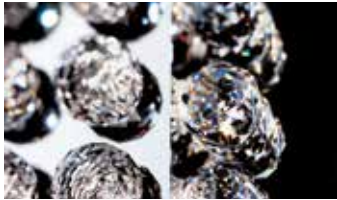

258 CUBIX



82 DROPOP



66 EMPIRE



146 EVA



32 MABELL



222 MIR



170 OLÀ



24 PALM



60 TIEPOLO



50 VIRGO



230 **BLOB**



112 **BLOSSOMY**



10 **BOOL**



118 **BOTERO**



104 **FLASHWOOD**



92 **LIBE**



236 **KIOCCIA**



20 **KIRK**



42 **RIPPLE**



138 **SASSO**



214 **SLIM**



186 **TESSUTI**



# E C'È TUTTO. IL PASSATO, IL FUTURO E LO SCAVARE DENTRO LA MENTE PER PORTARE ALLA LUCE QUELLO CHE È DENTRO DI NOI, MA CHE NON ABBIAMO MAI VISTO—

Non è facile guardare avanti verso il futuro, eppure la linea Masiero in qualche modo anticipa forme di design che sono ancorate al passato, ma guardano verso il nuovo.

E' una ricerca di linee nuove che si intrecciano, sovrappongono, oltrepassano lo stile più classico, ma senza mai negare la continuità e le proprie radici.

Lampadari in stile "minimalista" con tutto quello che il termine significa a partire dagli anni '60 in poi. Minimalista è la sobrietà della forma che nel suo essere scarno vuole solo mostrare ciò che è. Ma minimalista è anche tutto quello che inevitabilmente l'oggetto ci comunica e tutto ciò che noi vogliamo vedere nell'oggetto.

Minimalista sembra la negazione dell'arte e pare che quasi tutti noi, con un po' di fantasia, sia possibile eguagliare se non fosse che i "codici" del minimalismo hanno tale complessità e particolarità – rispetto

ad esempio al linguaggio puramente figurativo – che solo ore di lacrime e sangue possono generare.

E i "codici" non si colgono a colpo d'occhio, ma con l'intuizione della mente, di categorie concettuali: "cose che voi umani non potreste immaginarvi".

Cose che chi ha penetrato i segreti del futuro non può comunicare perché il futuro non ci appartiene. Ma la linea Masiero riesce a comunicare perché lega e salda il futuro col passato e il passato ci è dentro. E' la lampada al laser nel tinello marrone del Dr. Freud nella Vienna di inizio '900.

*E c'è tutto. Il passato, il futuro e lo scavare dentro la mente per portare alla luce quello che è dentro di noi, ma che non abbiamo mai visto.*

ENG

**IT IS EVERYTHING.  
PAST, FUTURE AND DIGGING INTO THE MIND TO BRING TO  
LIGHT WHATEVER IS INSIDE US BUT WHICH WE HAVE NEVER  
SEEN BEFORE—**

It is not easy to look to the future, but somehow the Masiero line is in the vanguard of new designs that are rooted in the past but look ahead. It is a research into new lines that interweave, overlap and exceed the most classic of styles without ever denying continuity and their roots. Minimalist lamps, with everything the term has meant since the beginning of the 60s. Minimalist means sober forms which in their simplicity show all of themselves, but minimalist is also everything that the item communicates and everything we want to see in it. Minimalist seems the negation of art and it seems that all of us, with a bit of imagination, can equal it if it were not for the fact that the minimalist "codes" are extremely complex and peculiar – with respect to the purely figurative language for example – that only hours of tears and blood can create. The "codes" are not grasped at a simple glance but through mental intuition and conceptual codes: "things that you humans could never imagine". Things that whoever has penetrated the secrets of the future cannot communicate to us, because the future does not belong to us. But the Masiero line gets the message over because it ties and welds the future to the past and the past is inside us. Laser lamps in Dr. Freud's brown bath in Vienna at the beginning of the 20th century.

FR

**ET TOUT EST PRÉSENT.  
LE PASSÉ, LE FUTUR ET LA CAPACITÉ DE CREUSER DANS  
L'ESPRIT POUR PORTER À LA LUMIÈRE CE QU'IL Y A EN NOUS,  
MAIS QUE NOUS N'AVONS JAMAIS VU—**

Il n'est pas facile de regarder vers le futur, et pourtant la ligne Masiero anticipe en quelque sorte les formes de design qui sont ancrées dans le passé, mais qui regardent vers le nouveau. C'est une recherche de lignes nouvelles qui s'entrelacent, se superposent, dépassent le style le plus classique, sans toutefois jamais nier la continuité et ses racines. Des lustres dans un style « minimaliste » avec tout ce que ce terme signifie à partir des années soixante. Minimaliste signifie la sobriété de la forme qui ne veut dans son essentiel que montrer ce qu'elle est. Mais minimaliste est aussi tout ce que l'objet nous communique inévitablement et tout ce que nous voulons voir dans cet objet. Minimaliste semble vouloir dire négation de l'art et que presque tous ceux d'entre nous peuvent, avec un peu d'imagination, l'égaliser, si ce n'est que les "codes" du minimalisme sont tellement complexes et particuliers – par exemple par rapport au langage purement figuratif – que seules des heures de larmes et de sang peuvent en dériver. Et les « codes » ne sont pas compréhensibles en un seul coup d'œil, mais avec l'intuition de l'esprit, de catégories conceptuelles : "des choses que vous humains ne pourriez vous imaginer." Des choses que ceux qui ont pénétré les secrets du futur ne peuvent pas communiquer parce que le futur ne nous appartient pas. Cependant, la ligne Masiero réussit à communiquer parce qu'elle lie et soude le futur avec le passé et le passé est à l'intérieur de nous. C'est la lampe au laser dans le cabinet marron du Dr. Freud dans la Vienne du début du XIXe siècle.

DE

**ALLES IST DA.  
DIE VERGANGENHEIT, DIE ZUKUNFT, DAS ERFORSCHEN DES  
GEISTES, UM DAS ANS LICHT ZU BRINGEN, WAS IN UNS  
STECKT, WAS WIR ABER NIE ZUVOR GESEHEN HABEN—**

Es ist nicht einfach, nach vorne, in die Zukunft zu blicken. Und doch nimmt die Linie Masiero irgendwie Designformen vorweg, die in der Vergangenheit wurzeln, gleichzeitig aber auf das Neue ausgerichtet sind. Eine Suche nach neuen Linien, die sich verflechten, überlagern und über den rein klassischen Stil hinaus gehen, ohne jedoch jemals die Kontinuität und ihre Wurzeln abzuleugnen. Lampen im "minimalistischen" Stil, mit all dem, was der Begriff seit den 60er Jahren bedeutet. Minimalistisch ist die Schlichtheit der Formen, die in ihrer nüchternen Art nur das zeigen will, was sie ist. Doch minimalistisch ist auch all das, was uns der Gegenstand unweigerlich mitteilt, und all das, was wir in diesem Gegenstand sehen wollen. Minimalistisch scheint die Negation der Kunst, und es sieht so aus, als ob wir es ihr fast alle, mit etwas Fantasie, gleich tun können, wenn sich die "Regeln" des Minimalismus nicht – im Vergleich zur rein figurativen Sprache – durch eine derartige Komplexität und Besonderheit auszeichnen würden, dass sie nur durch lange Stunden des Tränen- und Blutvergießens geschaffen werden können. Und die "Regeln" erfasst man nicht auf einen Blick, sondern dank der Intuition des Verstandes, der begrifflichen Kategorien: "Dinge, die Ihr Menschen niemals glauben würdet". Dinge, die uns von denjenigen, die glauben, die Geheimnisse der Zukunft durchdrungen zu haben, nicht übermittelt werden können, weil uns die Zukunft nicht gehört. Doch der Linie Masiero gelingt es, zu kommunizieren, weil sie die Zukunft fest mit der Vergangenheit verbindet, und weil die Vergangenheit in ihr steckt. Sie ist die Laserleuchte im braunen Wohnzimmer von Dr. Freud in der Stadt Wien zu Anfang des 20. Jahrhunderts.

ESP

**Y HAY DE TODO.  
EL PASADO, EL FUTURO Y EL AHONDAR DENTRO DE LA  
MENTE PARA SACAR A LA LUZ LO QUE ESTÁ DENTRO DE  
NOSOTROS, PERO QUE NUNCA HEMOS VISTO—**

No es fácil mirar hacia adelante hacia el futuro y sin embargo la línea Masiero de algún modo anticipa formas de diseño que están ancladas en el pasado pero que miran hacia lo nuevo. Es una búsqueda de líneas nuevas que se entrelazan, se superponen, superan el estilo más clásico, pero sin negar nunca la continuidad y las propias raíces. Lámparas de estilo "minimalista" con todo lo que el término significa de los años 60 en adelante. Es minimalista la sobriedad de la forma que en su esencialidad sólo quiere mostrar lo que es. Pero también es minimalista todo lo que inevitablemente el objeto nos comunica y todo lo que nosotros queremos ver en el objeto. Parece minimalista la negación del arte y parece que para casi todos nosotros, con un poco de imaginación, sería posible igualar si no fuera porque los "códigos" del minimalismo tienen una complejidad y una particularidad tales – respecto por ejemplo al lenguaje puramente figurativo – que sólo horas de lágrimas y sangre pueden generar. Y los "códigos" no se captan a primera vista, sino con la intuición de la mente, de categorías conceptuales: "cosas que vosotros humanos no podríais imaginaros". Cosas que para quien ha ahondado en los secretos del futuro no puede comunicar porque el futuro no nos pertenece. Pero la línea Masiero logra comunicar porque enlaza y une el futuro con el pasado y el pasado está dentro. Es la lámpara de láser en el tinaco marrón del Dr. Freud en la Viena de principios del siglo XX.

**ECLETTICA**

# BOOL

Design by:  
Studio Stile Masiero

















Bool PL2



Bool PL3 P



# BOOL

Design by: Studio Stile Masiero

Struttura in metallo verniciato, pendagli in cristallo trasparente, illuminazione LED.

Painted metal frame, transparent cut crystal pendants, LED lighting.

Struktur aus lackiertem Metall, Behang aus transparentem Kristall, LED-Leuchtsystem.

Structure en metal verni, pampilles en cristal transparent, éclairage LED.



Estructura en metal barnizado, colgantes en cristal transparente, iluminación LED.



## WH-M



Bianco

Opaco

**BOOL S3 G**  



L 85 cm 33.46"  
L' 65 cm 25.59"  
H 20 cm 7.87"

UP LED : 18W  
tot 3000K - 2200 lm  
DOWN LED : 63W  
3000K - 7535 lm

**BOOL S3 P**  



L 60 cm 23.62"  
L' 45 cm 17.71"  
H 15 cm 5.9"

UP LED : 10W  
tot 3000K - 1200 lm  
DOWN LED : 34W  
3000K - 3790 lm

**BOOL PL3 G**  

L 85 cm 33.46"  
L' 65 cm 25.59"  
H 20 cm 7.87"

DOWN LED : 63W  
tot 3000K - 7535 lm

**BOOL PL3 P**  

L 60 cm 23.62"  
L' 45 cm 17.71"  
H 15 cm 5.9"

DOWN LED : 34W  
tot 3000K - 3790 lm

**BOOL PL2** CE

**L** 36 cm 14.17"  
**L'** 10 cm 3.93"  
**H** 11 cm 4.33"

LED 6W tot 3000K - 1708 lm

**BOOL SPOT** CE

**H** 5 cm 1.97"  
**Ø** 16 cm 4.72"

LED 3W tot 3000K - 854 lm

**BOOL A1** CE

**L** 16 cm 6.29"  
**H** 8 cm 3.15"  
**SP** 20 cm 7.87"

UP LED : 3W  
tot 3000K - 854 lm  
DOWN LED : 3W  
tot 3000K - 854 lm

**BOOL A2** CE

**L** 40 cm 15.75"  
**H** 11 cm 4.33"  
**SP** 21 cm 8.27"

UP LED : 7W  
tot 3000K - 850 lm  
DOWN LED : 6W  
tot 3000K - 1708 lm



# KIRK

Design by:  
Manuel Vivian





# KIRK

Design by: Manuel Vivian

Struttura in metallo verniciato, diffusore in vetro veneziano lavorato a mano, illuminazione LED.

Painted metal frame, hand made venetian glass diffuser, LED lighting.



Struktur aus lackiertem Metall, Licht Diffusoren aus handgemachtem Venezianischem Murano-Glas, LED-Leuchtsystem.

Structure en metal verni, diffuseurs en verre de Venise fait à main, éclairage LED.

Estructura en metal barnizado, difusor de cristal veneciano hecho a mano , iluminación LED.



**WH-M**  
Bianco  
Opaco

**KIRK A1**  

<b>H</b>	24 cm	9.44"
<b>Ø</b>	21 cm	8.27"
<b>SP</b>	24 cm	9.44"

LED 12W tot 3000K - 1400 lm

DIMMABLE

# PALM

Design by:  
mammini . candido





NEW YORK







Palm A W04



Palm A W05



Palm A W06



Palm A W07



Palm A F01



Palm A F02

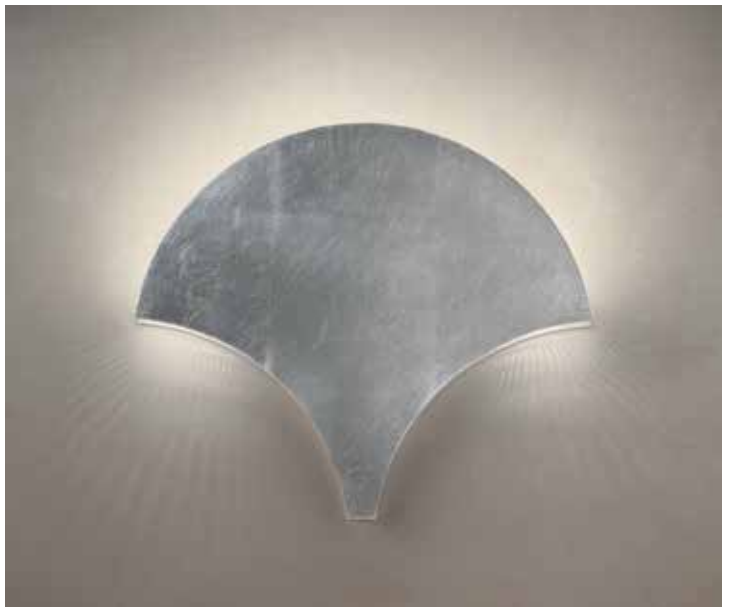





# PALM

Design by: mammini . candido

Struttura in metallo verniciato, rivestimento in diverse finiture, illuminazione LED.

Painted metal frame, different finishes cover, LED lighting.

Struktur aus lackiertem Metall, in verschiedenen Ausführungen erhältlich, LED-Leuchtsystem.

Structure en metal verni, différentes finitions disponibles, éclairage LED.

Estructura en metal barnizado, revestimiento en diferentes acabados, iluminación LED.



**F01**  
Foglia Oro



**F02**  
Foglia Argento

**W04**  
Pale Oak

**W05**  
Walnut

**W06**  
Grey Ayous

**W07**  
Black&Silver

**PALM A**  

<b>H</b>	34 cm	13.38"
<b>L</b>	40 cm	15.74"
<b>SP</b>	5 cm	1.96"

STRIP LED 13W 3000K - 1000 lm

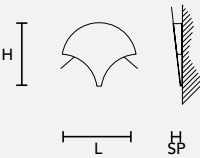

# MABELL

Design by:  
Manuel Vivian



Mabell S3 G



















# MABELL

Design by: Manuel Vivian

Struttura in poliuretano espanso, diffusore in metacrilato opaco con finitura cromata. Illuminazione LED

Frame made of expanded polyurethane foam, matt chromed finished methacrylate diffuser. LED lighting system.

Struktur aus Polyurethanschäumstoff, Lichtdiffusor aus matt verchromt gefärbtem Methacrylat. LED-Beleuchtung.

Structure en polyuréthane expansé, diffuseur en méthacrylate chrome mat. LED éclairage.

Estructura en poliuretano espanso, difusor en metacrilato opaco con acabado cromo. Iluminación LED



<b>WH-M</b> Bianco Opaco	<b>BK-M</b> Nero Opaco	<b>MOR-M</b> Arancio	<b>MGR-M</b> Verde	<b>MRE-M</b> Rosso Mattone	<b>MYE-M</b> Giallo	<b>MVI-M</b> Viola	<b>MTO-M</b> Tortora	<b>MBL-M</b> Blu
--------------------------------	------------------------------	-------------------------	-----------------------	----------------------------------	------------------------	-----------------------	-------------------------	---------------------

**MABELL S3 G** CE F

**H** 50 cm 19.68"  
**Ø** 85 cm 33.46"

**LED 3 LED 36 W**  
tot 3000 K – 4000 lm  
DIMMABLE

**MABELL S3 P** CE F

**H** 30 cm 11.81"  
**Ø** 50 cm 19.68"

**LED 3 LED 23W**  
tot 3000 K – 2790 lm  
DIMMABLE

**MABELL PL** CE F

**H** 20 cm 7.87"  
**Ø** 38 cm 14.96"

**LED 1 LED 17,5 W**  
3000 K – 2000 lm  
DIMMABLE

**MABELL SPOT** CE F

**H** 21,5 cm 8.46"  
**L** 15 cm 5.51"  
**SP** 14 cm 5.90"

**LED 1 LED 7,5 W**  
3000 K – 1000 lm  
DIMMABLE

**MABELL A2** CE F

**H** 21,5 cm 8.46"  
**L** 15 cm 5.51"  
**SP** 16,5 cm 5.90"

**LED 2 LED 15 W**  
tot 3000 K – 2000 lm  
DIMMABLE

**MABELL TL** CE F

**H** 21,5 cm 8.46"  
**L** 15 cm 5.51"  
**SP** 14 cm 5.90"

**LED 1 LED 5 W**  
3000 K – 500 lm  
DIMMABLE

# RIPPLE

Design by:  
CASTile design















# RIPPLE

Design by: CASTile design

Struttura in legno di rovere e metallo verniciato. Gocce in vetro con lavorazione a baloton sommerso. Illuminazione LED diretta ed indiretta.

Oak wood and painted metal frame. Glass drops made with Venetian glass technique 'baloton sommerso'. Direct and indirect LED lighting system.

Struktur aus Eichenholz und lackiertem Metall. Kristallglastropfen in 'Baloton Sommerso'-Technik hergestellt. Direkte und indirekte LED-Beleuchtung.

Structure en bois de chêne rouvre naturel et métal verni. Gouttes en verre réalisées selon la technique vénitienne 'baloton sommerso'. Éclairage direct et indirect avec LEDs.

Estructura en madera de roble y metal barnizado. Gotas en vidrio con elaboración a baloton sumergido. Iluminación LED directa e indirecta.



**W01**  
Natural Oak

**W02**  
White Oak

**W03**  
Wengé

**RIPPLE S** CE

<b>H</b>	44 cm	17.32"
<b>L</b>	120 cm	47.24"
<b>SP</b>	40 cm	15.74"

UP 3 LED : 30W  
tot 3000K - 3600 lm

DOWN 5 LED : 10W  
tot 3000K - 635 lm

DIMMABLE

**RIPPLE A3** CE

<b>H</b>	44 cm	17.32"
<b>L</b>	62 cm	24.40"
<b>SP</b>	9,5 cm	3.74"

UP 2 LED : 14W  
tot 3000K - 1480 lm

DOWN 3 LED : 6W  
tot 3000K - 380 lm

DIMMABLE

**RIPPLE A1** CE

<b>H</b>	44 cm	17.32"
<b>L</b>	32 cm	12.59"
<b>SP</b>	9,5 cm	3.74"

UP 1 LED : 7W  
3000K - 740 lm

DOWN 1 LED : 2W  
3000K - 130 lm

DIMMABLE

# VIRGO

Design by:  
Manuel Vivian

















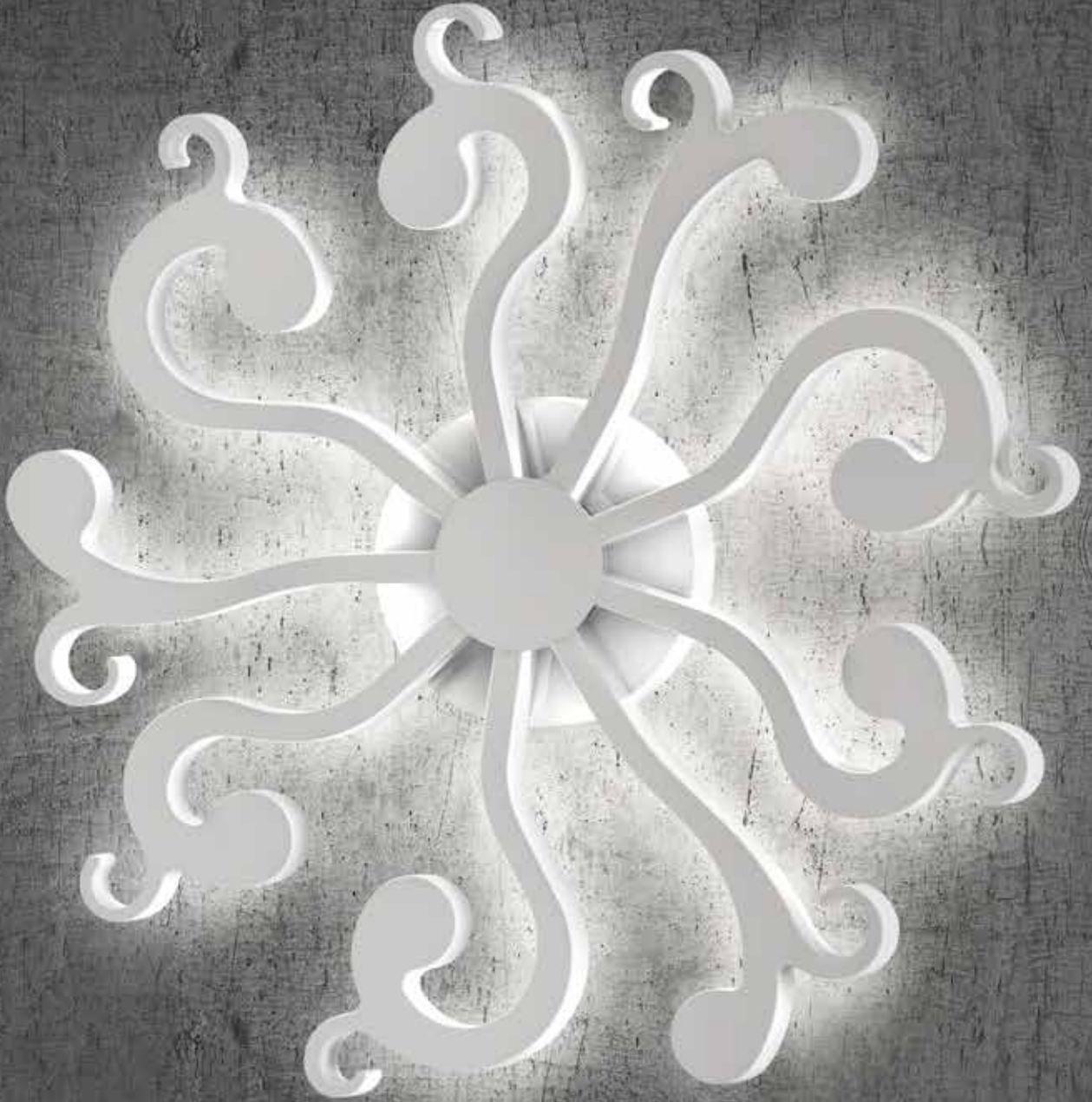

# VIRGO

Design by: Manuel Vivian

Struttura in poliuretano espanso e metallo verniciato. Illuminazione LED diretta e indiretta.

Frame made of expanded polyurethane foam and painted metal. Direct and indirect LED lighting system.

Struktur aus Polyurethanschaumstoff und lackiertem Metall. Direkte und indirekte LED-Beleuchtung.

Structure en polyuréthane expansé et en métal verni. Éclairage direct et indirect avec LEDs.

Estructura en poliuretano espanso y metal barnizado. Iluminación LED directa e indirecta.

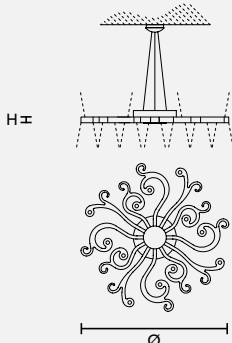

**VIRGO S100** CE 

**H** 9 cm 3.54"  
**Ø** 105 cm 41.33"

UP STRIP LED : 45W  
3000K - 3300 lm  
DOWN 12 LED : 23W  
tot 3000K - 3000 lm  
DIMMABLE

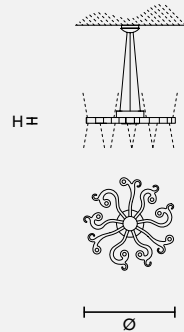

**VIRGO S70** CE 

**H** 9 cm 3.54"  
**Ø** 67 cm 26.37"

UP STRIP LED : 20W  
3000K - 1500 lm  
DOWN 9 LED : 18W  
tot 3000K - 2000 lm  
DIMMABLE

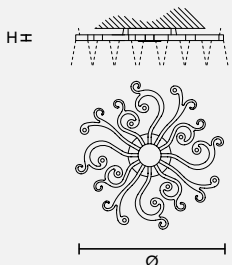

**VIRGO PL100** CE 

**H** 9 cm 3.54"  
**Ø** 105 cm 41.33"

UP STRIP LED : 45W  
3000K - 3300 lm  
DOWN 12 LED : 23W  
tot 3000K - 3000 lm  
DIMMABLE

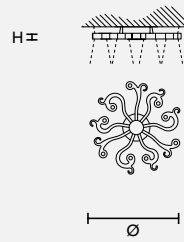

**VIRGO PL70** CE 

**H** 9 cm 3.54"  
**Ø** 67 cm 26.37"

UP STRIP LED : 20W  
3000K - 1500 lm  
DOWN 9 LED : 18W  
tot 3000K - 2000 lm  
DIMMABLE

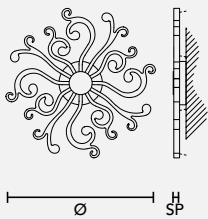

**VIRGO A100** CE 

**SP** 9 cm 3.54"  
**Ø** 105 cm 41.33"

**LED** STRIP led x 45W  
3000K - 3000 lm  
DIMMABLE

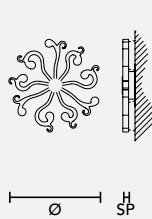

**VIRGO A70** CE 

**SP** 9 cm 3.54"  
**Ø** 67 cm 26.37"

**LED** STRIP led x 20W  
3000K - 1500 lm  
DIMMABLE











Tiepolo P



Tiepolo G

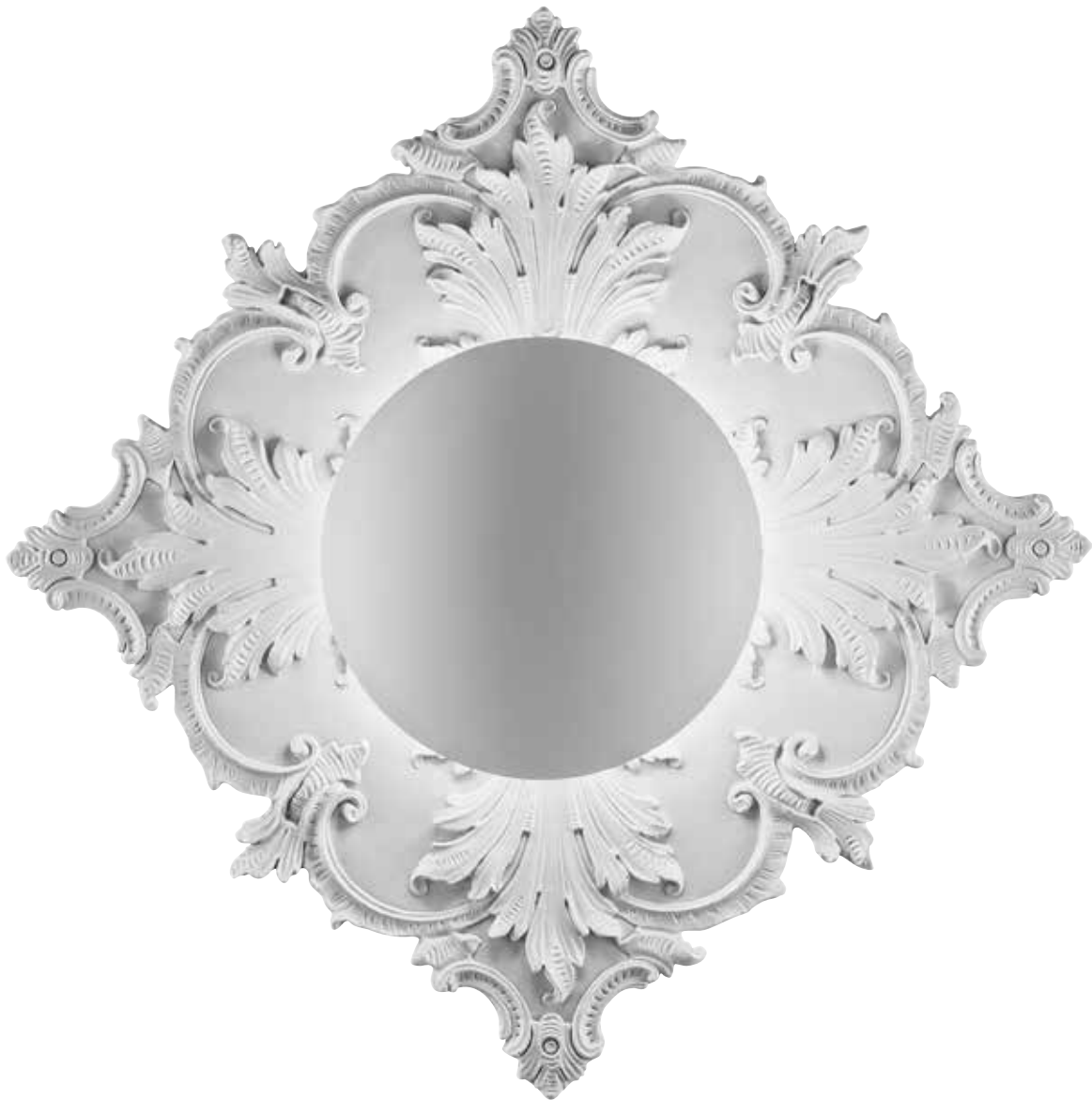

# TIEPOLO

Design by: Manuel Vivian

Struttura in resina e metallo verniciato. Illuminazione LED.

Resin and metal painted frame. LED lighting system.

Struktur aus Kunststoff und lackiertem Metall. LED-Beleuchtung.

Structure en résine et métal verni. LED éclairage.

Estructura en resina y metal barnizado. Iluminación LED.

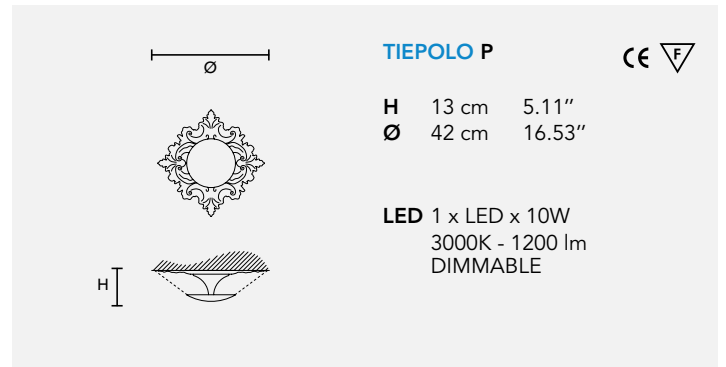
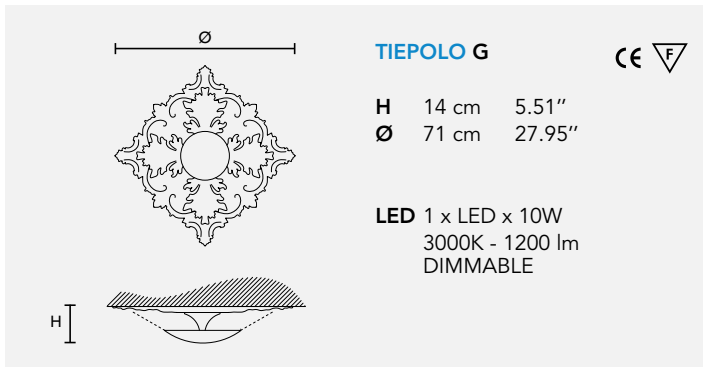

# EMPIRE

Design by:  
Manuel Vivian

Empire Particolare













# EMPIRE

Design by: Manuel Vivian

Struttura in metallo verniciato con dettagli cromati.  
Pendagli in cristallo.  
Illuminazione LED.

Painted metal frame with chrome plated details.  
Crystal pendants.  
LED lighting.

Lackierte Metallstruktur mit verchromten Details.  
Behang aus Kristall.  
LED-Beleuchtung.

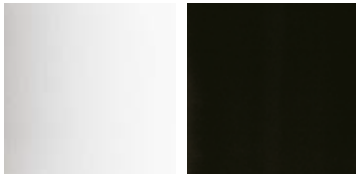

Structure en métal peint avec détails chromés.  
Pampilles en cristal.  
Éclairage LED.

Estructura de metal pintado con detalles cromados.  
Abalorios de cristal.  
Iluminación LED.





**WH-M**  
Bianco  
Opaco

**BK-M**  
Nero  
Opaco

**EMPIRE S90**  



H 90 cm 35.43"  
Ø 90 cm 35.43"

UP 12 LED : 42W  
tot 3000K - 4300 lm  
DOWN 1 LED : 17W  
3000K - 1600 lm  
DIMMABLE

**EMPIRE S60**  



H 60 cm 23.62"  
Ø 60 cm 23.62"

UP 8 LED : 28W  
tot 3000K - 2800 lm  
DOWN 1 LED : 17W  
3000K - 1600 lm  
DIMMABLE

**EMPIRE S45**  

H 48 cm 18.89"  
Ø 45 cm 17.71"

UP 8 LED : 21W  
tot 3000K - 2100 lm  
DOWN 3 LED : 8W  
tot 3000K - 800 lm  
DIMMABLE

**EMPIRE A**  

L 42 cm 16.53"  
H 42 cm 16.53"  
SP 14 cm 5.51"

UP 4 LED : 9W  
tot 3000K - 1000 lm  
DOWN 2 LED : 5W  
tot 3000K - 500 lm  
DIMMABLE

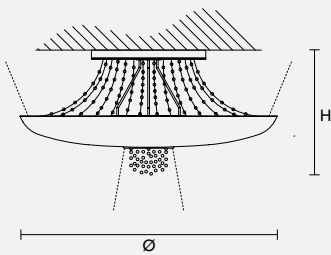

**EMPIRE PL90**



H 45 cm 17.71"  
 Ø 90 cm 35.43"

UP 12 LED : 42W  
 tot 3000K - 4300 lm  
 DOWN 1 LED : 17W  
 3000K - 1600 lm  
 DIMMABLE

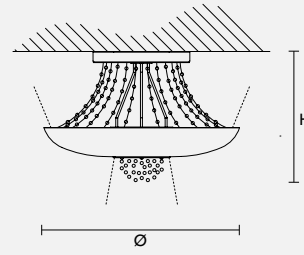

**EMPIRE PL60**



H 40 cm 15.74"  
 Ø 60 cm 23.62"

UP 8 LED : 28W  
 tot 3000K - 2800 lm  
 DOWN 1 LED : 17W  
 3000K - 1600 lm  
 DIMMABLE

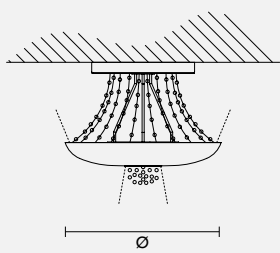

**EMPIRE PL45**



H 37 cm 14.56"  
 Ø 45 cm 17.71"

UP 8 LED : 21W  
 tot 3000K - 2100 lm  
 DOWN 3 LED : 8W  
 tot 3000K - 800 lm  
 DIMMABLE

**BLINK**

Design by:  
Manuel Vivian













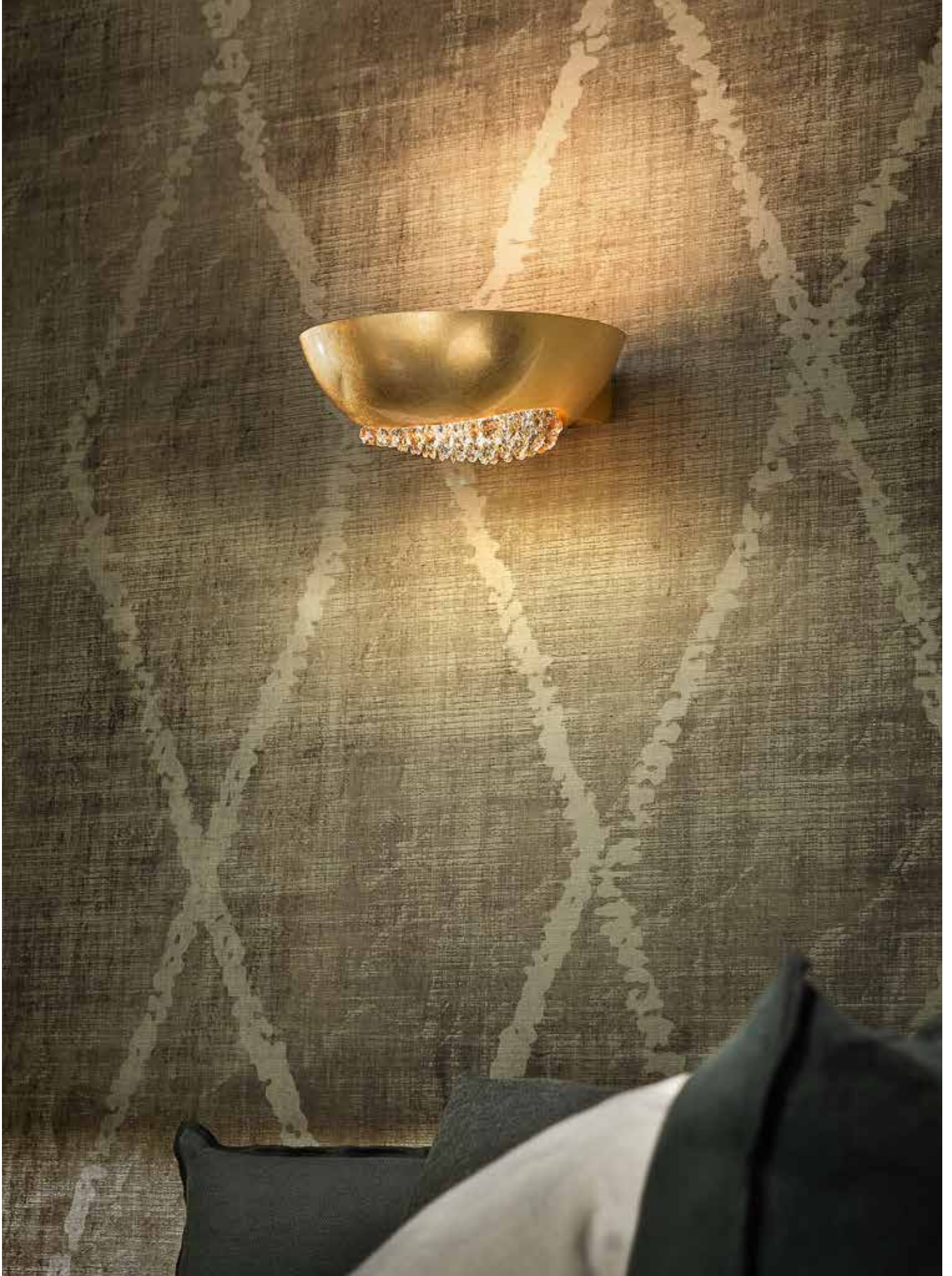

# BLINK

Design by: Manuel Vivian

Struttura in alluminio con finitura in foglia oro o verniciata in colore bianco opaco.

Pendagli in Swarovski® Elements Crystal Blue AB.

Aluminium frame with gold leaf or matt white painted finish.

Swarovski® Elements Crystal Blue AB pendants.

Aluminiumstruktur mit Oberfläche aus Blattgold oder lackiert in der Farbe Weiß Matt.

Behang aus Swarovski® Elements Crystal Blue AB.

Structure en aluminium dorée à la feuille d'or ou peinte en blanc opaque. Pampilles en Swarovski® Elements Crystal Blue AB.

Estructura de aluminio con acabado en pan de oro o pintada de color blanco mate.

Abalorios de Swarovski® Elements Crystal Blue AB.





**WH-M**  
Bianco  
Opaco

**F-01**  
Foglia Oro

**BLINK PL8 90** 

**H** 15 cm 5.90"  
**Ø** 90 cm 35.43"

 8 x E14 x 40W max

**USA:**  
 8 x E12 x 40 W max  
*not included*

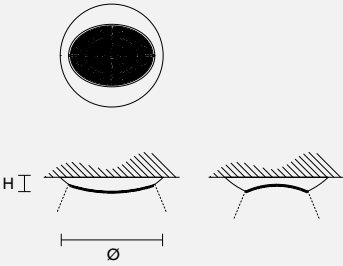



**BLINK PL6 60** 

**H** 14 cm 5.51"  
**Ø** 60 cm 23.62"

 6 x E14 x 40W max

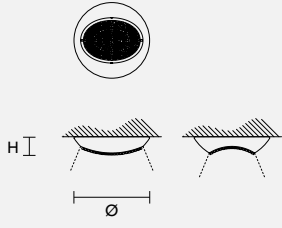
**USA:**  
 6 x E12 x 40 W max  
*not included*



**BLINK PL4 42** 

**H** 12 cm 4.72"  
**Ø** 42 cm 16.53"

 4 x E14 x 40W max

**USA:**  
 4 x E12 x 40 W max  
*not included*

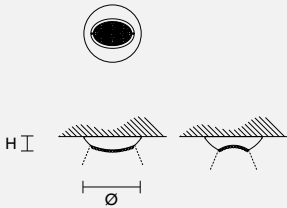

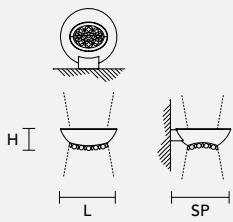

**BLINK A1 P**



**L** 18 cm 7.08"  
**H** 7 cm 2.75"  
**SP** 19 cm 7.48"

3 x R7s 78mm x 48W max

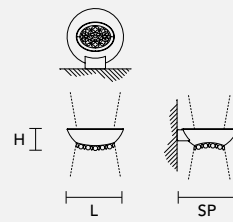

**BLINK A1 G**



**L** 23 cm 9.05"  
**H** 9 cm 3.54"  
**SP** 25 cm 9.84"

1 x R7s 78mm x 80W max

# DROPOP

Design by:  
Cambi, Scatena, Turini















Dropop Dettaglio



# DROPOP

Design by: Cambia, Scatena, Turini

Installazione modulare, disponibile in 3 varianti: sospensione, plafoniera o decoro senza lampadina. Struttura in legno tornito, diffusore in metallo, illuminazione LED.

Modular Installation, available in 3 versions: suspension, ceiling or decoration without light. Turned wood frame, metal diffuser, LED bulb.

Modulare Installation, erhältlich in 3 Versionen: Aufhängung, Deckenbefestigung oder Dekoration ohne Lampen. Abgerundeter Holzrahmen, Metall-Diffusor, LED Lampen.

Installation modulaire, disponible en 3 versions: suspension, plafond ou décoration sans ampoules. Structure en bois arrondie, métal diffuseur, ampoules LED.

Instalacion modular, disponible en 3 variantes: colgante, plafon o solo decoracion sin lampara. Estructura en madera moldada, difusor en metal, iluminacion con LED.

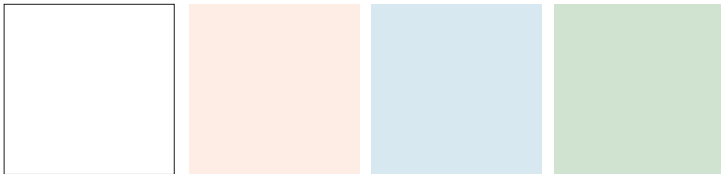



**WH-S**  
bianco  
lucido

**PKC-S**  
rosa confetto  
lucido

**LBZ-S**  
azzurro zucchero  
lucido

**GRP-S**  
verde pallido  
lucido



**DROPOP S75**   

H 75 cm 29.52"  
Ø 16 cm 6.29"

**LED VERSION**  
1xG53 LEDx15 W 3000K - 800 lm

**HALOGEN VERSION**  
1xG53 HALOGENx50 W

**USA:**  
1 x E12 x 40 W max  
not included



**DROPOP S60**   

H 60 cm 23.62"  
Ø 16 cm 6.29"

**LED VERSION**  
1xG53 LEDx15 W 3000K - 800 lm

**HALOGEN VERSION**  
1xG53 HALOGENx50 W

**USA:**  
1 x E12 x 40 W max  
not included



**DROPOP S55**   

H 55 cm 21.65"  
Ø 16 cm 6.29"

**LED VERSION**  
1xG53 LEDx15 W 3000K - 800 lm

**HALOGEN VERSION**  
1xG53 HALOGENx50 W

**USA:**  
1 x E12 x 40 W max  
not included



**DROPOP S50**   

H 50 cm 19.68"  
Ø 16 cm 6.29"

**LED VERSION**  
1xG53 LEDx15 W 3000K - 800 lm

**HALOGEN VERSION**  
1xG53 HALOGENx50 W

**USA:**  
1 x E12 x 40 W max  
not included



**DROPOP S45**   

H 45 cm 17.71"  
Ø 16 cm 6.29"

**LED VERSION**  
1xG53 LEDx15 W 3000K - 800 lm

**HALOGEN VERSION**  
1xG53 HALOGENx50 W

**USA:**  
1 x E12 x 40 W max  
not included

**DROPOP S15**   

H 15 cm 5.90"  
Ø 16 cm 6.29"

**LED VERSION**  
1xG53 LEDx15 W 3000K - 800 lm

**HALOGEN VERSION**  
1xG53 HALOGENx50 W

**USA:**  
1 x E12 x 40 W max  
not included

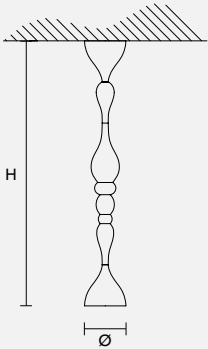

**DROPOP PL90** CE F UL

**H** 90 cm 35.43"  
**Ø** 16 cm 6.29"

**LED VERSION**  
 1xG53 LEDx15 W 3000K - 800 lm

**HALOGEN VERSION**  
 1xG53 HALOGENx50 W

**USA:**  
 1 x E12 x 40 W max  
*not included*

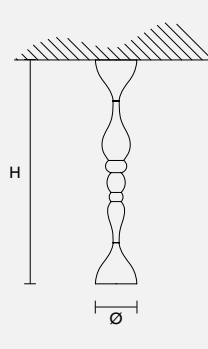

**DROPOP PL75** CE F UL

**H** 75 cm 29.52"  
**Ø** 16 cm 6.29"

**LED VERSION**  
 1xG53 LEDx15 W 3000K - 800 lm

**HALOGEN VERSION**  
 1xG53 HALOGENx50 W

**USA:**  
 1 x E12 x 40 W max  
*not included*

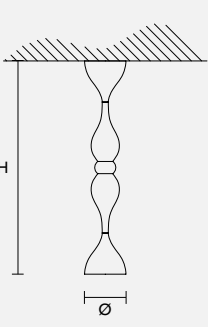

**DROPOP PL70** CE F UL

**H** 70 cm 27.55"  
**Ø** 16 cm 6.29"

**LED VERSION**  
 1xG53 LEDx15 W 3000K - 800 lm

**HALOGEN VERSION**  
 1xG53 HALOGENx50 W

**USA:**  
 1 x E12 x 40 W max  
*not included*

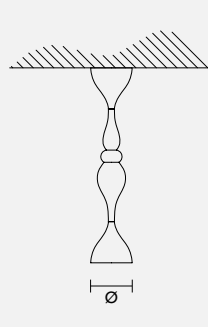

**DROPOP PL65** CE F UL

**H** 65 cm 25.59"  
**Ø** 16 cm 6.29"

**LED VERSION**  
 1xG53 LEDx15 W 3000K - 800 lm

**HALOGEN VERSION**  
 1xG53 HALOGENx50 W

**USA:**  
 1 x E12 x 40 W max  
*not included*

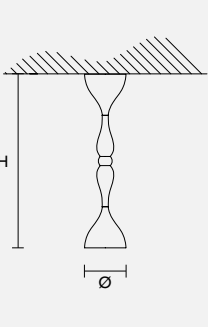

**DROPOP PL60** CE F UL

**H** 60 cm 23.62"  
**Ø** 16 cm 6.29"

**LED VERSION**  
 1xG53 LEDx15 W 3000K - 800 lm

**HALOGEN VERSION**  
 1xG53 HALOGENx50 W

**USA:**  
 1 x E12 x 40 W max  
*not included*

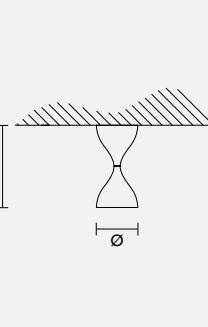

**DROPOP PL25** CE F UL

**H** 25 cm 9.84"  
**Ø** 16 cm 6.29"

**LED VERSION**  
 1xG53 LEDx15 W 3000K - 800 lm

**HALOGEN VERSION**  
 1xG53 HALOGENx50 W

**USA:**  
 1 x E12 x 40 W max  
*not included*

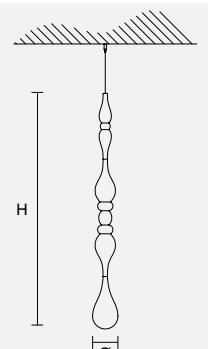

**DROPOP B85** CE F

**H** 85 cm 33.49"  
**Ø** 9 cm 3.54"

Nessuna luce / No light

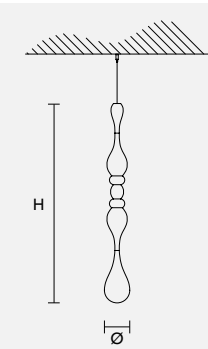

**DROPOP B70** CE F

**H** 70 cm 27.55"  
**Ø** 9 cm 3.54"

Nessuna luce / No light



**DROPOP B50** CE F

**H** 50 cm 19.68"  
**Ø** 9 cm 3.54"

Nessuna luce / No light

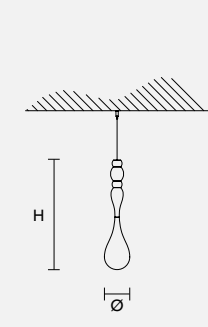

**DROPOP B40** CE F

**H** 40 cm 15.74"  
**Ø** 9 cm 3.54"

Nessuna luce / No light



# LIBE

Design by:  
Gianpaolo Rampolla & Andrea Liguori











Libe A55





Libe TL









# LIBE

Design by: Gianpaolo Rampolla & Andrea Liguori

Lampada LED in legno di Rovere naturale. La diffusione della luce è amplificata da losanghe in cristallo opaco. Base in metallo cromato.

LED lamp in natural oak wood. The diffusion of light is amplified by opaque crystal lozenges. Chromed metal base.

LED-Lampe in Eichenholz natur. Der Licht-Diffusor wird durch lange opak Kristalle verstärkt. Die Base ist aus verchromtem Metall.

Lampe LED en bois rouvre naturel. La diffusion de la lumière est amplifiée par des prismes en cristal opaque. Base en métal chromé.

Lampada de LED en roble natural. La difusion de la luz està amplificada por corte en rectángulos en cristal satinado. Base en metal cromado.



**W01**  
Natural Oak

**W02**  
White Oak

**W03**  
Wengé

**LIBE S100** CE F UL

<b>H</b>	20 cm	7.87"
<b>L</b>	100 cm	39.37"
<b>SP</b>	16 cm	6.29"

**LED x 52W 3000K - 2800 lm**

**LIBE S160** CE F UL

<b>H</b>	30 cm	11.81"
<b>L</b>	160 cm	62.99"
<b>SP</b>	16 cm	6.29"

**LED x 90W 3000K - 4850 lm**

**LIBE ROUND S90** CE F UL

<b>H</b>	8.5 cm	3.34"
<b>Ø</b>	90 cm	35.43"

**LED x 74W 3000K - 4000 lm**

**LIBE ROUND S60** CE F UL

<b>H</b>	8.5 cm	3.34"
<b>Ø</b>	60 cm	23.62"

**LED x 48W 3000K - 2600 lm**

**LIBE ELLIPSE S120** CE F UL

<b>H</b>	8.5 cm	3.34"
<b>L</b>	120 cm	47.24"
<b>SP</b>	40 cm	15.74"

**STRIP LED 70W 3000K - 5600 lm**

**LIBE ELLIPSE S90** CE F UL

<b>H</b>	8.5 cm	3.34"
<b>L</b>	90 cm	35.43"
<b>SP</b>	30 cm	11.81"

**STRIP LED 52W 3000K - 4100 lm**

**LIBE A55** CE

**H** 8.5 cm 3.34"  
**L** 55 cm 21.65"  
**SP** 8 cm 3.14"

**LED x 6W 3000K - 325 lm**

**LIBE TL** CE

**H** 40 cm 15.74"  
**L** 40 cm 15.74"  
**SP** 20 cm 7.87"

**LED x 15W 3000K - 800 lm**

**LIBE STL** CE

**H** 180 cm 70.86"  
**L** 156 cm 61.41"  
**SP** 36 cm 11.00"

**LED x 23W 3000K - 1250 lm**

**LIBE ROUND TL40** CE

**H** 43 cm 16.93"  
**L** 40 cm 15.74"  
**SP** 30 cm 11.81"

**LED x 30 W 3000K - 1600 lm**

# FLASHWOOD

Design by:  
Studio Eggs

















# FLASHWOOD

Design by: Studio Eggs

Lampada a LED con bracci in legno di rovere naturale; diffusori in borosilicato.

LED lamp with arms made in natural oak; borosilicate diffuser.

LED-Leuchter mit Armen aus Eichenholz natur. Diffusoren aus borosilicate.

Lampe à Leds avec des bras en bois de chêne rouvre naturel; diffuseurs en borosilicate.

Lámpara de LED con brazos de madera de roble natural; difusores de borosilicato.

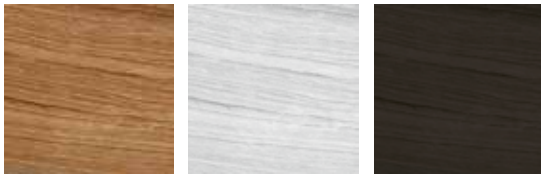



**W01**  
Natural Oak

**W02**  
White Oak

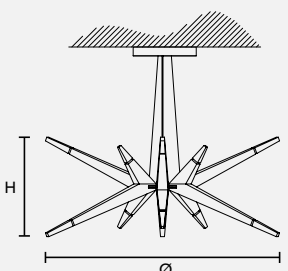
**W03**  
Wengé





**FLASHWOOD S12 140**  

**H** 55 cm 21.65"  
**Ø** 140 cm 55.12" 

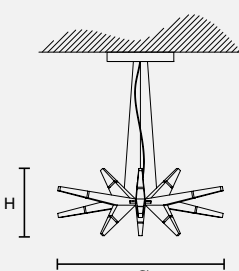
**LED** 12 x LED x 6W tot 3000K - 1000 lm DIMMABLE  
WHITE VERSION  
12 x LED x 6W tot 4000K - 1500 lm DIMMABLE





**FLASHWOOD S12 90**  

**H** 35 cm 13.77"  
**Ø** 90 cm 35.43" 

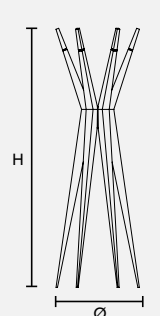
**LED** 12 x LED x 6W tot 3000K - 1000 lm DIMMABLE  
WHITE VERSION  
12 x LED x 6W tot 4000K - 1500 lm DIMMABLE



**FLASHWOOD STL6+6**  

**H** 180 cm 70.87"  
**Ø** 62 cm 24.41"

**LED** 12 x LED x 6W tot 3000K - 1000 lm DIMMABLE  
WHITE VERSION  
12 x LED x 6W tot 4000K - 1500 lm DIMMABLE

# BLOSSOMY

Design by:  
Fly Design Studio













# BLOSSOMY

Design by: Cambia, Scatena, Turini

Lampada a luce indiretta con petali in alluminio verniciato; fonte luminosa nascosta nella coppa in metallo verniciato.



Indirect light lamp with painted aluminium petals; luminous source hidden in the painted metal cup. Lampe mit indirektem

Licht, mit Blütenblättern aus lackiertem Aluminium; die Lichtquelle ist in der Schale aus lackiertem Metall verborgen.

Lampe à lumière indirecte avec des pétales en aluminium verni ; source lumineuse cachée dans la coupe en métal verni.

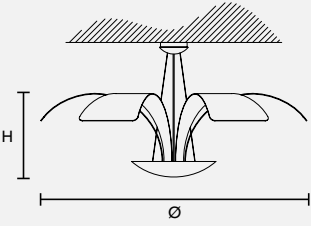
Lámpara de luz indirecta con pétalos de aluminio barnizado; fuente luminosa escondida en la tulipa de metal barnizado.







**BLOSSOMY S120**   

**H** 40 cm 15.75"  
**Ø** 120 cm 47.24"

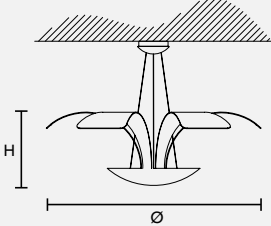
**LED** 4 LED 20W  
tot 3000 K – 3000 lm  
DIMMABLE

**USA:**  
 4 x E12 x 40 W max  
not included







**BLOSSOMY S90**   

**H** 30 cm 11.81"  
**Ø** 90 cm 35.43"

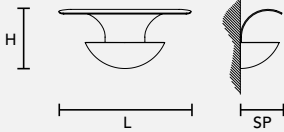
**LED** 4 LED 20W  
tot 3000 K – 3000 lm  
DIMMABLE

**USA:**  
 4 x E12 x 40 W max  
not included



**BLOSSOMY A1**   

**H** 16 cm 6.29"  
**L** 38 cm 14.96"  
**SP** 12 cm 4.72"

**LED** 1 LED 5W 3000 K – 740 lm  
DIMMABLE

**USA:**  
 1 x E12 x 40 W max  
not included

# BOTERO

Design by:  
Manuel Vivian











Botero A3







Botero S5+5 RED



Botero S5+5 BLACK

Botero TL2 BLACK



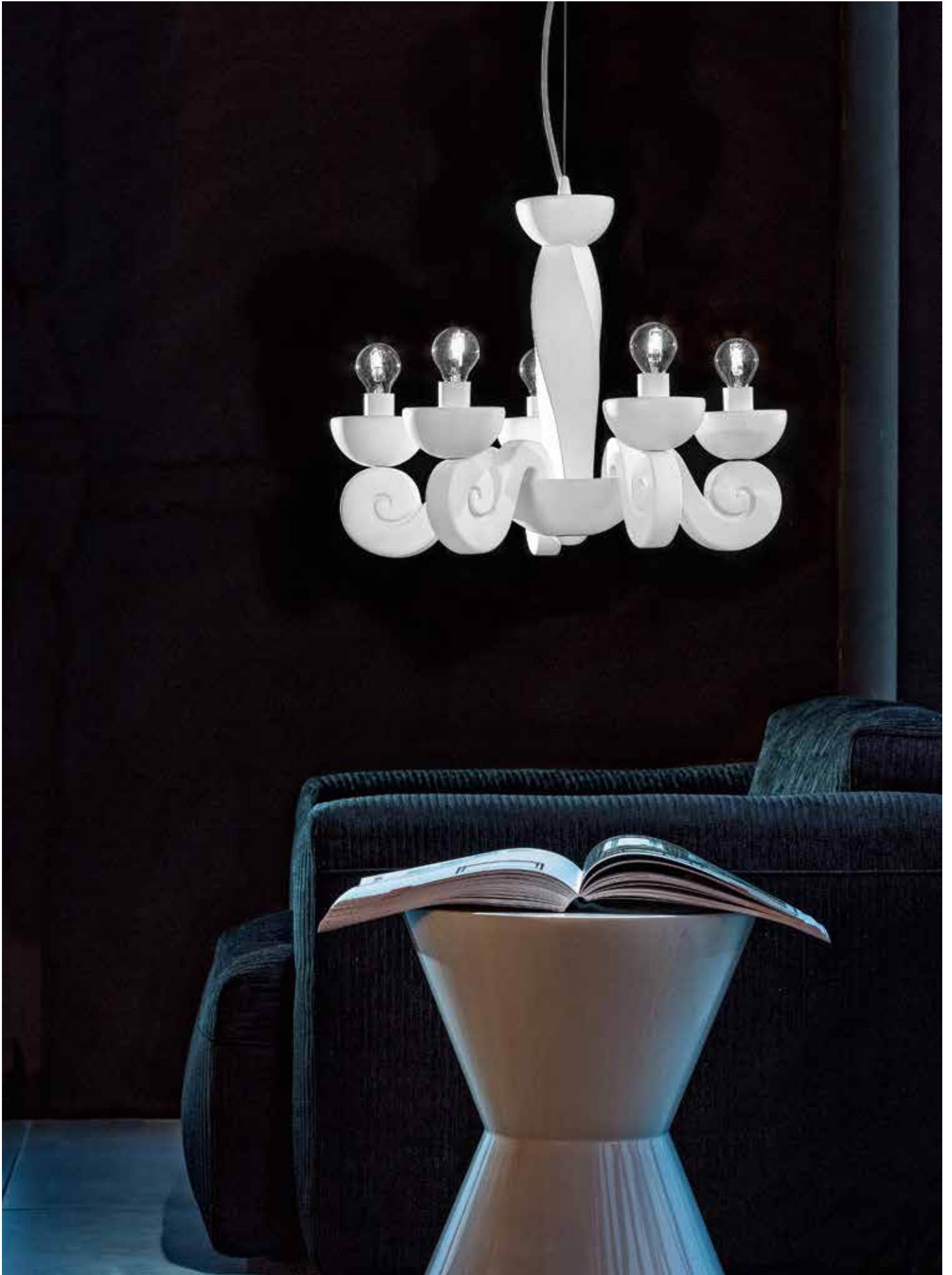

# BOTERO

Design by Manuel Vivian

Bracci e coppe in poliuretano espanso con lampadina a vista; struttura portante in metallo verniciato.

Arms and cups made of polyurethane foam with an exposed bulb; supporting frame made in painted metal.

Arme und Schalen aus Polyurethanschäumstoff mit sichtbarer Glühbirne; Tragstruktur aus lackiertem Metall.

Bras et coupes en polyuréthane expansé avec ampoule visible ; structure portante en métal verni.

Brazos y tulipas de poliuretano expandido con bombilla a la vista; estructura portante de metal barnizado.





**WH-M**  
bianco opaco

**RED-M**  
rosso opaco

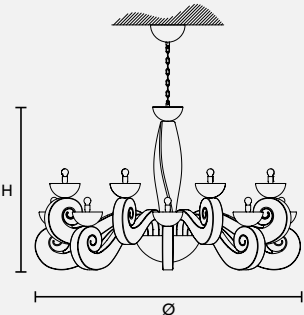
**BK-M**  
nero opaco







**BOTERO S8+8 230**   

H 140 cm 55.11"  
Ø 230 cm 90.55"

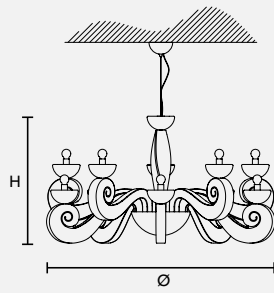
● 16 x E27 x 100W max

**USA:**  
● 16 x E26 x 60 W max  
*not included*







**BOTERO S5+5**   

H 65 cm 25.59"  
Ø 120 cm 47.24"

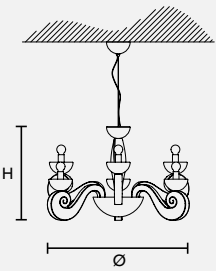
● 10 x E14 x 60W max

**USA:**  
● 10 x E12 x 40 W max  
*not included*







**BOTERO S3+3**   

H 50 cm 19.69"  
Ø 85 cm 33.46"

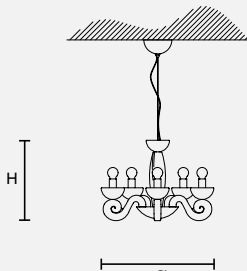
● 6 x E14 x 60W max

**USA:**  
● 6 x E12 x 40 W max  
*not included*



**BOTERO S5**   

H 35 cm 13.77"  
Ø 46 cm 18.11"

● 5 x E14 x 60W max

**USA:**  
● 5 x E12 x 40 W max  
*not included*

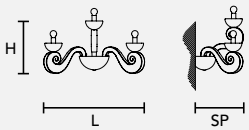

**BOTERO A3**



**H** 30 cm 11.81"  
**L** 40 cm 15.74"  
**SP** 23 cm 9.05"

● 3 x E14 x 60W max

**USA:**  
 ● 3 x E12 x 40 W max  
*not included*

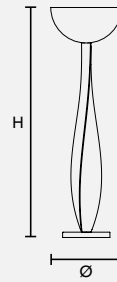

**BOTERO STL3**



**H** 195 cm 76.77"  
**Ø** 60 cm 23.62"

● 3 x G53 x 50W max

+

**LED** 4 x LED x 1W (included)

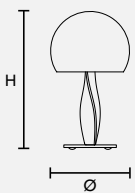

**BOTERO TL2**



**H** 55 cm 21.65"  
**Ø** 30 cm 11.81"

● 2 x E14 x 60W max

**USA:**  
 ● 2 x E12 x 40 W max  
*not included*

# ANIMA

Design by:  
Manuel Vivian



Anima PL6











Anima PL6 RUBINO



Anima PL6





# ANIMA

Design by: Manuel Vivian

Montatura metallica e  
goccia sospesa di cristallo,  
soffiato e lavorato a mano.

Metal mount and hand  
worked and blown hanging  
crystal drop.

Metallfassung  
mit hängendem  
Kristallglastropfen, geblasen  
und von Hand gearbeitet.

Monture métallique et  
pampille suspendue en  
cristal soufflé faite à la  
main.

Montura metálica y  
gota colgante de cristal,  
soplado y elaborado a  
mano.

## GLASS FINISHES



**ARG**  
Argento

**AZZ**  
Acquamarina

**RUB**  
Rubino

## FRAME FINISHES



**WH-M**  
Bianco Opaco

**G08**  
Nickel Nero

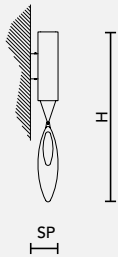

### ANIMA A2



**H** 60 cm 23.70"  
**Ø** 10 cm 4.00"  
**SP** 11 cm 4.40"

2 x GU10 x 35W max

#### USA:

2 x E12 x 40 W max  
not included

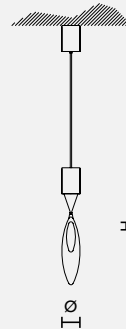

### ANIMA S1



**H** 40 cm 15.80"  
**Ø** 10 cm 4.00"

1 x GU10 x 35W max

#### USA:

1 x E12 x 40 W max  
not included

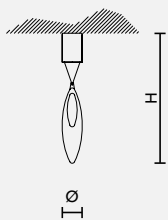

### ANIMA PL1



**H** 40 cm 15.80"  
**Ø** 10 cm 4.00"

1 x GU10 x 35W max

#### USA:

1 x E12 x 40 W max  
not included

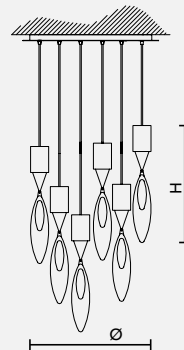

### ANIMA PL6



**H** 105 cm 41.33"  
**Ø** 60 cm 23.62"

6 x GU10 x 35W max

#### USA:

6 x E12 x 40 W max  
not included

# SASSO

Design by:  
Manuel Vivian

















# SASSO

Design by: Manuel Vivian

Diffusori in vetro soffiato  
montatura metallica  
verniciata a polvere in  
bianco, diffusore in vetro  
triplex di colore bianco.

Blown glass lights, white,  
dust-enamelled metal  
mount, shade in white  
triplex glass.

Diffusoren aus geblasenem  
Glas, Metallfassung mit  
weißer Pulverlackierung,  
Diffusor aus weißem  
Triplexglas.

Diffuseurs en verre soufflé,  
monture de métal vernie  
à poudre couleur blanche,  
diffuseur en verre triplex  
blanc.

Difusores de vidrio soplado  
montura metálica pintada  
de polvo blanco,  
difusor de vidrio triplex  
de color blanco.

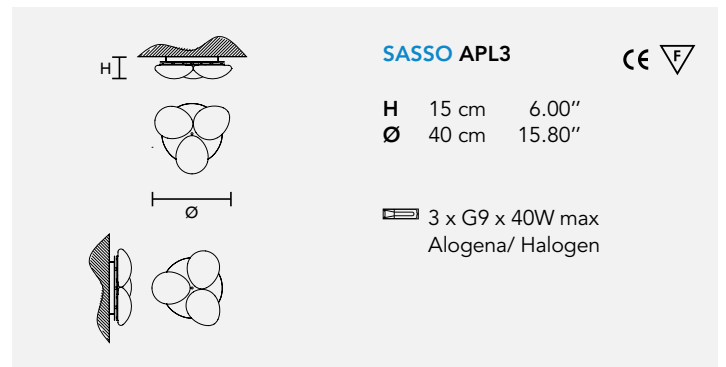
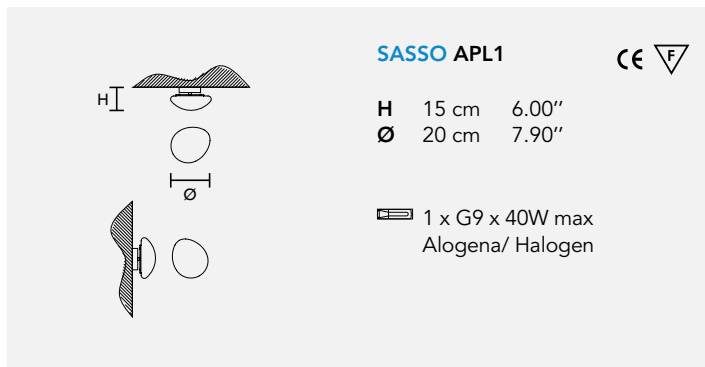

# EVA

Design by:  
Fly Design Studio

Eva TL3+1G



















Eva TL1M    Eva A1M



Eva A3





# EVA

Design by: Fly Design Studio

Lampada con struttura in resina e poliuretano laccati, paralumi in alluminio verniciato.

Lamp with lacquered resin and polyurethane frame, lamp shades from lacquered aluminium.

Lampe mit lackierter resin und polyurethanstruktur, Lampenschirme aus lackiertem Aluminium.

Lampe avec structure en resin et polyurethane laqué, abat-jour en aluminium verni.

Lámpara con estructura de resina y poliuretano lacado, pantallas de aluminio barnizado.



**F-02**  
Foglia Argento  
for Eva STL3+1  
only lampshade

**F-01**  
Foglia Oro  
for Eva STL3+1  
only lampshade

**WH-M**  
Bianco  
Opaco

**OR-S**  
Arancio  
Lucido

**PR-S**  
Magenta  
Lucido

**BK-S**  
Nero  
Lucido

**EVA S20+10** CE F UL

H 200 cm 78.80"  
Ø 280 cm 110.50"

● 30 x E14 x 60W max  
**USA:**  
● 30 x E12 x 40 W max  
not included

**EVA S10** CE F UL

H 75 cm 29.60"  
Ø 110 cm 43.40"

● 10 x E14 x 60W max  
**USA:**  
● 10 x E12 x 40 W max  
not included

**EVA S8** CE F UL

H 75 cm 29.60"  
Ø 90 cm 35.50"

● 8 x E14 x 60W max  
**USA:**  
● 8 x E12 x 40 W max  
not included

**EVA S5** CE F UL

H 60 cm 23.65"  
Ø 70 cm 27.60"

● 5 x E14 x 60W max  
**USA:**  
● 5 x E12 x 40 W max  
not included

**EVA S3+1** CE F UL

H 75 cm 29.60"  
Ø 50 cm 19.70"

● 3 x E27 x 100W max  
+  
● 1 x R7S x 150W max  
**USA:**  
● 3 x E26 x 60 W max  
+  
● 1 x E12 x 40 W max  
not included

**EVA A3** CE F UL

H 70 cm 27.60"  
L 40 cm 15.80"  
SP 20 cm 7.90"

● 3 x E27 x 100W max  
**USA:**  
● 3 x E26 x 60 W max  
not included

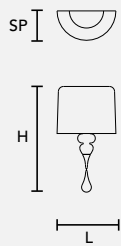

### EVA A1 M



**H** 54 cm 21.30"  
**L** 30 cm 11.90"  
**SP** 15 cm 6.00"

1 x E27 x 100W max

#### USA:

1 x E26 x 60 W max  
*not included*

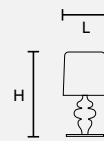

### EVA TL1 P



**H** 28 cm 11.10"  
**Ø** 14 cm 5.60"

1 x E14 x 60W max

#### USA:

1 x E12 x 40 W max  
*not included*

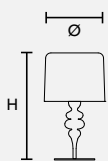

### EVA TL1 M



**H** 53 cm 21.00"  
**Ø** 30 cm 11.90"

1 x E27 x 100W max

#### USA:

1 x E26 x 60 W max  
*not included*

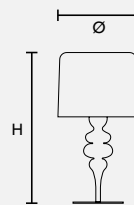

### EVA TL3+1G



**H** 75 cm 29.60"  
**Ø** 40 cm 15.80"

3 x E27 x 100W max  
 +  
 1 x R7S x 150W max

#### USA:

3 x E26 x 60 W max  
 +  
 1 x E12 x 40 W max  
*not included*

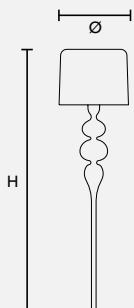

### EVA STL3+1



**H** 190 cm 74.90"  
**Ø** 50 cm 19.70"

3 x E27 x 100W max  
 +  
 1 x R7S x 150W max

#### USA:

3 x E26 x 60 W max  
 +  
 1 x E12 x 40 W max  
*not included*

ARTÈ

Design by:  
Manuel Vivian

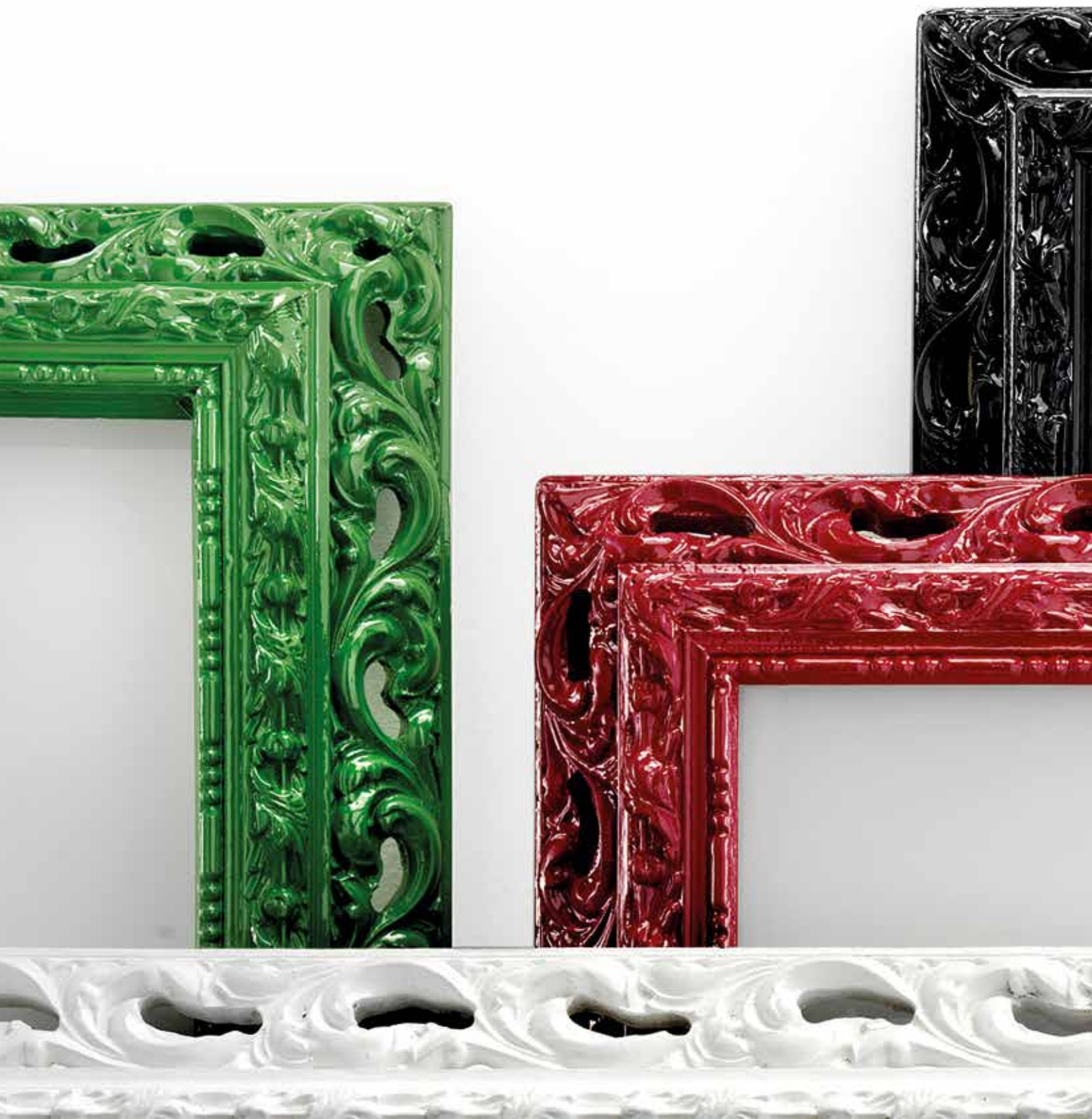





Artè S4 RC



Artè Linear S1



Artè A1 70



Artè A1 45







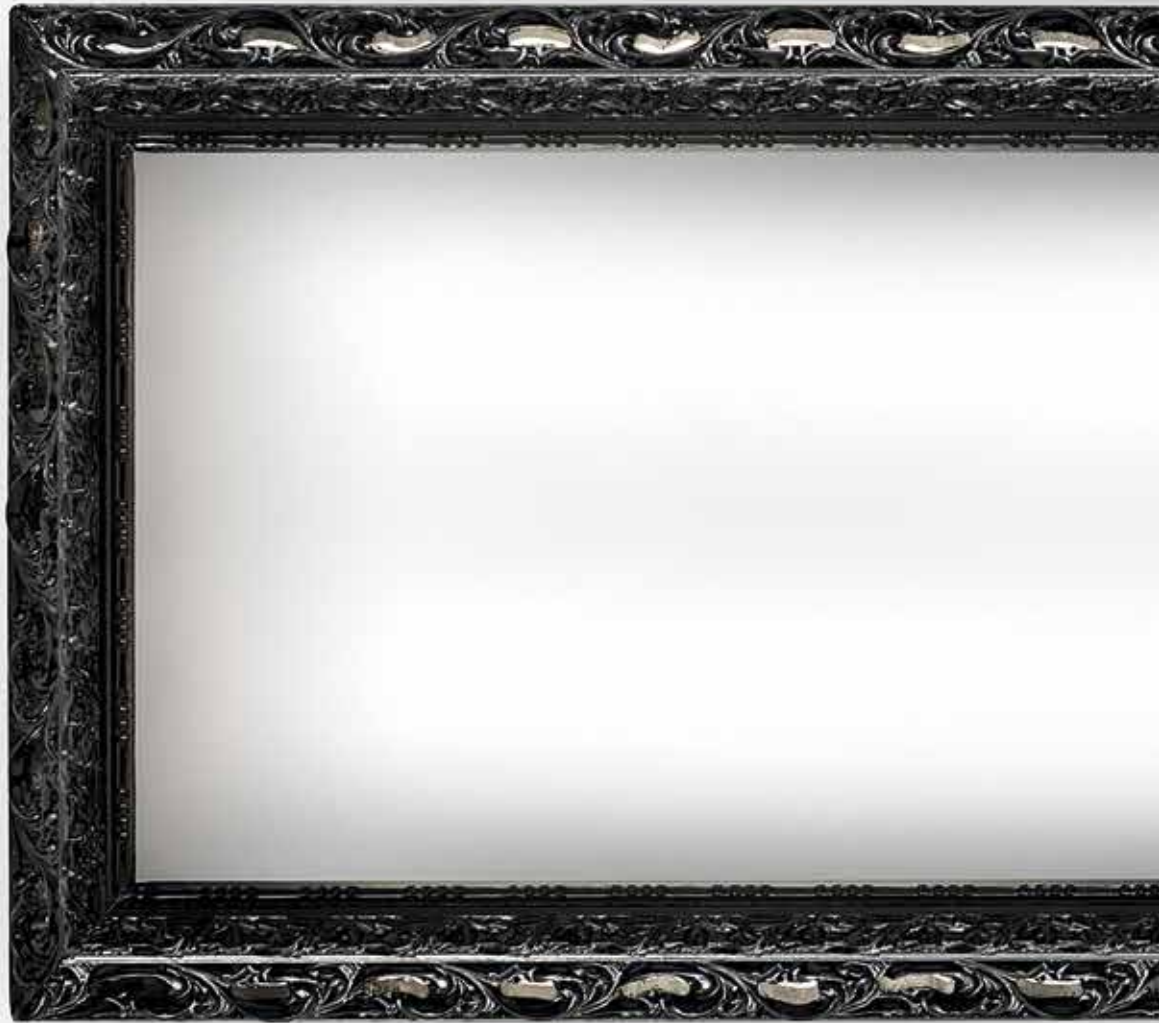

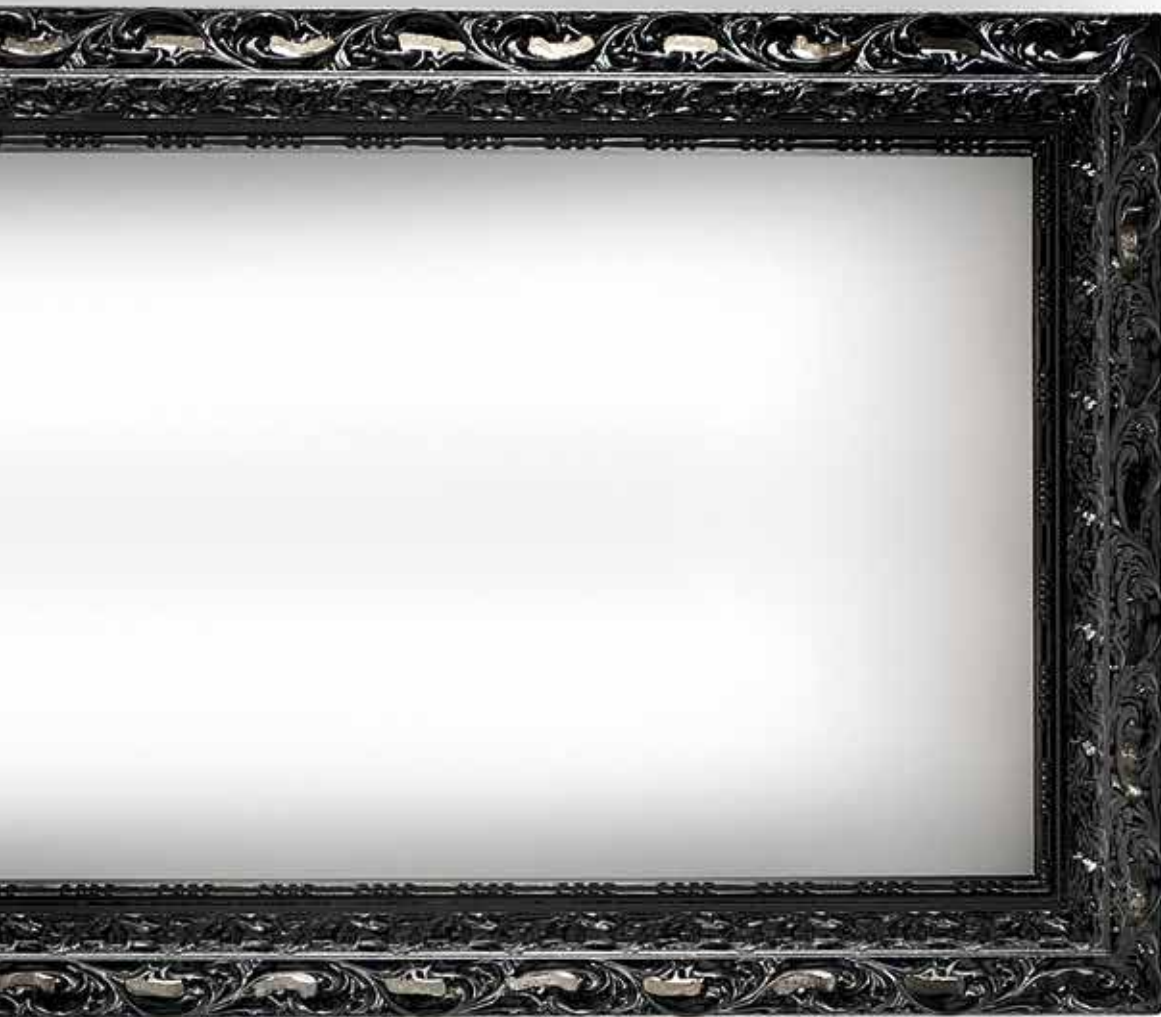

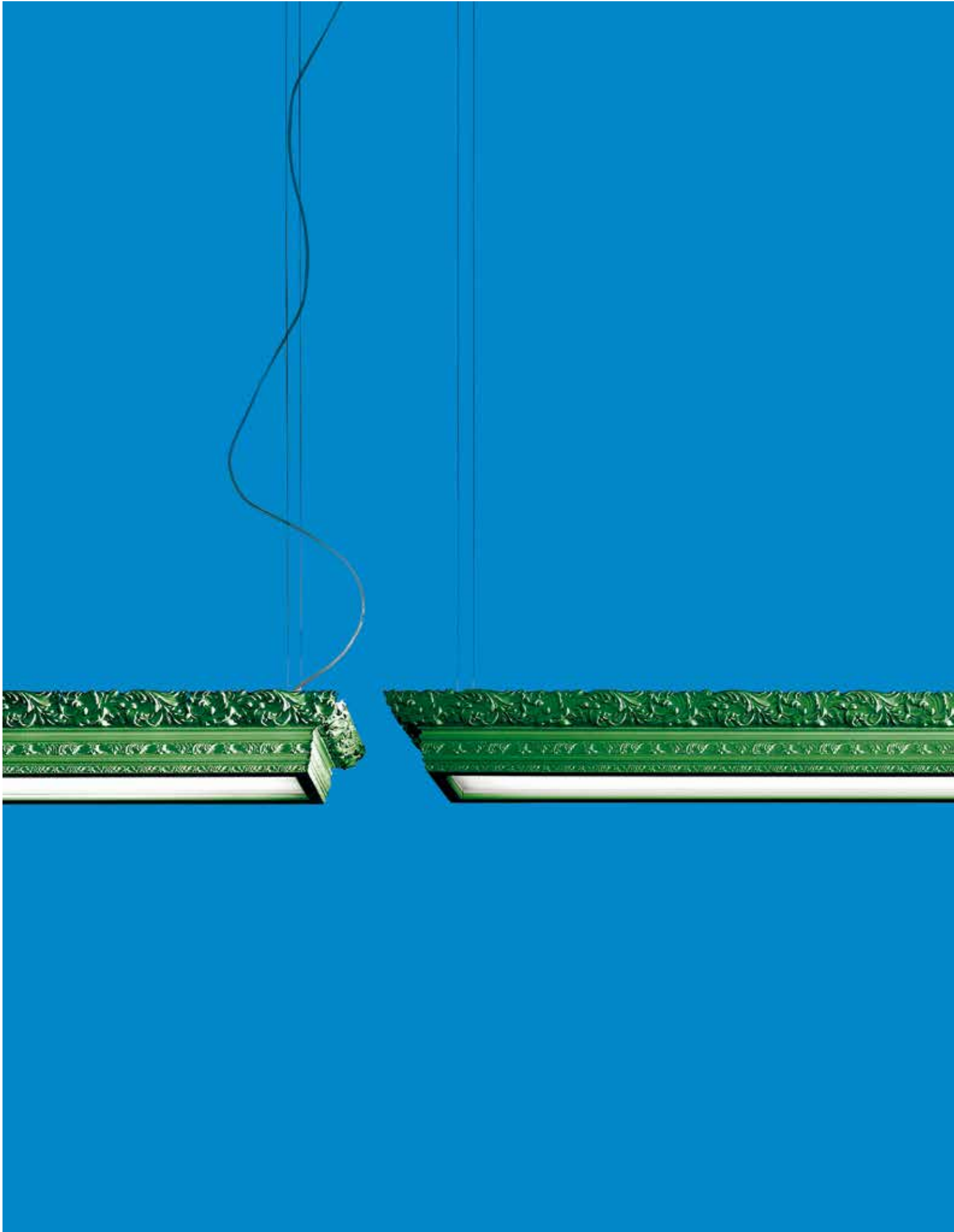

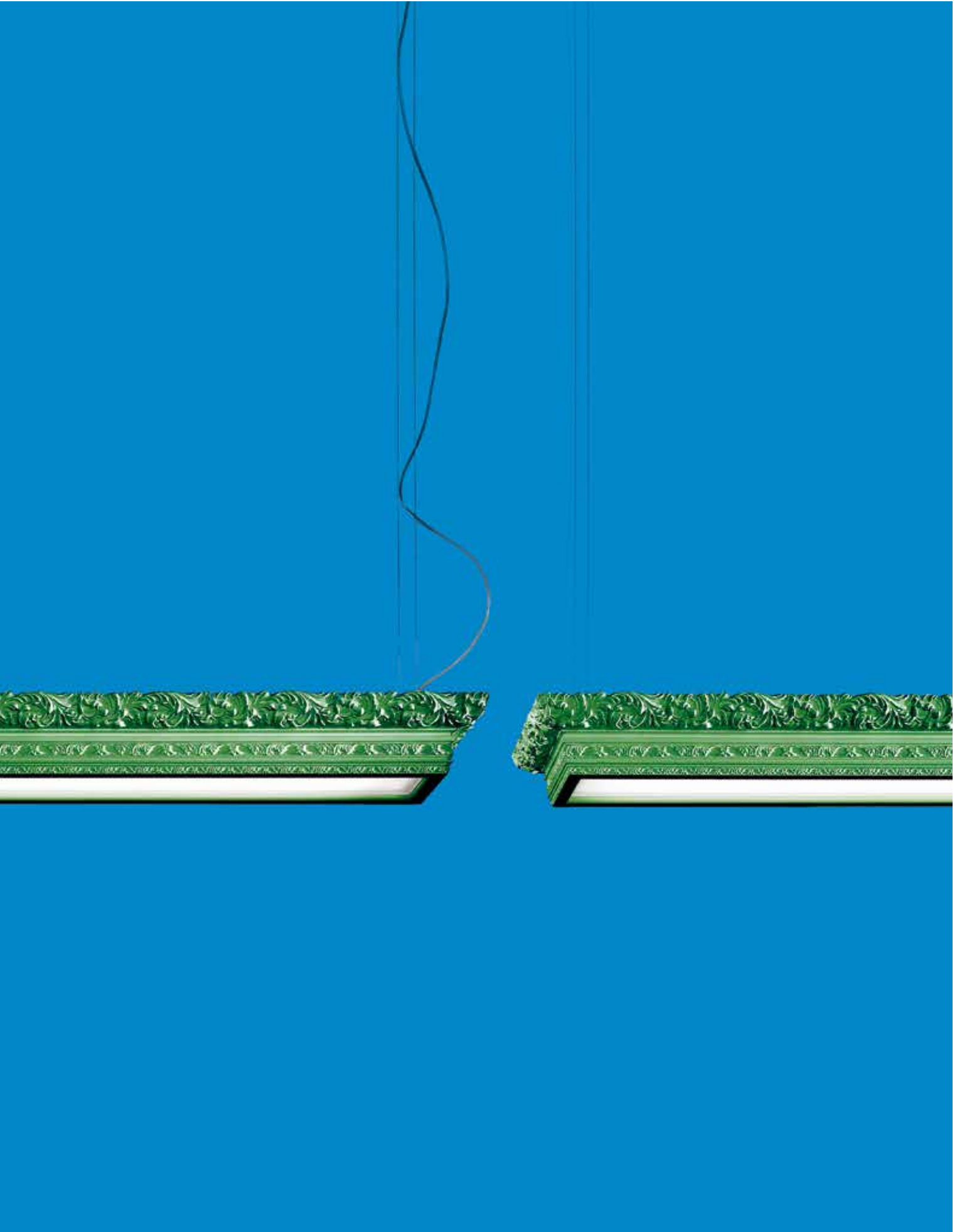

# ARTÈ

Design by: Manuel Vivian

Lampada con struttura in poliuretano laccato e diffusore in policarbonato bianco latte.

Lamp with lacquered polyurethane frame and white polycarbonate diffuser.

Lampe mit lackierter Polyurethanstruktur und Diffusor aus milchweißem Polycarbonat.

Lampe avec une structure en polyuréthane laqué et diffuseur en polycarbonate blanc lait.

Lámpara con estructura de poliuretano lacado y difusor de policarbonato blanco leche.





**WH-M**  
Bianco Opaco

**BK-S**  
Nero Lucido

**GRF-S**  
Verde Felce  
Lucido

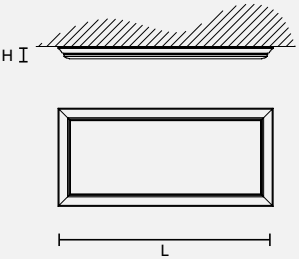
**REP-S**  
Rosso Porpora  
Lucido





**ARTÈ APL4 RC**  

**H** 8 cm 3.15"  
**L** 138 x 63cm 54.30"x 24.80"

**LED** 12 LED 115W  
tot 3000 K - 14500 lm  
DIMMABLE

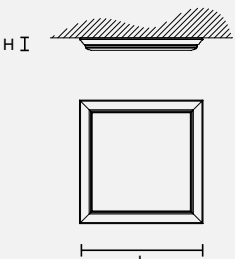
**USA:**  
4 x T5 G5 x 54W max  
Fluorescenza/Fluorescent





**ARTÈ APL4 SQ**  

**H** 8 cm 3.15"  
**L** 78 x 78cm 30.70"x 30.70"

**LED** 4 LED 75W  
tot 3000 K - 10880 lm  
DIMMABLE

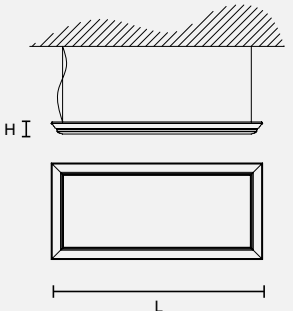
**USA:**  
4 x T5 G5 x 54W max  
Fluorescenza/Fluorescent





**ARTÈ S4 RC**  

**H** 8 cm 3.15"  
**L** 138 x 63cm 54.30"x 24.80"

**UP** 4 LED : 20W  
tot 3000 K - 3000 lm  
**DOWN** 12 LED : 115W  
tot 3000 K - 14500 lm  
DIMMABLE

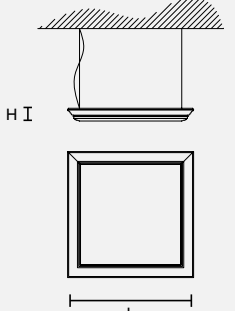
**USA:**  
4 x T5 G5 x 54W max  
Fluorescenza/Fluorescent



**ARTÈ S4 SQ**  

**H** 8 cm 3.15"  
**L** 78 x 78cm 30.70"x 30.70"

**UP** 2 LED : 20W  
tot 3000 K - 2400 lm  
**DOWN** 4 LED : 75W  
tot 3000 K - 10880 lm  
DIMMABLE

**USA:**  
4 x T5 G5 x 54W max  
Fluorescenza/Fluorescent

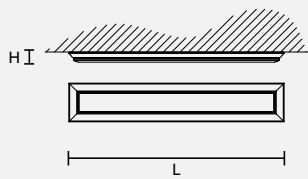



**ARTÈ LINEAR APL1**  

**H** 12 cm 4.75"  
**L** 167x30 cm 65.75" x 11.80"

**LED** 4 LED 38W  
 tot 3000 K - 4800 lm  
 DIMMABLE

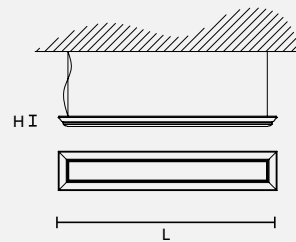
**USA:**  
 1 x T5 G5 x 54W max  
 Fluorescenza/Fluorescent





**ARTÈ LINEAR S1**  

**H** 12 cm 4.75"  
**L** 167x30 cm 65.75" x 11.80"

**UP** 2 LED : 20W  
 tot 3000 K - 2400 lm  
**DOWN** 4 LED : 40W  
 tot 3000 K - 4800 lm  
 DIMMABLE

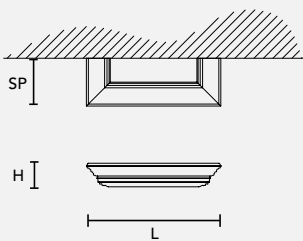
**USA:**  
 1 x T5 G5 x 54W max  
 Fluorescenza/Fluorescent





**ARTÈ A1 45**  

**H** 8 cm 3.15"  
**L** 45 cm 17.70"  
**SP** 16 cm 6.30"

**UP** 1 LED : 5W 3000 K -  
 740 lm  
**DOWN** 1 LED : 10W 3000 K -  
 1200 lm DIMMABLE

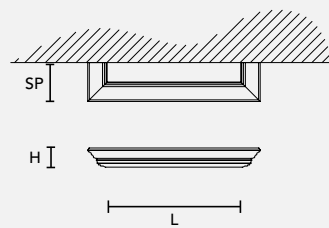
**USA:**  
 1 x TCL 2G11 x 18W max  
 Fluorescenza/Fluorescent



**ARTÈ A1 70**  

**H** 8 cm 3.15"  
**L** 71 cm 27.95"  
**SP** 16 cm 6.30"

**UP** 1 LED : 10W 3000 K -  
 1200 lm  
**DOWN** 1 LED : 20W 3000 K -  
 2720 lm DIMMABLE

**USA:**  
 1 x TCL 2G11 x 36W max  
 Fluorescenza/Fluorescent

OLÀ

Design by:  
Fly Design Studio







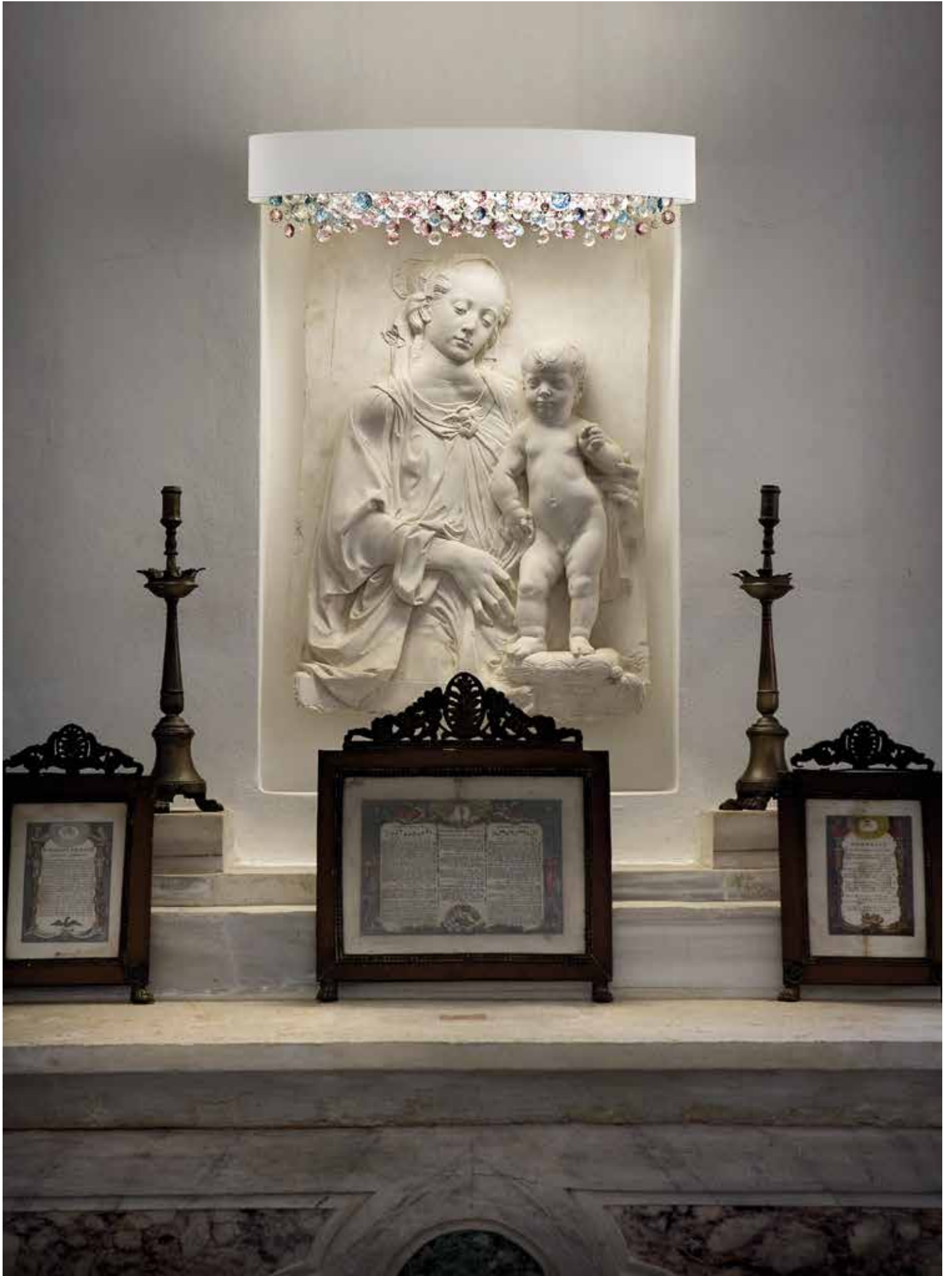





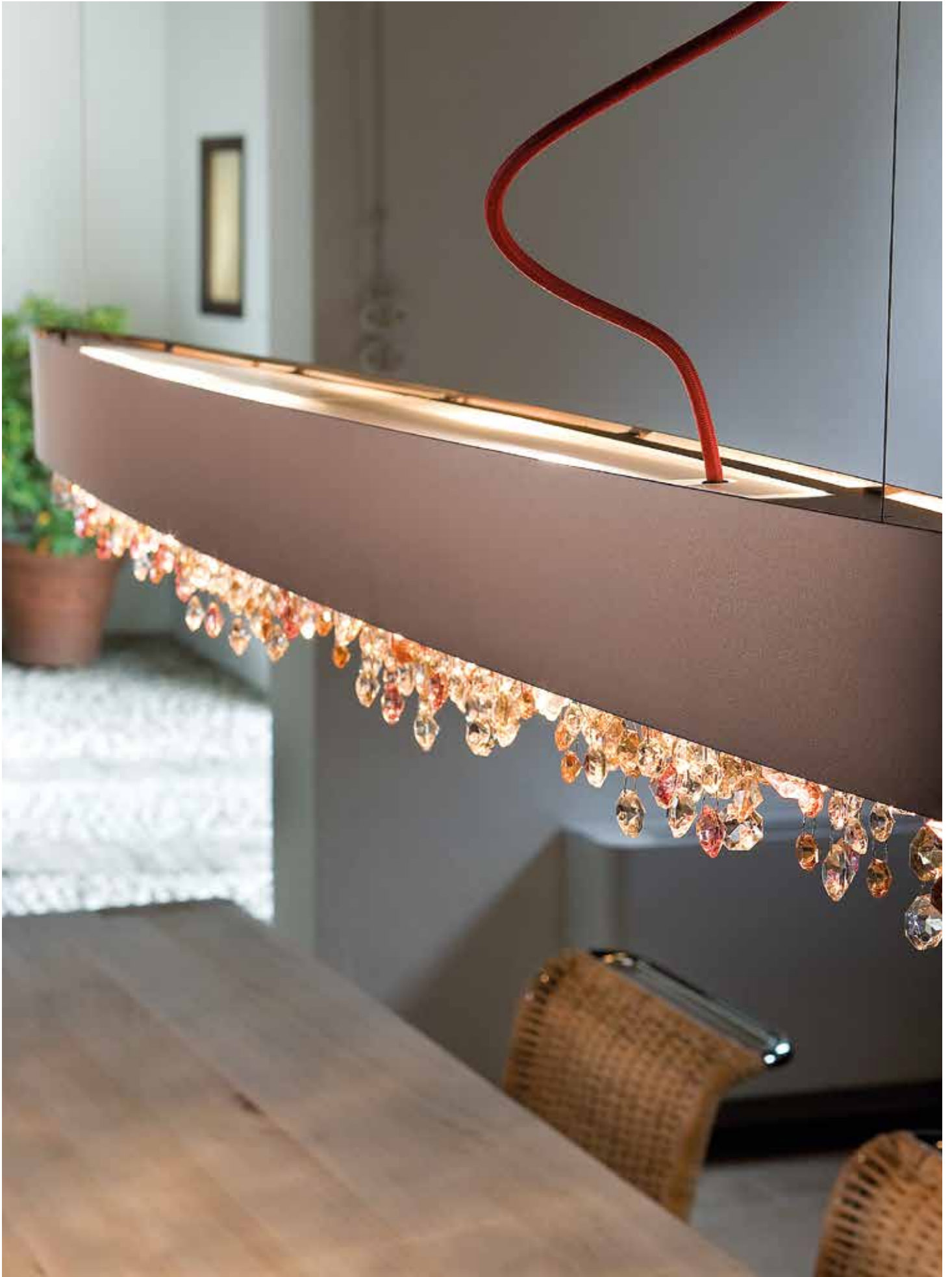

Ola S6 OV 160 COPPER LEAF





Oià A1 OV 30



Oià A2 OV 50











Lampada con struttura in metallo verniciato, pendagli in vetro italiano verniciato.

Powder coated metal frame, coated Italian-glass pendants.

Lampe mit lackierter Metallstruktur, Gehänge aus lackiertem italienischem Glas.

Lampe avec structure en métal verni, breloques en verre italien verni.

Lámpara con estructura de metal barnizado, colgantes de vidrio italiano barnizado.

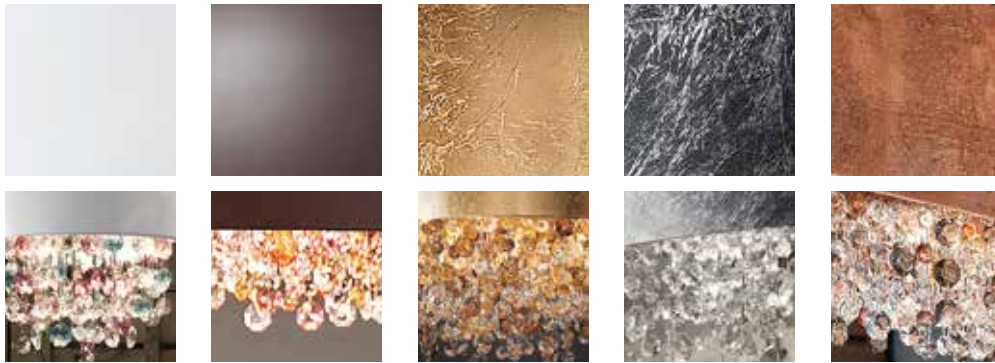

**WH-M**  
**MAT WHITE**  
**FRAME**  
COMES WITH  
**COLD COLORS**  
**PENDANTS**

**P09**  
**MAT BRONZE**  
**FRAME**  
COMES WITH  
**WARM COLORS**  
**PENDANTS**

**F-01**  
**GOLD LEAF**  
**FRAME**  
COMES WITH  
**AMBER COLORS**  
**PENDANTS**

**F-02**  
**SILVER LEAF**  
**FRAME**  
COMES WITH  
**TRANSPARENT**  
**PENDANTS**

**F-03**  
**COPPER LEAF**  
**FRAME**  
COMES WITH  
**COPPER COLORS**  
**PENDANTS**

**OLÀ S2 15** CE

H 18 cm 7.08"  
Ø 15 cm 5.90"

2 x G9 x 40W max

**USA:**  
1 x E12 x 40 W max  
*not included*

---

**LED VERSION:**  
DOWN 7,5W 3000 K - 930 lm  
DIMMABLE

**OLÀ S6 40** CE

H 20 cm 7.87"  
Ø 40 cm 15.74"

6 x E14 x 60W max

**USA:**  
6 x E12 x 40 W max  
*not included*

---

**LED VERSION:**  
UP 14W 3000 K - 1600 lm  
DOWN 14W 3000 K - 1600 lm  
DIMMABLE

**OLÀ S6 60** CE

H 20 cm 7.90"  
Ø 60 cm 23.70"

6 x E27 x 60W max

**USA:**  
6 x E26 x 60 W max  
*not included*

---

**LED VERSION:**  
UP 10,5W 3000 K - 1250 lm  
DOWN 31,5W 3000 K - 3800 lm  
DIMMABLE

**OLÀ S6 90** CE



H 20 cm 7.90"  
Ø 90 cm 35.50"

8 x E27 x 60W max

**USA:**  
8 x E26 x 60 W max  
*not included*

---

**LED VERSION:**  
UP 12,5W 3000 K - 1500 lm  
DOWN 37W 3000 K - 4500 lm  
DIMMABLE

**OLÀ S4 OV 100**  

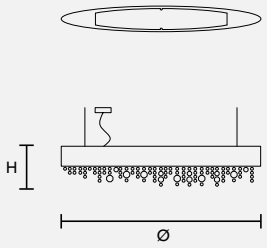



**H** 20 cm 5.11"  
**Ø** 100 x 39.37"  
 13 cm x 5.11"

● 4 x E14 x 60W max

**USA:**  
 ● 4 x E12 x 40 W max  
*not included*

---

**LED VERSION:**  
 UP 8,5W 3000 K - 1000 lm  
 DOWN 25W 3000 K - 3000 lm  
 DIMMABLE

**OLÀ S6 OV 160**  

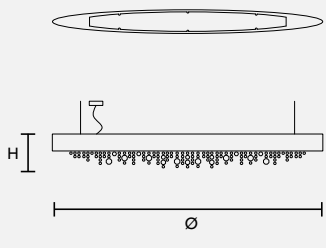



**H** 20 cm 7.90"  
**Ø** 160 x 63.00"  
 14 cm x 5.50"

● 6 x E14 x 60W max

**USA:**  
 ● 6 x E12 x 40 W max  
*not included*

---

**LED VERSION:**  
 UP 19W 3000 K - 2300 lm  
 DOWN 47,5W 3000 K - 5700 lm  
 DIMMABLE

**OLÀ PL6 40**  

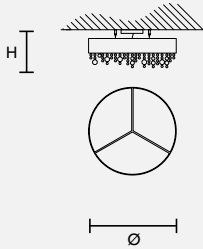



**H** 26 cm 10.23"  
**Ø** 40 cm 15.74"

● 6 x E14 x 60W max

**USA:**  
 ● 6 x E12 x 40 W max  
*not included*

---

**LED VERSION:**  
 UP 14W 3000 K - 1600 lm  
 DOWN 14W 3000 K - 1600 lm  
 DIMMABLE

**OLÀ PL6 60**  

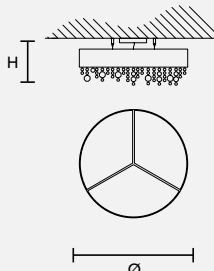



**H** 26 cm 10.23"  
**Ø** 60 cm 23.70"

● 6 x E27 x 60W max

**USA:**  
 ● 6 x E26 x 60 W max  
*not included*

---

**LED VERSION:**  
 UP 10,5W 3000 K - 1250 lm  
 DOWN 31,5W 3000 K - 3800 lm  
 DIMMABLE

**OLÀ PL6 90**  

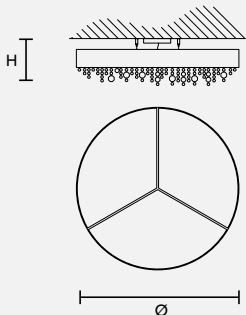



**H** 26 cm 10.23"  
**Ø** 90 cm 35.50"

● 8 x E27 x 60W max

**USA:**  
 ● 8 x E26 x 60 W max  
*not included*

---

**LED VERSION:**  
 UP 12,5W 3000 K - 1500 lm  
 DOWN 37W 3000 K - 4500 lm  
 DIMMABLE

**OLÀ PL4 OV 100**  

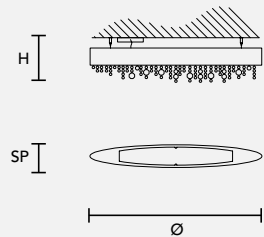



**H** 26 cm 10.23"  
**Ø** 100 cm 39.37"  
 13 cm 5.11"

● 4 x E14 x 60W max

**USA:**  
 ● 4 x E12 x 40 W max  
*not included*

---

**LED VERSION:**  
 UP 8,5W 3000 K - 1000 lm  
 DOWN 25W 3000 K - 3000 lm  
 DIMMABLE

**OLÀ PL6 OV 160**  

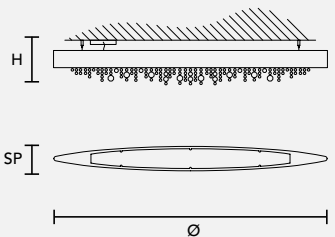



**H** 26 cm 10.23"  
**L** 160 cm 62.99"  
**SP** 13 cm 5.11"

● 6 x E14 x 60W max

**USA:**  
 ● 6 x E12 x 40 W max  
*not included*

---

**LED VERSION:**  
 UP 19W 3000 K - 2300 lm  
 DOWN 47,5W 3000 K - 5700 lm  
 DIMMABLE

**OLÀ A1 OV 30**  

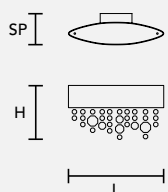

**H** 18 cm 7.08"  
**L** 30 cm 11.81"  
**SP** 10 cm 3.93"

● 1 x R7s 78mm x 150W max

**USA:**  
 ● 1 x E12 x 40 W max  
*not included*

---

**LED VERSION:**  
 UP 6,4W 3000 K - 780 lm  
 DOWN 6,4W 3000 K - 780 lm  
 DIMMABLE

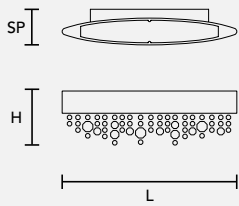

**OLÀ A2 OV 50**



**H** 18 cm 7.08"  
**L** 50 cm 19.70"  
**SP** 12 cm 4.72"

2 x E27 x 60W max

**USA:**

2 x E26 x 60 W max  
*not included*

**LED VERSION:**

UP 5,8W 3000 K - 700 lm  
 DOWN 8W 3000 K - 1000 lm  
 DIMMABLE

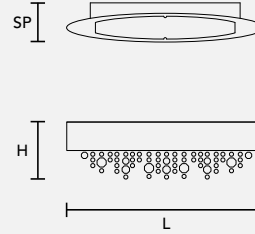

**OLÀ A2 OV 70**



**H** 20 cm 7.90"  
**L** 70 cm 11.82"  
**SP** 15 cm 6.00"

2 x E27 x 60W max

**USA:**

2 x E26 x 60 W max  
*not included*

**LED VERSION:**

UP 10W 3000 K - 1200 lm  
 DOWN 20W 3000 K - 2400 lm  
 DIMMABLE

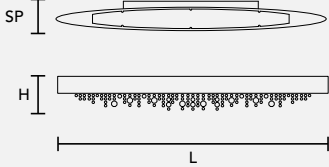

**OLÀ A6 OV 160**



**H** 20 cm 7.90"  
**L** 160 cm 63.00"  
**SP** 20 cm 7.90"

6 x E14 x 60W max

**USA:**

6 x E12 x 40 W max  
*not included*

**LED VERSION:**

UP 19W 3000 K - 2300 lm  
 DOWN 47,5W 3000 K - 5700 lm  
 DIMMABLE

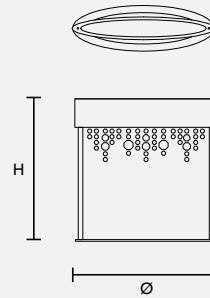

**OLÀ TL2**



**H** 50 cm 19.70"  
**Ø** 50 cm 19.70"

2 x E27 x 60W max

**USA:**

2 x E26 x 60 W max  
*not included*

**LED VERSION:**

UP 7W 3000 K - 850 lm  
 DOWN 10W 3000 K - 1200 lm  
 DIMMABLE

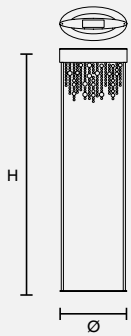

**OLÀ STL2**



**H** 180 cm 70.90"  
**Ø** 50 cm 19.70"

2 x E27 x 60W max

**USA:**

2 x E26 x 60 W max  
*not included*

**LED VERSION:**

UP 7W 3000 K - 850 lm  
 DOWN 10W 3000 K - 1200 lm  
 DIMMABLE

# TESSUTI

Design by:  
Studio Stile Masiero



Dome S4 100











# ROUND

Design by: Studio Stile Masiero

Strutture metalliche dalle molteplici forme sono elegantemente ricoperte da preziosi tessuti.

Different shaped, metallic structures are elegantly covered in precious fabrics.

Metallstrukturen in unterschiedlichsten Formen werden elegant von kostbaren Geweben überzogen.

Structures métalliques aux formes différentes recouvertes d'une façon élégante de précieux tissus.

Estructuras metálicas de múltiples formas son recubiertas elegantemente de preciados tejidos.

**FABRIC:** PONGE

**COLORS:** IVORY, WHITE, BLACK

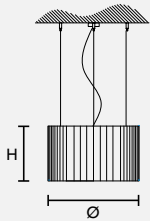

## ROUND S2 50



H 30 cm 11.90"  
Ø 50 cm 19.70"

2 x E14 x 40W max

**USA:**  
2x E12 x 40 W max  
not included

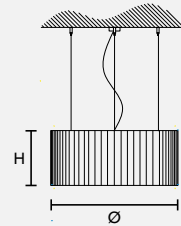

## ROUND S2 70



H 30 cm 11.90"  
Ø 70 cm 27.60"

2 x E27 x 60W max

**USA:**  
2x E26 x 60 W max  
not included

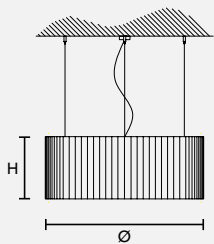

## ROUND S4 90



H 30 cm 11.90"  
Ø 90 cm 35.50"

4 x E27 x 60W max

**USA:**  
4x E26 x 60 W max  
not included

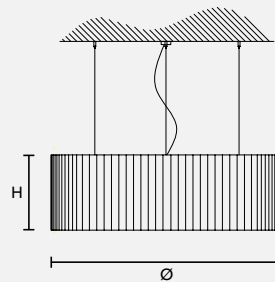

## ROUND S6 150



H 45 cm 17.80"  
Ø 150 cm 59.10"

6 x E27 x 60W max

**USA:**  
6x E26 x 60 W max  
not included

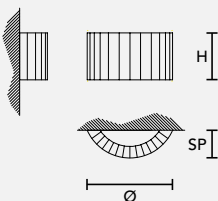

## ROUND A1



H 21 cm 8.30"  
Ø 40 cm 15.80"  
SP 13 cm 5.20"

1 x E14 x 40W max

**USA:**  
1x E12 x 40 W max  
not included







# CONE

Design by: Studio Stile Masiero

Strutture metalliche dalle molteplici forme sono elegantemente ricoperte da preziosi tessuti.

Different shaped, metallic structures are elegantly covered in precious fabrics.

Metallstrukturen in unterschiedlichsten Formen werden elegant von kostbaren Geweben überzogen.

Structures métalliques aux formes différentes recouvertes d'une façon élégante de précieux tissus.

Estructuras metálicas de múltiples formas son recubiertas elegantemente de preciados tejidos.

**FABRIC:** PONGE

**COLORS:** IVORY, WHITE, BLACK

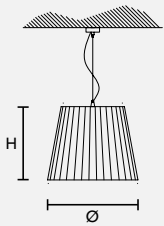

## CE F CONE S2 40

H 30 cm 11.90"  
Ø 40 cm 15.80"

2 x E27 x 60W max

USA:

2x E26 x 60 W max  
not included

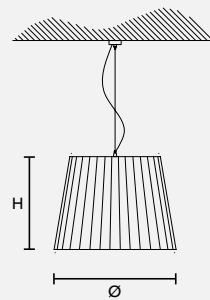

## CE F CONE S3 60

H 45 cm 17.80"  
Ø 60 cm 23.70"

3 x E27 x 60W max

USA:

3x E26 x 60 W max  
not included

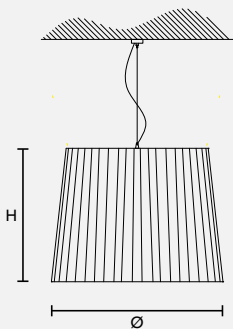

## CE F CONE S3 90

H 70 cm 27.55"  
Ø 90 cm 35.45"

3 x E27 x 60W max

USA:

3x E26 x 60 W max  
not included

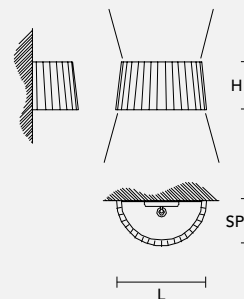

## CE F CONE A1

H 21 cm 8.30"  
Ø 40 cm 15.80"  
SP 20 cm 7.90"

1 x E14 x 40W max

USA:

1x E14 x 40 W max  
not included













# DOME

Design by: Studio Stile Masiero

Strutture metalliche dalle molteplici forme sono elegantemente ricoperte da preziosi tessuti.

Different shaped, metallic structures are elegantly covered in precious fabrics.

Metallstrukturen in unterschiedlichsten Formen werden elegant von kostbaren Geweben überzogen.

Structures métalliques aux formes différentes recouvertes d'une façon élégante de précieux tissus.

Estructuras metálicas de múltiples formas son recubiertas elegantemente de preciados tejidos.

**FABRIC:** PONGE

**COLORS:** IVORY, WHITE, BLACK

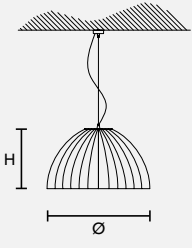



**DOME S1 60** CE 

**H** 35 cm 13.80"  
**Ø** 60 cm 23.70"

1 x E27 x 60W max

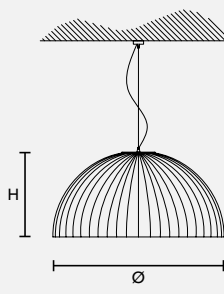
**USA:**  
1x E26 x 60 W max  
not included





**DOME S3 100** CE 

**H** 55 cm 21.70"  
**Ø** 100 cm 39.40"

3 x E27 x 60W max

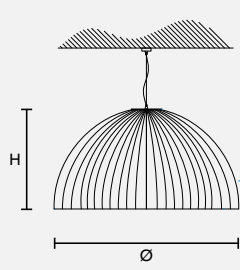
**USA:**  
3x E26 x 60 W max  
not included





**DOME S4 120** CE 

**H** 65 cm 25.60"  
**Ø** 120 cm 47.25"

4 x E27 x 60W max

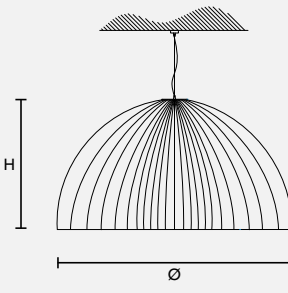
**USA:**  
4x E26 x 60 W max  
not included





**DOME S5 150** CE 

**H** 100 cm 39.40"  
**Ø** 150 cm 59.05"

5 x E27 x 60W max

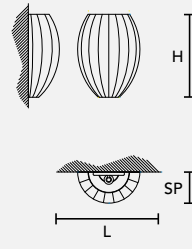
**USA:**  
5x E26 x 60 W max  
not included



**DOME A1** CE 

**H** 40 cm 15.80"  
**Ø** 32 cm 12.60"  
**SP** 17 cm 6.70"

1 x E14 x 40W max

**USA:**  
1x E12 x 40 W max  
not included







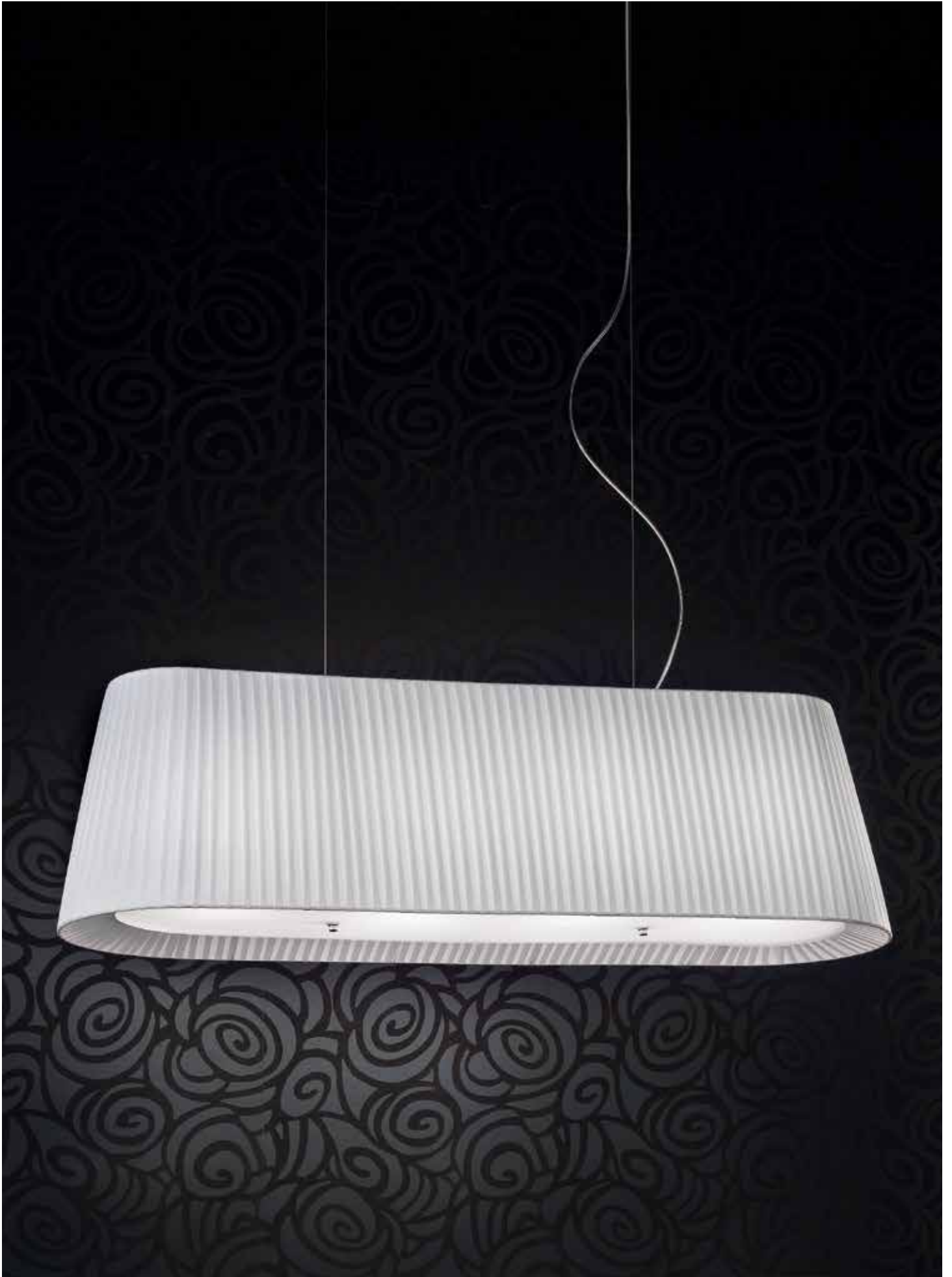

# OVAL

Design by: Studio Stile Masiero

Strutture metalliche dalle molteplici forme sono elegantemente ricoperte da preziosi tessuti.

Different shaped, metallic structures are elegantly covered in precious fabrics.

Metallstrukturen in unterschiedlichsten Formen werden elegant von kostbaren Geweben überzogen.

Structures métalliques aux formes différentes recouvertes d'une façon élégante de précieux tissus.

Estructuras metálicas de múltiples formas son recubiertas elegantemente de preciados tejidos.

**FABRIC:** PONGE

**COLORS:** IVORY, WHITE, BLACK

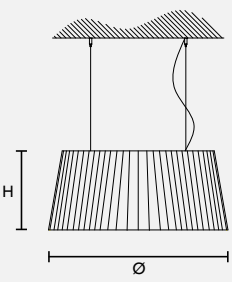



**OVAL S2 90** CE 

**H** 40 cm 15.80"  
**L** 90 cm 35.45"  
**SP** 36 cm 14.20"

• 2 x E27 x 60W max

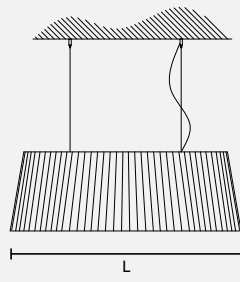
**USA:**  
 • 2x E26 x 60 W max  
*not included*





**OVAL S4 120** CE 

**H** 40 cm 15.80"  
**L** 120 cm 47.30"  
**SP** 36 cm 14.20"

• 4 x E27 x 60W max

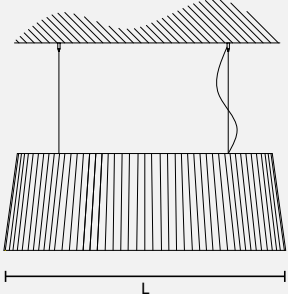
**USA:**  
 • 4x E26 x 60 W max  
*not included*





**OVAL S5 150** CE 

**H** 50 cm 19.70"  
**L** 150 cm 59.05"  
**SP** 36 cm 14.20"

• 5 x E27 x 60W max

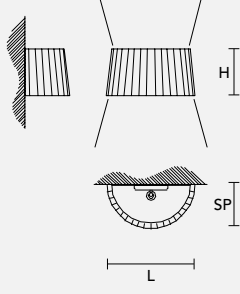
**USA:**  
 • 5x E26 x 60 W max  
*not included*



**OVAL A1** CE 

**H** 21 cm 8.25"  
**L** 40 cm 15.75"  
**SP** 20 cm 7.90"

• 1 x E14 x 40W max

**USA:**  
 • 1x E12 x 40 W max  
*not included*



Square A2



Square A2





# SQUARE

Design by: Studio Stile Masiero

Strutture metalliche dalle molteplici forme sono elegantemente ricoperte da preziosi tessuti.

Different shaped, metallic structures are elegantly covered in precious fabrics.

Metallstrukturen in unterschiedlichsten Formen werden elegant von kostbaren Geweben überzogen.



Structures métalliques aux formes différentes recouvertes d'une façon élégante de précieux tissus.

Estructuras metálicas de múltiples formas son recubiertas elegantemente de preciados tejidos.

**FABRIC:** COTONETTE

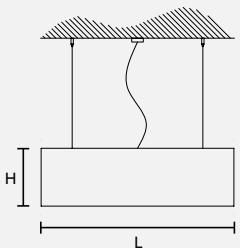
**COLORS:** IVORY, WHITE, BLACK





**SQUARE S4 100**  

**H** 30 cm 11.90"  
**L** 100 cm 39.40"  
x100 cm x 39.40"

● 4 x E27 x 60W max

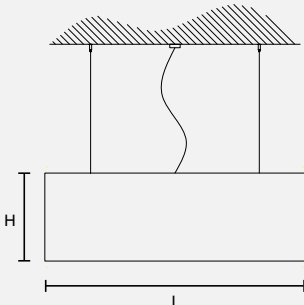
**USA:**  
● 4x E26 x 60 W max  
not included





**SQUARE S6 150**  

**H** 60 cm 23.70"  
**L** 150 cm 59.10"  
x150 cm x 59.10"

● 6 x E27 x 60W max

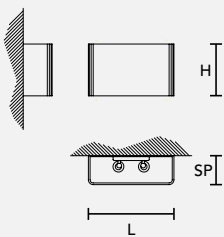
**USA:**  
● 6x E26 x 60 W max  
not included



**SQUARE A2**  

**H** 22 cm 8.70"  
**L** 36 cm 14.20"  
**SP** 12 cm 4.80"

● 2 x E27 x 60W max

**USA:**  
● 2x E26 x 60 W max  
not included

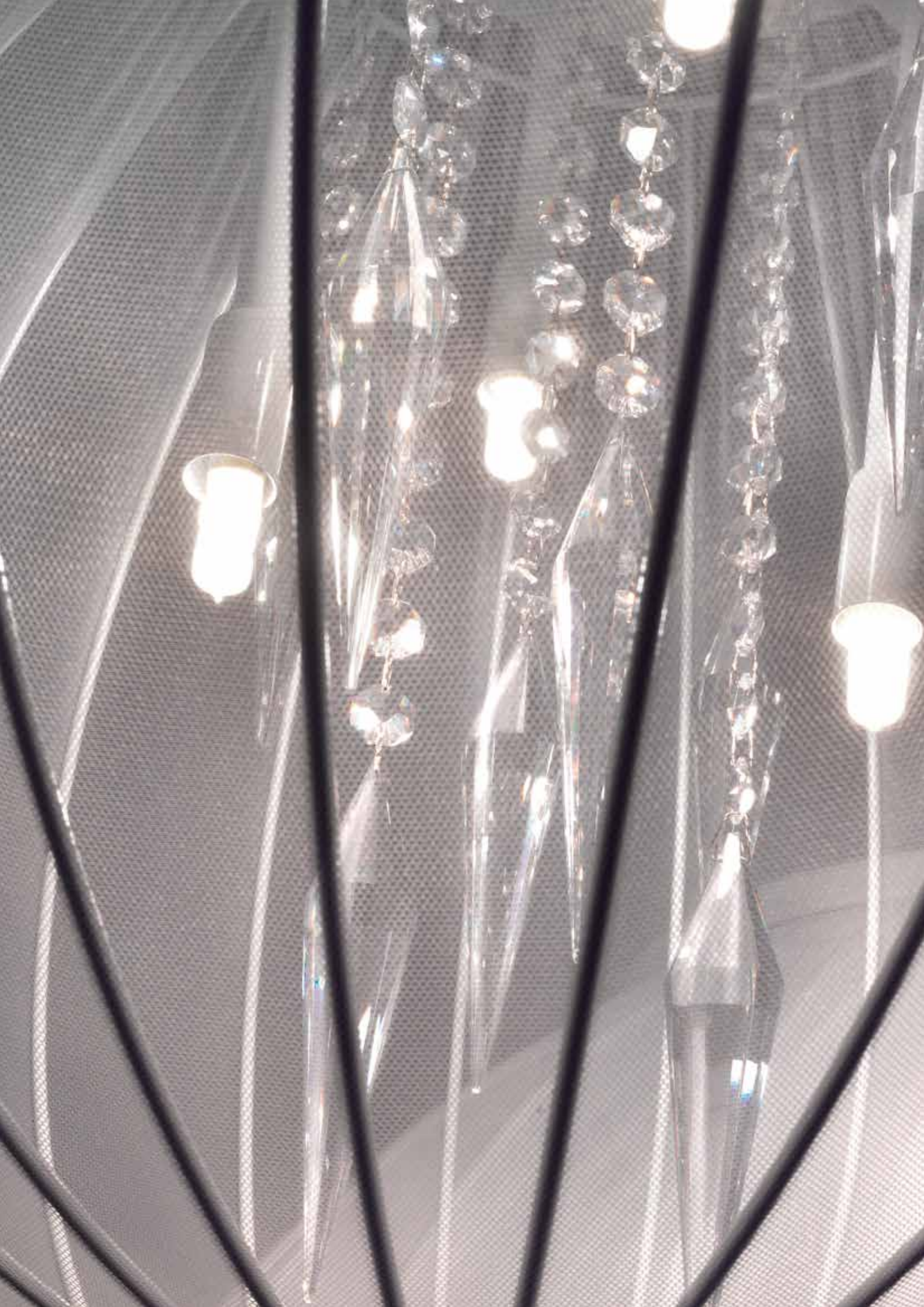

Sphere S4 50

Sphere S6 80







# SPHERE

Design by: Studio Stile Masiero

Strutture metalliche dalle molteplici forme sono elegantemente ricoperte da preziosi tessuti.

Different shaped, metallic structures are elegantly covered in precious fabrics.

Metallstrukturen in unterschiedlichsten Formen werden elegant von kostbaren Geweben überzogen.

Structures métalliques aux formes différentes recouvertes d'une façon élégante de précieux tissus.

Estructuras metálicas de múltiples formas son recubiertas elegantemente de preciados tejidos.

**FABRIC:** STRETCH

**COLORS:** WHITE

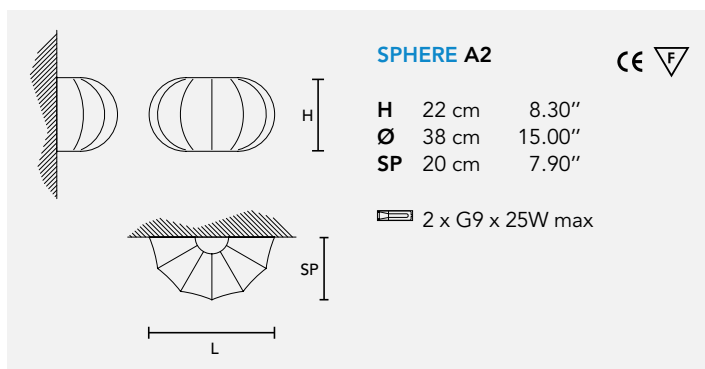
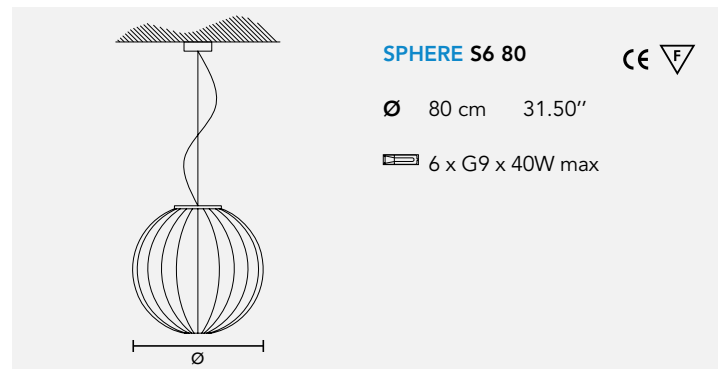
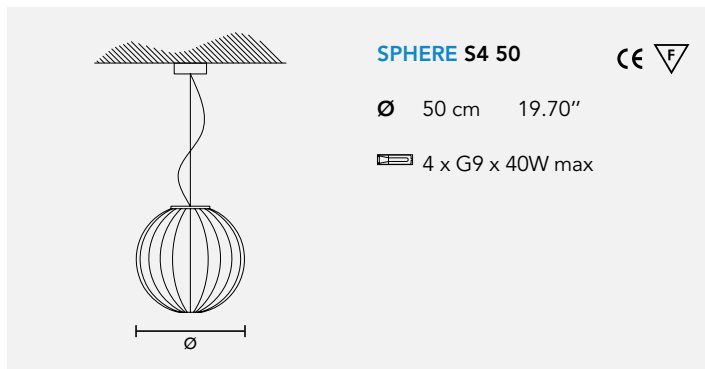

# SLIM

Design by:  
Manuel Vivian



Slim TL1P

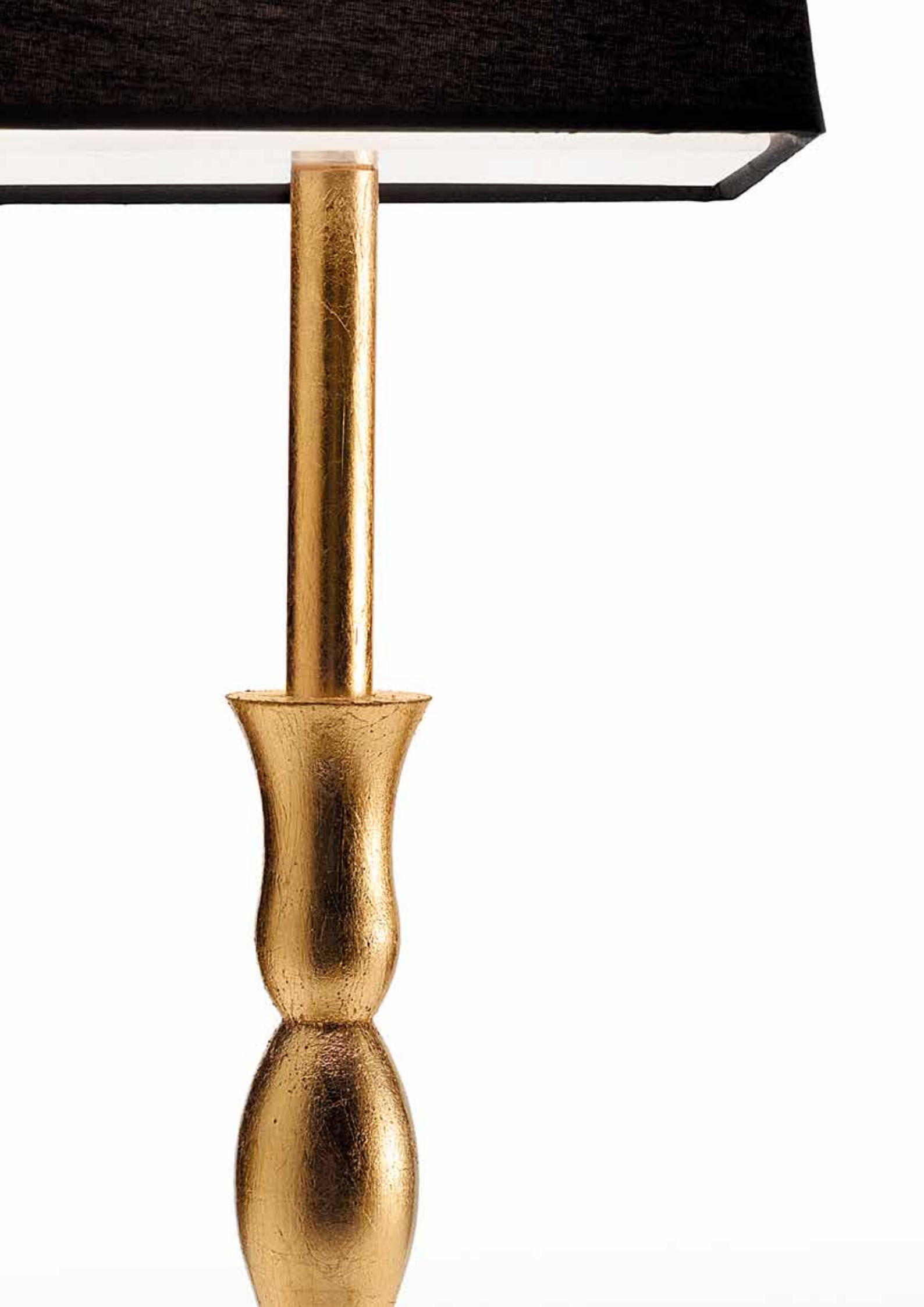













# SLIM

Design by: Manuel Vivian

Lampada con struttura in metallo verniciato o decorato a foglia e paralume in prezioso tessuto accoppiato.

Lamp with metal structure either enamelled or foil decorated and lampshade in precious, double-face fabric.

Lampe mit lackierter oder mit Folie dekoriertes Metallstruktur und Lampenschirm aus kostbarem kaschiertem Gewebe.

Lampe avec structure en métal verni ou décoré à feuille d'or et abat-jour en précieux tissu doubleface.

Lámpara con estructura de metal pintado y decorado de hoja y pantalla de precioso tejido acoplado.



**F-01**  
Foglia oro

**WH-M**  
Bianco Opaco

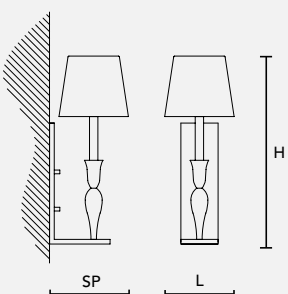



**SLIM A1** 

<b>H</b>	42 cm	16.55"
<b>L</b>	16 cm	6.30"
<b>SP</b>	18 cm	7.10"

● 1 x E14 x 60W max

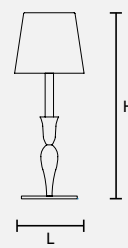
**USA:**  
● 1x E12 x 40 W max  
*not included*





**SLIM TL1P** 

<b>H</b>	40 cm	15.80"
<b>L</b>	16 cm	6.30"
	x 16 cm	x 7.10"

● 1 x E14 x 60W max

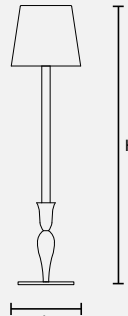
**USA:**  
● 1x E12 x 40 W max  
*not included*



**SLIM TL1G** 

<b>H</b>	60 cm	23.70"
<b>L</b>	16 cm	6.30"
	x 16 cm	x 6.30"

● 1 x E14 x 60W max

**USA:**  
● 1x E12 x 40 W max  
*not included*

# MIR

Design by:  
Fly Design Studio



Mir S3





Mir TL2











# MIR

Design by: Fly Design Studio

Lampada con montatura in metallo cromato, diffusore di luce in vetro triplex, sfere in cristallo trasparente.

Chrome plated metal frame, triplex blown glass sphere, transparent crystal balls.

Leuchte mit verchromter Metallfassung, Lichtdiffusor aus Triplex Glas, Kugeln aus transparentem Kristall.

Lampe avec monture en métal chromé, diffuseur de lumière en verre triplex, sphères en cristal transparent.



Lámpara con cuerpo de metal cromado, difusor de luz de vidrio triplex, esfera de cristal transparente.

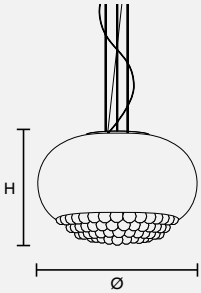

## WH

Bianco Lucido







**MIR S3**   

H 30 cm 11.80"  
 Ø 45 cm 17.70"

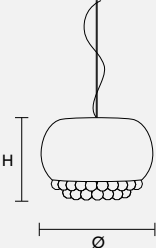
3 x E14 x 40W max

**USA:**  
 3 x E12 x 40 W max  
*not included*





**MIR S2**   

H 25 cm 9.95"  
 Ø 30 cm 11.80"

2 x E14 x 40W max

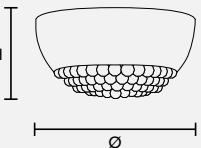
**USA:**  
 2 x E12 x 40 W max  
*not included*







**MIR PL6**  

H 25 cm 9.95"  
 Ø 45 cm 17.70"

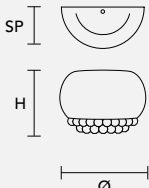
6 x E14 x 40W max

**USA:**  
 6 x E12 x 40 W max  
*not included*





**MIR A1**   

H 22 cm 8.66"  
 L 30 cm 11.80"  
 SP 15 cm 5.90"

1 x E27 x 60W max

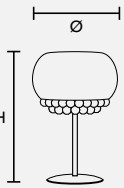
**USA:**  
 1 x E26 x 60 W max  
*not included*





**MIR TL2**  

H 45 cm 17.70"  
 Ø 30 cm 11.80"

2 x E14 x 40W max

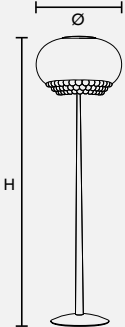
**USA:**  
 2 x E12 x 40 W max  
*not included*



**MIR STL3**  

H 185 cm 72.85"  
 Ø 45 cm 17.70"

3 x E14 x 40W max

**USA:**  
 3 x E12 x 40 W max  
*not included*

# BLOB

Design by:  
Fly Design Studio

Blob A2 45









# BLOB

Design by: Fly Design Studio

Lampada con struttura in metallo verniciato.

Powder coated metal frame.

Lampe mit lackierter Metallstruktur

Lampe avec structure en métal verni.

Lámpara con estructura de metal barnizado.





**F-02**  
Foglia Argento

**F-01**  
Foglia Oro

**WH-S**  
Bianco Lucido

**PR-S**  
Magenta Lucido



**BK-S**  
Nero Lucido

**BLOB A2 45**  

<b>H</b>	45 cm	17.80"
<b>Ø</b>	18 cm	7.10"
<b>SP</b>	20 cm	7.90"

UP 1 LED 7,5 W – 3000 K – 930 lm  
DOWN 1 LED 7,5 W – 3000 K – 930 lm  
DIMMABLE

**USA:**  
 2 x E12 x 40 W max  
*not included*

**BLOB A2 26**  

<b>H</b>	26 cm	10.30"
<b>Ø</b>	10 cm	4.00"
<b>SP</b>	12 cm	4.80"

UP 1 LED 4 W – 3000 K – 500 lm  
DOWN 1 LED 4 W – 3000 K – 500 lm  
DIMMABLE

**USA:**  
 2 x E12 x 40 W max  
*not included*



# KIOCCIA

Design by:  
Studio Stile Masiero













Kioccia PL1 C

Kioccia PL1 L



# KIOCCIA

Design by: Studio Stile Masiero

Spot ad incasso e lampada con montatura in metallo cromato, pendagli in cristallo SWAROVSKI® ELEMENTS colorato.

Chrome plated recessed, ceiling light and suspension. Coloured SWAROVSKI® ELEMENTS crystal pendants.



Einbauspots und Leuchte mit Metallfassung Ausführung chrom, Kristallpendel aus farbigen SWAROVSKI® ELEMENTS.

Spot à encastrément et lampe avec monture en métal chromé, pendeloques en cristal SWAROVSKI® ELEMENTS coloré.

Foco empotrable y lámpara con cuerpo de metal cromado, colgantes de cristal SWAROVSKI® ELEMENTS colorado.





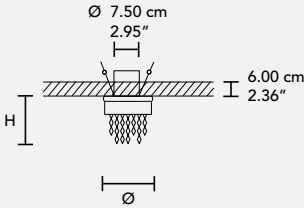

**TR** Trasparente      **SA** Saphire      **VI** Viola      **GR** Light Peridot      **AM** Ambra      **RE** Rosso

**KIOCCIA CORTA**   



**H** 9 cm 3.55"  
**Ø** 9 cm 3.55"

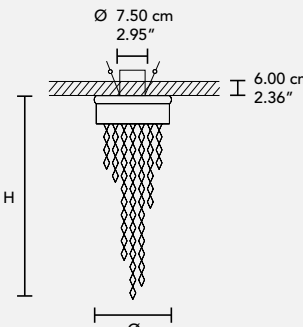

 1 x GU 5.3 x 35W max  
Dicroica/Dichroic  
12 Volt Low Voltage

**KIOCCIA LUNGA**   



**H** 25 cm 9.85"  
**Ø** 9 cm 3.55"

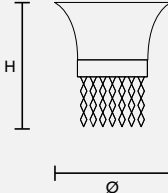

 1 x GU 5.3 x 35W max  
Dicroica/Dichroic  
12 Volt Low Voltage

**KIOCCIA PL1 C**  



**H** 15 cm 5.90"  
**Ø** 16 cm 6.29"

 1 x GU 10 x 50W max  
Dicroica/Dichroic

**KIOCCIA PL1 L**  

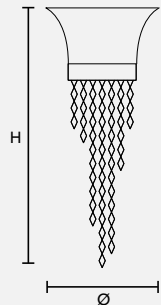

**H** 35 cm 13.77"  
**Ø** 16 cm 6.29"

 1 x GU 10 x 50W max  
Dicroica/Dichroic



# AUREA

Design by:  
Studio Stile Masiero







Aurea 35 S5





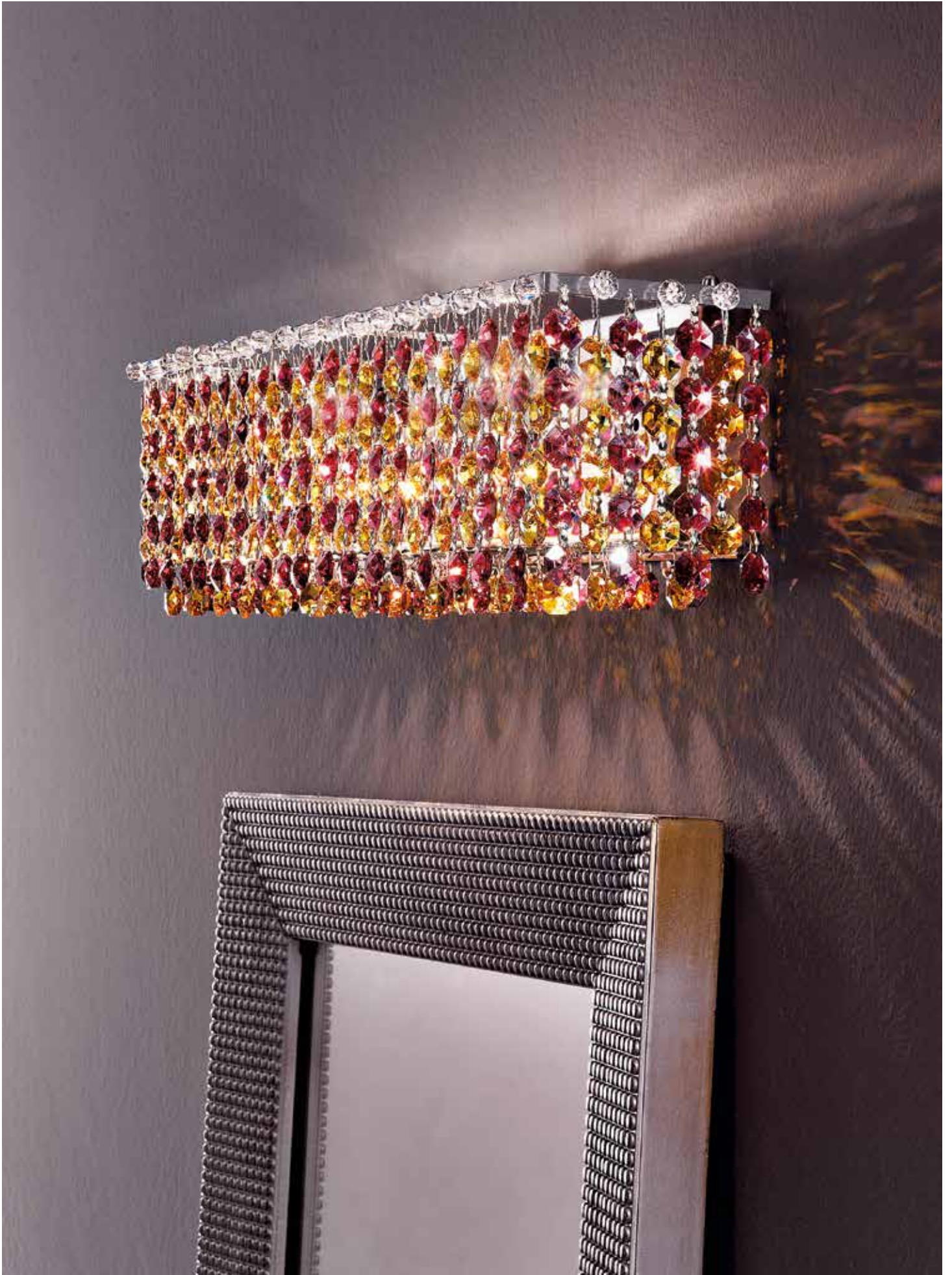







Aurea 10 TL1



Aurea 15 TL1

Aurea 10 TL1





Aurea 55 PL6



# AUREA

Design by: Studio Stile Masiero

Lampada con montatura in metallo cromato, pendagli in cristallo SWAROVSKI® ELEMENTS colorato.

Chrome plated ceiling light and suspension. Coloured SWAROVSKI® ELEMENTS crystal pendants.

Leuchte mit Metallfassung Ausführung chrom, Kristallpendel aus farbigen SWAROVSKI® ELEMENTS.

Lampe avec monture en métal chromé, pendeloques en cristal SWAROVSKI® ELEMENTS coloré.

Lámpara con cuerpo de metal cromado, colgantes de cristal SWAROVSKI® ELEMENTS colorado.



**TR**  
Trasparente

**SA**  
Saphire

**VI**  
Viola

**GR**  
Light Peridot

**AM**  
Ambra

**RE**  
Rosso

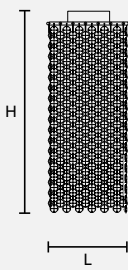

**AUREA 15 PL1** CE

H 30 cm 12"  
L 15x15 cm 5.91"x 5.91"

1 x E27 x 60W max

**USA:**  
 1 x E26 x 60 W max  
*not included*

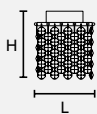

**AUREA 10 PL1** CE

H 12 cm 4.73"  
L 10x10 cm 3.95"x 3.95"

1 x G9 x 40W max

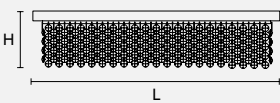

**AUREA 55 PL6** CE

H 13 cm 5.12"  
L 55x55 cm 21.65"x 21.65"

6 x G9 x 40W max

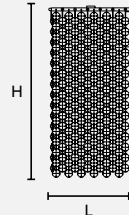

**AUREA 15 A1** CE

H 30 cm 11.80"  
L 15 cm 5.91"  
SP 16 cm 6.30"

1 x E27 x 60W max

**USA:**  
 1 x E26 x 60 W max  
*not included*

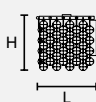

**AUREA 10 A1** CE

H 10 cm 3.95"  
L 10 cm 3.95"  
SP 11 cm 4.33"

1 x G9 x 40W max

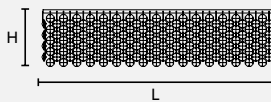

**AUREA 40 A2** CE

H 10 cm 3.95"  
L 40 cm 15.76"  
SP 10 cm 3.95"

2 x G9 x 40W max

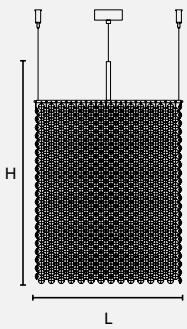

**AUREA 35 S5**



H 55 cm 21.65"  
L 35x35 cm 13.80"x13.80"

5 x E27 x 60W max

USA:  
1 x E26 x 60 W max  
not included

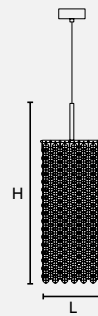

**AUREA 15 S1**



H 37 cm 14.80"  
L 15x15 cm 5.91"x 5.91"

1 x E27 x 60W max

USA:  
1 x E26 x 60 W max  
not included



**AUREA 10 S1**



H 20 cm 7.90"  
L 10x10 cm 3.95"x 3.95"

1 x G9 x 40W max

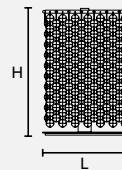

**AUREA 15 TL1**



H 24 cm 9.45"  
L 15x15 cm 5.91"x 5.91"

1 x E27 x 60W max

USA:  
1 x E26 x 60 W max  
not included

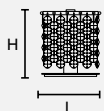

**AUREA 10 TL1**



H 13 cm 5.12"  
L 10x10 cm 3.95"x 3.95"

1 x G9 x 40W max

# CUBIX

Design by:  
Studio Stile Masiero

Cubix S1

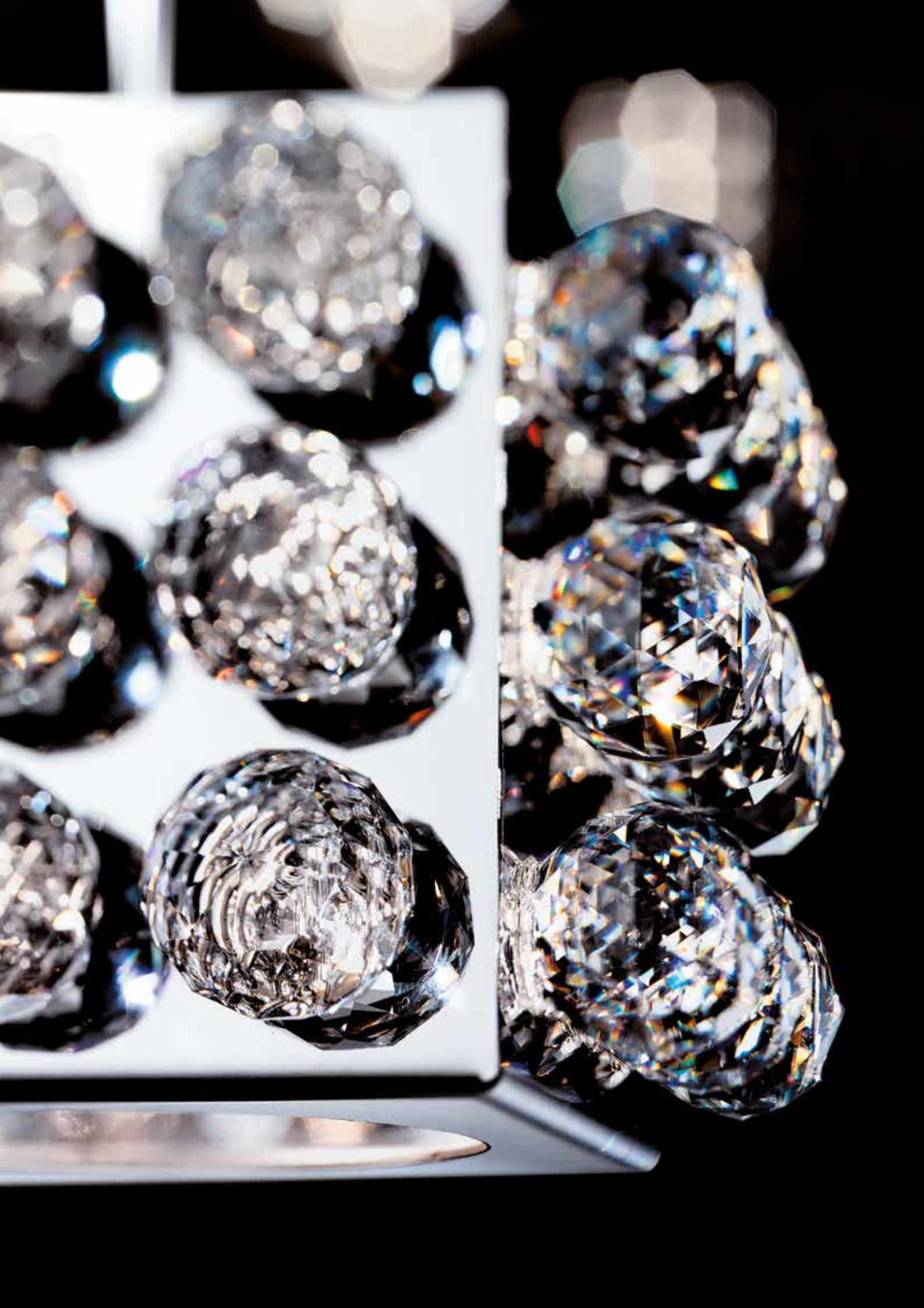











Cubix A1



# CUBIX

Design by: Studio Stile Masiero

Lampada in acciaio inox  
AISI 304. Cristallo  
trasparente.

Polished stainless steel  
frame AISI 304.  
Transparent crystal.

Lampe im rostfreien  
Stahl AISI 304,  
anhänger in Kristall.

Lampe en acier  
inoxidable AISI 304.  
Cristal transparent.

Lámpara en acero  
inoxidable AISI 304.  
Cristal transparente.

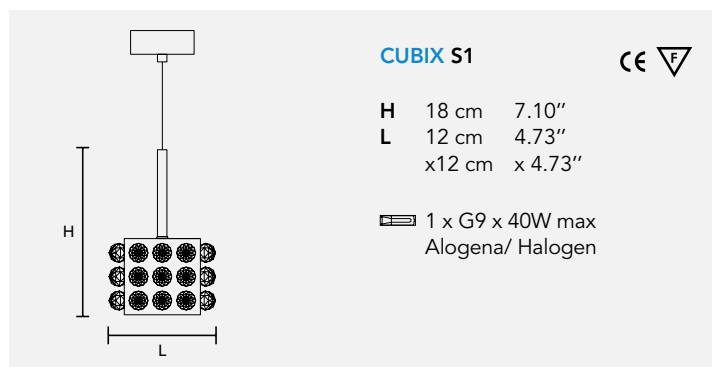
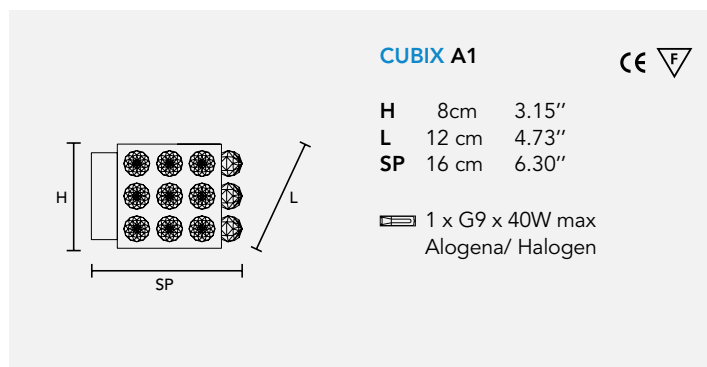
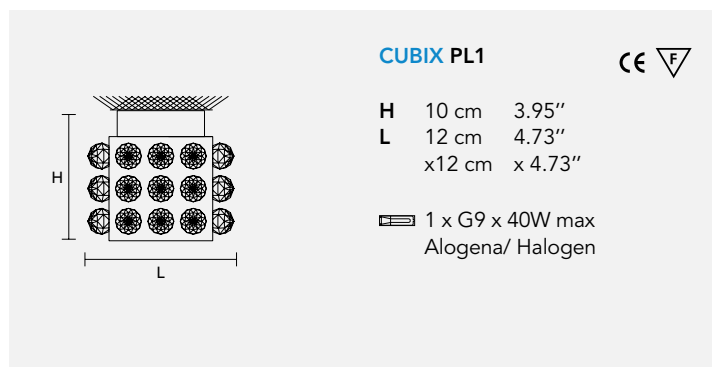



ATTESTA LA CONFORMITÀ DEL PRODOTTO ALLE DISPOSIZIONI DELLE DIRETTIVE COMUNITARIE.

IT CERTIFIES THE CONFORMITY OF THE PRODUCTS TO THE EUROPEAN COMMUNITY PROVISIONS.

IL ATTESTE LA CONFORMITÉ DU PRODUIT AUX DISPOSITIONS DES DIRECTIVES COMMUNITAIRES.

KONFORMITÄ DES PRODUKTES MIT DEN RICHTLINIEN DER EUROPÄISCHEN GEMEINSCHAFT.

ESTA CERTIFICA SI EL PRODUCTO ES CONFORME A LAS DISPOSICIONES DE LAS NORMAS DE LA COMUNIDAD ECONÓMICA EUROPEA.

CLASSE DI ISOLAMENTO CLASSE I. APPARECCHI PROVISTI DI ISOLAMENTO FONDAMENTALE IN OGNI PARTE E CON PARTI CONDUTTRICI ACCESSIBILI COLLEGATE AD UN CONDUTTORE SUPPLEMENTARE DI PROTEZIONE (MESSA A TERRA). DOVE NON SPECIFICATO DIVERSAMENTE, SI INTENDE CLASSE I.

CLASS I. APPLIANCE FITTED WITH BASIC INSULATION THROUGHOUT AND WITH ACCESSIBLE LIVE PARTS CONNECTED TO A SUPPLEMENTARY SAFETY CIRCUIT (GROUND). WHERE NOT EXPRESSLY SPECIFIED, IT IS UNDERSTOOD: CLASS I.

CLASSE I. C'EST-À-DIRE APPAREIL DOTÉ D'ISOLATION FONDAMENTALE DANS TOUTES SES PARTIES ET DONT LES PIÈCES CONDUCTRICES ACCESSIBLES SONT RELIÉES À UN CONDUCTEUR (MISE À LA TERRE). OÙ N'EST PAS EXPRESSÈMENT SPECIFIÉ, ON DOIT S'ENTENDRE: PREMIÈRE CLASSE.

KLASSE I, BZW. AN ALLEN TEILEN ISOLIERTES GERÄT MIT ZUGÄNGLICHENLEITENDEN TEILEN, DIE AN EINEN ZUSÄTZLICHEN SCHUTZLEITER ANGESCHLOSSEN SIND (ERDUNG). WO NICHT ERKLÄRT, VERSTEHT ES SICH: ERSTE KLASSE.

PRIMERA CLASE. ESTO ES APARATO PROVISTO DE AISLAMIENTO FUNDAMENTAL ENTODAS SUS PARTES Y CON PARTES CONDUCTORAS ACCESIBLE, CONEXIONADAS CON CONDUCTOR SUPLEMENTARIO DE PROTECCIÓN (TORNA DE TIERRA). DÓNDE NE ES ESPECIFICADO EXPRESAMENTE SE ENTENDE LA PRIMERA CLASE.



CLASSE DI ISOLAMENTO CLASSE II. CON DOPPIO ISOLAMENTO E/O RINFORZO IN OGNI PARTE E SENZA DISPOSITIVI PER LA MESSA A TERRA.

CLASS OF INSULATIONS CLASS II. APPLIANCE FITTED WITH DOUBLE INSULATION OR REINFORCED INSULATION WITHOUT GROUND CONNECTION.

DEGRÉ LA PROTECTION II. APPAREIL AVEC DOUBLE ISOLATION OU RENFORCE, SANS MISE À LA TERRE. SCHUTZKLASSE II. LEUCHTE MIT DOPPELTER UND/ODER VERSTÄRKTER ISOLIERUNG, OHNE ERDUNG.

CLASE DE AISLAMIENTO CLASE II. CON DOBLE AISLAMIENTO Y/O AISLAMIENTO REFORZADO EN CADA PARTE Y SIN DISPOSITIVO DE TOMA DE TIERRA.



CLASSE DI ISOLAMENTO CLASSE III. APPARECCHI CON PROTEZIONE BASATA SULL'ALIMENTAZIONE A BASSA TENSIONE.

CLASS III. THE SAFETY OF THE FIXTURE IS PROVIDED WITH A LOW-VOLTAGE CIRCUIT DEVICE.

TROISIÈME CLASSE. OU BIEN APPAREIL AVEC PROTECTION BASÉE SUR L'ALIMENTATION À TRÈS BASSE TENSION DE SÉCURITÉ.

DRITTE KLASSE. ODER AUCH GERÄT MIT SCHUTZ, DER AUF EINE SEHR NIEDRIGE SCHUTZSPANNUNGSZUFÜHRUNG GEGRÜNDET IST.

TERCERA CLASE. APARATO CON PRODUCCIÓN SUSTENTADA EN ALIMENTACIÓN A BAJA TENSION DE SEGURIDAD.



APPARECCHIO ADATTO AL MONTAGGIO SU SUPERFICI NORMALMENTE INFIAMMABILI.

SUITABLE FOR MOUNTING ON NONE-FIREPROOF.

APPAREIL PRÉVU POUR UN MONTAGE DIRECT SUR DES SURFACES NORMALEMENT INFLAMMABLES.

KONFORMITÄT DES PRODUKTES MIT DEN RICHTLINIEN DER EUROPÄISCHEN GEMEINSCHAFT. LEUCHTE MIT BRANDSCHULTZ.

APARADO PARA COLOCAR DIRECTAMENTE SOBRE SUPERFICIES INFLAMABLES.

Im

FLUSSO LUMINOSO NOMINALE. L'INDICAZIONE SI RIFERISCE AL VALORE IN ASSENZA DI RIFRAZIONE, COME DICHIARATO DAL PRODUTTORE DEL COMPONENTE.

NOMINAL LUMINOUS FLUX. REFERS TO THE VALUE WITHOUT ANY REFRACTION, AS DECLARED BY THE COMPONENT MANUFACTURER.

L'UNITÉ SI DE FLUX LUMINEUX. L'INDICATION CORRESPONDS À LA VALEUR EN L'ABSENCE DE RÉFRACTION, COMME INDIQUÉ PAR LE FABRICANT DU COMPOSANT.

DIE MASSEINHEIT FÜR DEN LICHTSTROM. DIE ANGABE BEZIEHT SICH AUF DEN WERT IN DER ABWESENHEIT VON BRECHUNG, WIE VOM HERSTELLER DER KOMPONENTE ANGEGEBEN.

FLUJO LUMINOSO NOMINAL. LA INDICACIÓN SE REFIERE AL VALOR EN AUSENCIA DE REFRACCIÓN, COMO DECLARADO POR EL PRODUCTOR DEL COMPONENTE.



THE UL LISTING MARK STANDS FOR TESTED AND EVALUATED PRODUCT TO RECOGNISED US SAFETY STANDARDS. ISSUE NO. M-141,768

MASIERO SI RISERVA IL DIRITTO DI APPORTARE AI PROPRI MODELLI, SENZA NESSUN PREAVVISO, QUALSIASI MODIFICA RITENESSE OPPORTUNA.

MASIERO RESERVES THE RIGHT TO INTRODUCE ANY CHANGES TO ITS OWN MODELS, WITHOUT NOTICE IN ADVANCE.

MASIERO BEHALT SICH DAS RECHT VOR ÄNDERUNGEN VORZUNEHMEN, OHNE SOFORTIGE BENACHRICHTIGUNG.

MASIERO SE RÉSERVE LE DROIT D'APPORTER UNE QUELCONQUE MODIFICATION À LES MODÈLES SANS PRÉAVIS.

MASIERO SE RESERVA EL DERECHO DE REALIZAR CUALQUIER MODIFICACIÓN SOBRE SUS MODELOS SIN PREVIO AVISO.

**MASIERO**®





Masiero disegna e realizza interamente nel proprio opificio lampade eclettiche, dal tradizionale stile veneziano fino al design contemporaneo. L'elemento di continuità è la forte personalità di ogni opera firmata Masiero.

Entirely in his own workshop, Masiero designs and creates lamps of different styles from the traditional Venetian style to contemporary design. The element of continuity is a strong characteristic of every work made by Masiero.

Masiero conçoit et réalise entièrement dans son usine des lampes électriques de styles différents, du style vénitien traditionnel au design contemporain. L'élément de continuité est constitué par la forte personnalité de chaque œuvre signée Masiero.

Masiero diseña y realiza por completo en su propia fábrica lámparas eclécticas, del tradicional estilo veneciano al diseño contemporáneo. El elemento de continuidad es la fuerte personalidad de cada obra firmada Masiero.

Masiero entwirft und konstruiert in ihrem Werk vielseitige Lampen, vom traditionellen venezianischen Stil bis hin zum zeitgemäßen Design. Das kontinuierliche Element besteht in der starken Persönlichkeit jeder einzelnen Kreation von Masiero.





# MASIERO®



**MASIERO S.R.L.** VIA PESCHIERE, 53  
31032 LOC. CONSCIO DI CASALE SUL SILE (TREVISO) ITALY  
TEL. +39 0422 7861 FAX +39 0422 786250

[info@masierogroup.com](mailto:info@masierogroup.com)

[www.masierogroup.com](http://www.masierogroup.com)

Ogni riproduzione anche parziale è vietata.  
© by Masiero 2016  
Tutti i diritti riservati.

Any reproduction even partial is strictly prohibited.  
© by Masiero 2016  
All rights reserved.

Art direction: GIOVANNI BATTISTA GIANOLA

Design by: ARGINE

Copywriter: MARIO MARANGON

Print: GRAFICHE ANTIGA



