



MURANO VENEZIA
ABATEZANETTI

2016

LIGHTING



SOMMARIO
Summary



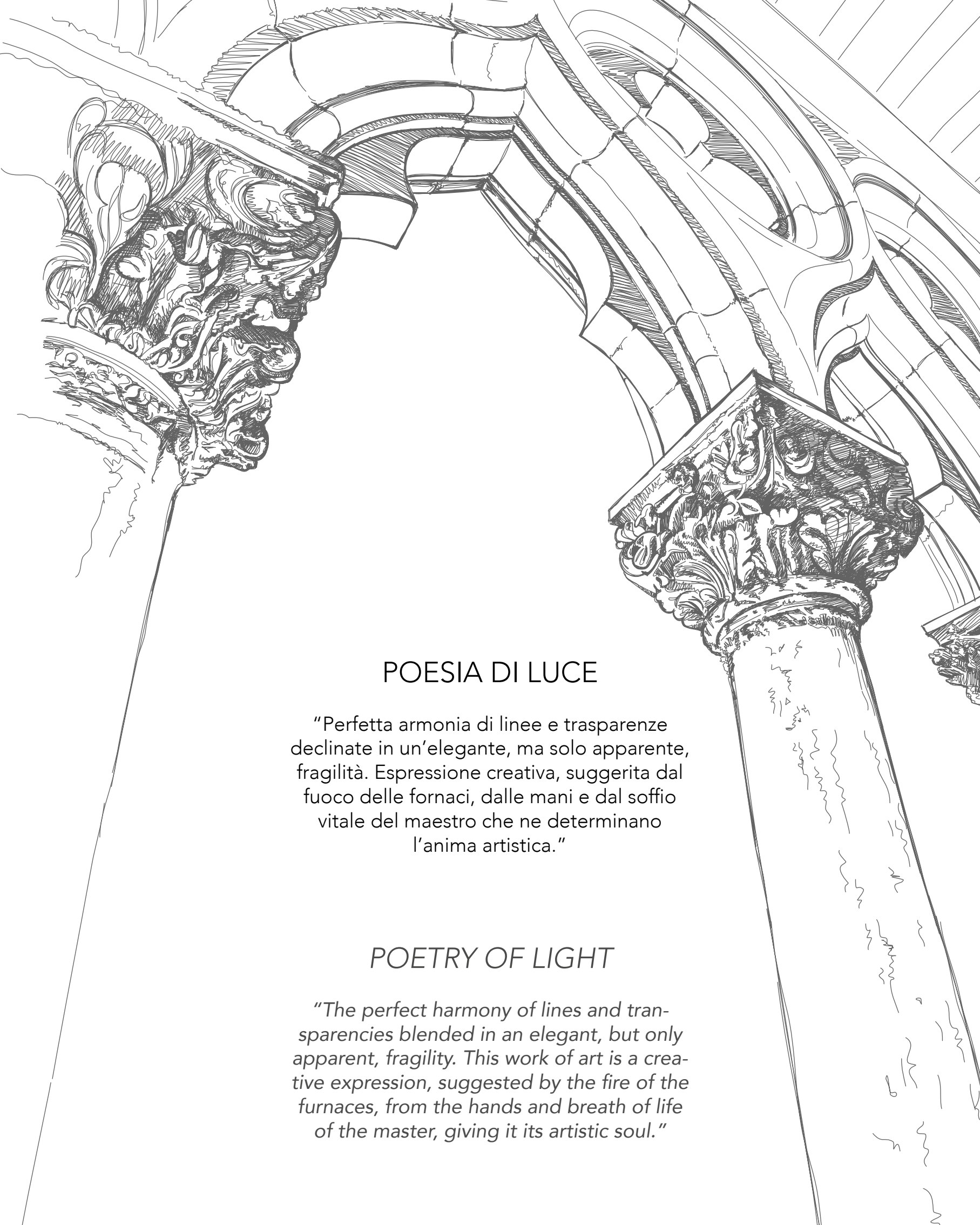

POESIA DI LUCE

"Perfetta armonia di linee e trasparenze declinate in un'elegante, ma solo apparente, fragilità. Espressione creativa, suggerita dal fuoco delle fornaci, dalle mani e dal soffio vitale del maestro che ne determinano l'anima artistica."

POETRY OF LIGHT

"The perfect harmony of lines and transparencies blended in an elegant, but only apparent, fragility. This work of art is a creative expression, suggested by the fire of the furnaces, from the hands and breath of life of the master, giving it its artistic soul."

BALLERINO	16
GORGONE	26
TUNA	34
BOTT	42
BELT	52
MALFATTO	62
SFIORO	72
PARASOL	72
BRISA	73
INNER	82
ERONE	90
JIMMY	98
FORMOSA	108
CAENA	116
SUPERCAENA	128
SAMÌS	136
DAMA ROSSA	144
ALTIÈR	152
CELESTIA	160
CAMOPÌNA	172
FADÀ	180
CONCA	188
CASTELLO	196
REBÉGOLO	208
ARDENTE	220
ACQUARI	232

LI G F I N G 2016





HERITAGE

Fondata nel lontano 1862 dal religioso Vincenzo Zanetti, Abate Zanetti è oggi più che mai il punto d'incontro fra il passato ed il futuro dell'arte del vetro.

Fondée en 1862 par le religieux Vincenzo Zanetti, l'école Abate Zanetti est aujourd'hui plus que jamais le point de rencontre entre le passé et le futur de l'art du verre.

1862年に修道院長Vincenzo ZanettiによりAbate Zanettiは創立されました。現在ではこれまで以上にガラス工芸の過去と未来を結ぶ場所となっています

Founded in 1862 by the cleric Vincenzo Zanetti, Abate Zanetti is today more than ever the meeting point between the past and the future of art glass.

Fundada no longínquo ano de 1862 pelo religioso Vincenzo Zanetti, Abate Zanetti hoje é mais do que nunca o ponto de encontro entre o passado e o futuro da arte do vidro.

由神甫Vincenzo Zanetti创办于1862年，现今，Abate Zanetti 中心已成为玻璃艺术过去与未来的交汇点

Основанный в далеком 1862 году верующим Винченцо Дзанетти, Abate Zanetti – сегодня более чем когда-либо место встречи прошлого и будущего стеклодувного искусства.

تأسست قديماً منذ عام 1862 من رجل Vincenzo "الدين فينشينزو زانتي Zanetti"، اليوم شركة أباتي زانتي، أصبحت أكثر من أي وقت ماضي نقطة التقابل ما بين ماضي ومستقبل فن الزجاج



VINCENZO ZANETTI

MURANO 1824 - 1883

La Storia

L'Abate Vincenzo Zanetti è una delle personalità grazie alle quali Murano è ancora oggi famosa nel mondo. Fu infatti grazie al suo operato, al suo impegno a favore dell'isola e ai suoi insegnamenti che Murano deve la riscoperta della libertà, della sua dignità e del suo prestigio.

Egli studia il passato, riscopre la grandiosità delle opere prodotte nell'antichità e la fama che da essa derivava, la divulga e trova in essa i motivi per un nuovo sviluppo.

Sostiene e loda gli imprenditori e allo stesso tempo si batte per il miglioramento delle condizioni di vita e di lavoro degli operai.

Nel 1862 apre una Scuola di Disegno per Vetrai, annessa al Museo e, nel 1867, fonda il giornale periodico "La Voce di Murano".

The History

The Abbot Vincenzo Zanetti is one of the personalities thanks to which Murano is still famous in the world. It was thanks to his work, his commitment to the island and his teachings that Murano owes the rediscovery of freedom, and of its dignity and prestige.

He studied the past, rediscovering the grandeur of the works produced in antiquity and the fame that stemmed from it, and found in this grandeur, which he helped make known, the reasons for further development.

He supported and commended the entrepreneurs and at the same time fought for an improvement of the living and working conditions of the island's workers.

In 1862 he opened a Drawing School for Glassworkers, annexed to the Museum and, in 1867, founded a newspaper, "La Voce di Murano" ("The Voice of Murano").

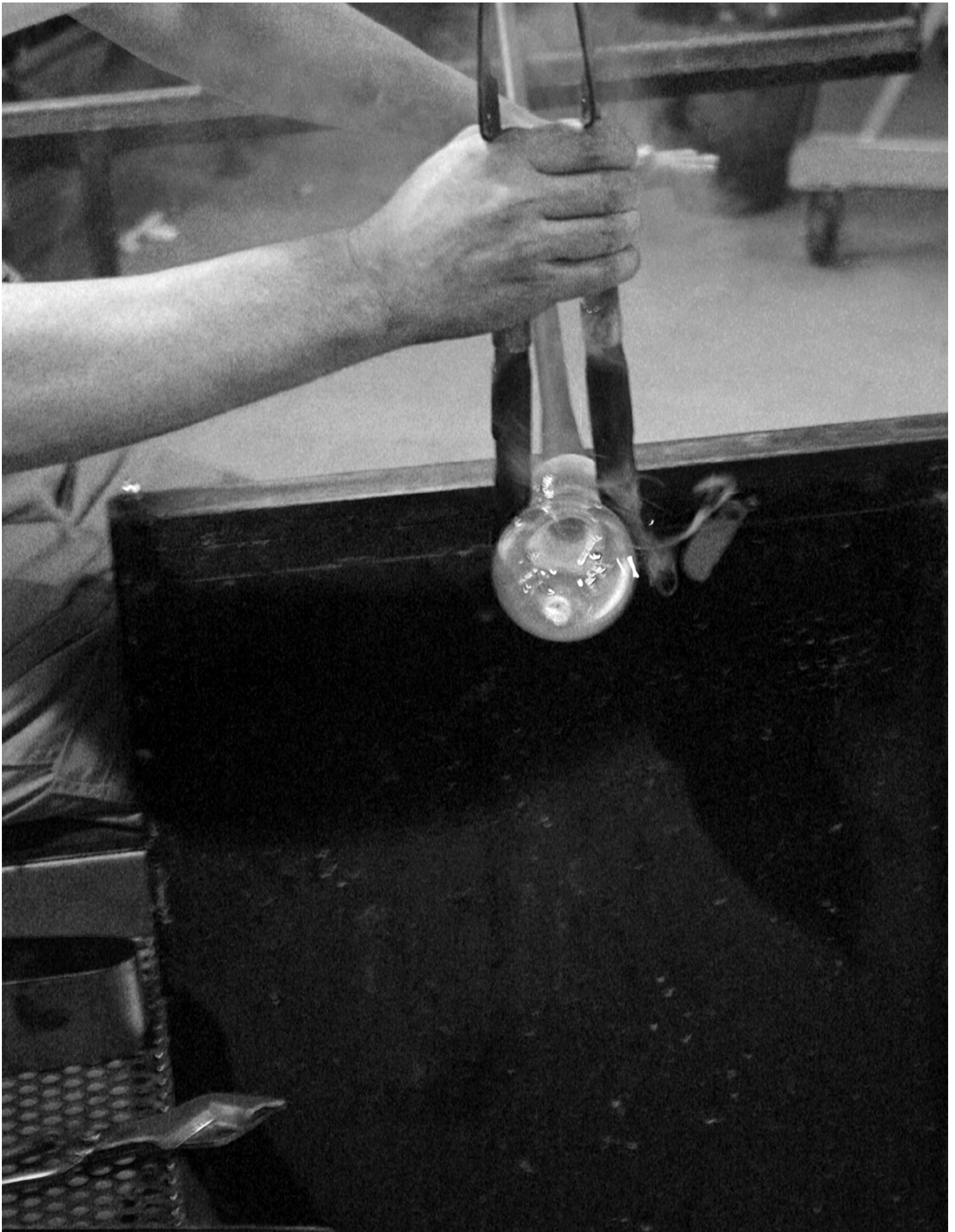

ИСТОРИЯ

Аббат Винченцо Дзанетти – это одна из тех личностей, благодаря которым Мурано известен по всему миру. В самом деле, именно благодаря его работе, его приверженности острову и его обучению, Мурано известен своей свободой, достоинством и престижем.

Он изучал прошлое, открывая заново великолепные произведения, изготовленные в древности, и славу, которую они приносили, распространяя ее и находя в ней мотивы для нового развития.

Он поддерживает и восхваляет предпринимателей и в то же самое время стремится к улучшению условий труда и жизни рабочих.

В 1862 году открывает Школу дизайна для мастеров стекольного дела, присоединенную к музею в 1867 году, основывает периодическую газету «Голос Мурано».

歴史

Vincenzo Zanetti 修道院長は、世界にムラーノ島の名を知らしめている人物の一人です。彼のムラーノ島における業績、尽力とその教育の功績により、この島は自由、尊厳、名声を再発見することができたのです。

彼は過去を研究し、古代のガラス作品のすばらしさとそれがもたらした名声と発展を再びこの世に知らしめ、そこから新たにガラス工芸を発展させる動機を見出しました。

彼は企業家の活動を鼓舞、支持し、同時に職人の仕事と生活条件の向上にも努めました。

1862年に博物館を併設したガラス職人のためのデザイン学校を開校し、1867年には定期情報誌「la Voce di Murano」を発行しました。

L'histoire

L'Abbé Vincenzo Zanetti est une des personnalités grâce à qui Murano est encore célèbre aujourd'hui dans le monde entier. En effet, c'est grâce à ses actions, à son engagement en faveur de l'île et à ses enseignements que Murano doit la redécouverte de sa liberté, de sa dignité et de son prestige.

Il étudie le passé, redécouvre la grandeur des œuvres de l'antiquité et la renommée qui en découlait, la diffuse et trouve en elle les raisons d'un nouveau développement.

Il soutient et loue les entrepreneurs et en même temps se bat pour l'amélioration des conditions de vie et de travail des ouvriers.

En 1862, il ouvre la Scuola di Disegno per Vetrai (école de dessin pour verriers), annexe au Musée et en 1867 il fonde un journal périodique "La Voce di Murano" (La Voie de Murano).

历史

Vincenzo Zanetti 神甫，是为Murano玻璃岛带来今日盛名的关键人物之一。得益于他的工作，他为小岛做出的竭诚努力及其教学活动，Murano才得以重获自由、尊严与声望。

他研究历史，重新发现古老工艺品的伟大及其享有的声誉，并从中发掘发展新动力。

支持与褒扬本地企业家，同时又为改善工人的生活与工作条件持续斗争。

1862年，他开办了玻璃工匠设计学校，作为玻璃工艺博物馆的姐妹机构，1867年，创办期刊“玻璃岛之声”。

A história

O abade Vincenzo Zanetti é uma das personalidades graças às quais Murano ainda hoje é famosa no mundo. Com efeito foi graças à sua atuação, ao seu empenho a favor da ilha e aos seus ensinamentos que Murano redescobriu a liberdade, a sua dignidade e o seu prestígio.

Ele estuda o passado, redescobre a grandiosidade das obras produzidas na antiguidade e a fama que delas derivava, divulga-as e encontra nelas os motivos para um novo desenvolvimento.

Apoia e elogia os empresários e ao mesmo tempo luta pela melhoria das condições de vida e de trabalho dos operários.

Em 1862 abre uma Escola de Design para Vidreiros, anexa ao Museu, e, em 1867, funda um jornal periódico intitulado "La voce di Murano".

التاريخ

إن رئيس الدير فينشينزو زانتي هو أحد الشخصيات الهامة الذي بفضل مازالت مورانو جزيرة شهيرة في العالم. فبالفعل يرجع الفضل لعمله، والتزامه نحو الجزيرة ولتعليمه أن جزيرة مورانو استعادت حريتها، كرامتها ومكانتها.

قام بدراسة الماضي، أعاد اكتشاف عظمة الأعمال الفنية التي أنتجت قديماً والشهرة التي أخذتها، انتشارها ووجد بها دوافع لتطوير جديد.

كان يدعم ويشجع أصحاب الأعمال وفي نفس الوقت يحارب من أجل تحسين ظروف حياة وعمل العمال.

فتح في عام 1862 مدرسة للفنون لحرفيين تصنيع الزجاج، مرفقة بالمتحف، وفي عام 1867 أسس جريدة دورية "la Voce di Murano".



MURANO VENEZIA
ABATEZANETTI
GLASS DESIGN CENTER

MURANO - VENICE
ITALY



THE VENUE

Un superbo edificio di archeologia industriale degli anni Trenta situato nel cuore dell'isola di Murano.

Un superbe bâtiment d'architecture industrielle des années Trente situé au cœur de l'île de Murano.

壮麗な校舎は1930年代の由緒ある工場を改装したもので、ムラーノ島の中心にあります

A superb building of industrial archaeology from the 1930s situated in the heart of the island of Murano.

Um soberbo edifício de arqueologia industrial dos anos trinta situado no coração da ilha de Murano.

位于威尼斯 Murano 玻璃岛中心一座30年代的宏伟的工业建筑大楼

Великолепное здание в индустриальном стиле тридцатых годов, расположенное в самом центре острова Мурано.

مبنى معماري صناعي رائع يرجع إلى الثلاثينات، في قلب جزيرة مورانو



Due sono le anime di Abate Zanetti:

La prima è quella formativa, che trae spunto dalle proprie origini e si esplica attraverso la realizzazione, il coordinamento e la promozione di attività formative ad alto contenuto innovativo.

La seconda anima, in una logica di continuità con la prima, è quella produttiva, un'evoluzione naturale per aprire nuove opportunità in un contesto di mercato che richiede nuove soluzioni.

Abate Zanetti è ora, infatti, anche centro di eccellenza nella produzione, ricerca e sperimentazione sui temi dell'avanguardia artistica e del design del vetro ed è in grado di realizzare opere d'arte in vetro partendo anche dal progetto del committente (con conseguente elaborazione del disegno e del prototipo) o seguendo le indicazioni del designer.

There are two souls of Abate Zanetti:

The first is education, which draws inspiration from its origins and is expressed through the implementation, coordination and promotion of highly innovative training activities.

The second soul, in logic of continuity with the first, is that of production, a natural evolution to open new opportunities in a market environment that requires new solutions.

Abate Zanetti is now, in fact, also a center of excellence in the production, research and experimentation of the themes of artistic avant-garde and glass design and is capable of creating glass works of art starting from a project by the customer (resulting in the elaboration of a design and prototype) or following the instructions of the designer.



У Abate Zanetti две души

Первая – образовательная, которая берет свое начало из старинных традиций, и развивается через реализацию, координацию и продвижение образовательных видов деятельности при высоком инновационном содержании.

Вторая душа – логическое продолжение первой, это производство, естественная эволюция для предложения новых возможностей в контексте рынка, требующего новых решений.

Сегодня Abate Zanetti – это центр совершенствования продукции, исследований и экспериментов в области передовых художественных технологий и дизайна стекла; центр может выполнять художественные произведения из стекла, начиная от разработки проекта заказчика с последующей разработкой рисунков и прототипа, в соответствии с инструкциями дизайнера.

Abate Zanetti の精神はふたつあります。

まず、個人のルーツを引き出し、それをきっかけにした作品の実現を通して自己表現ができるような人材の育成、そして、革新的な質の高い内容の教育活動の推進とコーディネートです。

もう一つの精神は、最初の精神を理論的に継承する生産性です。新しいソリューションを要求する市場において、新たな機会を獲得するための生産性は当然のものだからです。

Abate Zanettiは、前衛的なアートをテーマとした制作、研究、実験とガラスデザインに関する優れたセンターであり、制作依頼者のプロジェクト（デザインと試作品を後に修正するもの）や、デザイナーの指示に従って、ガラスアートの作品を実現することができます。

Abate Zanetti a deux âmes:

La première est l'âme formatrice, qui s'inspire de ses origines et s'exprime à travers la réalisation, la coordination et la promotion d'activités de formations au contenu élevé et innovant.

La seconde âme, dans une logique de continuité avec la première, est l'âme de production, une évolution naturelle pour développer de nouvelles opportunités dans un marché qui demande de nouvelles solutions.

En effet, Abate Zanetti est également aujourd'hui un centre d'excellence dans la production, la recherche et l'expérimentation sur les thèmes de l'avant-garde artistique et du design du verre et est en mesure de réaliser des œuvres d'art en verre en partant du projet du commanditaire (avec élaboration du dessin et du prototype) ou en suivant les indications du designer.

Abate Zanetti 的精神有两个：

首先是教学，从自身传统中汲取灵感，组织、协调与推广高水平内容创新的培训课程。

第二个精神为第一点的延伸，也就是生产，一个在日新月异的市场中开启新机的自然发展过程。

现今，Abate Zanetti 也是一个关于前卫艺术与玻璃设计的优秀生产、研究与实验中心，并可以根据委托方的项目设计（对草稿与原型进行进一步修改）或根据设计师的指示，完成玻璃作品。

Duas são as almas de Abate Zanetti:

A primeira é a formativa, que se inspira nas suas próprias origens e se concretiza na realização, coordenação e promoção de atividades formativas de alto conteúdo inovador.

A segunda alma, numa lógica de continuidade com a primeira, é a produtiva, sendo uma evolução natural para abrir novas oportunidades num contexto de mercado que demanda novas soluções.

Hoje Abate Zanetti também é, de facto, o centro de excelência na produção, investigação e experimentação sobre os temas da vanguarda artística e do design do vidro e é capaz de realizar obras de arte de vidro partindo inclusivamente do projeto do cliente (com a conseguinte elaboração do design e do protótipo) ou segundo as indicações do designer.

تتميز أباتي زانتي بروحين

الأول هو الروح التشكيلي، الذي ألهمت من أصولها ويتم التعبير عنها من خلال أعمال، تنظيم وترويج الأنشطة التدريبية ذات المحتوى المتميز بالابتكار

الثاني، في رابط منطقي مستمر مع الروح الأول، وهي روح الإنتاج، تطور طبيعي لفتح آفاق جديدة في سوق يتطلب حلول جديدة.

أصبحت بالفعل أباتي زانتي اليوم، مركز متميز أيضاً في مجال الإنتاج، البحث والتجربة حول الموضوعات الحديثة الفنية والخاصة بتصميم الزجاج وهو قادر على تنفيذ أعمال فنية زجاجية بدءاً أيضاً من تصميم العميل (وعمل تصميم ونموذج أولي) أو تتبع تعليمات المصمم.







LIGHTING DESIGN

BALLERINO

Design Nigel Coates









BALLERINO
Fam. 3004

Photo: 90 Mirrored Glass Chandelier
with 9 E14 socket bulb
Ø 680 mm H 817 mm
Art. TF 3004 CH / MIR / BRONZE





Ballerino si caratterizza per la dose di energia e dinamismo che trasmette, non solo grazie ai bagliori del vetro specchiato con cui è realizzato, ma anche in virtù della disposizione dei bracci che sembrano ondeggiare, chiudersi e dischiudersi al ritmo composto di una danza.

Ballerino is characterized by the amount of energy and dynamism that it transmits, not only for the flashes of mirrored glass which it is made of, but also for the provision of the arms that appear to sway, to close in and and unfold to the composed rhythm of a dance.





Fam. 3004

BALLERINO

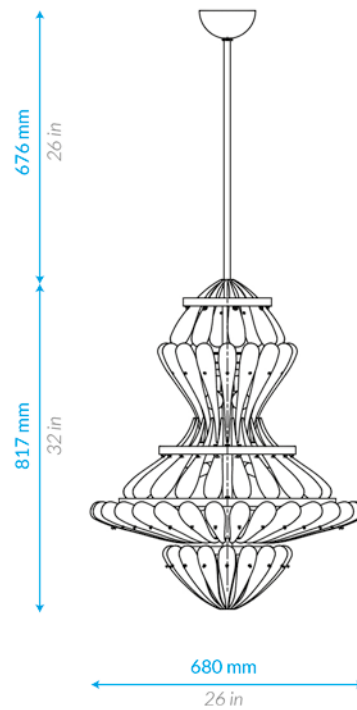

Lampadario 90 Vetri Specchiati
90 Mirrored Glass Chandelier

Item: **TF 3004 CH / MIR**

Light Source: **9 E14 socket bulbs**

Power: **9 x MAX 60 W** (9 HSG P45 46W supplied)

Voltage: **220 / 240 V** (110V Vers. USA)

Product Weight: **20 Kg / lbs 40**

Disponibile in / Available in:

Colore Vetri / Glass Color

Trasparenti / Clear

CR	1	Cristallo Crystal	MA	7	Ametista Medio Medium Amethyst
MT	2	Topazio Medio Medium Topaz	DG	8	Grigio Grey
GG	3	Verde Erba Medio Medium Grass Green	CB	9	Blu Cobalto Cobalt Blue
MG	4	Verde Marino Chiaro Medium Marine Green	BL	10	Nero Black
DE	5	Verde Smeraldo Scuro Dark Emerald Green	MR	11	Rosso Medio Medium Red
DS	6	Acquamarina Scura Dark Sea Water			

Non Trasparenti / Solid

WM	12	Bianco White Milk	LG	18	Grigio Chiaro Light Grey
LG	13	Verde Pisello Light Green	IV	19	Avorio Ivory
NG	14	Verde Nilo Nile Green	PG	20	Grigio Perla Pearl Grey
BP	15	Pervinca Periwinkle	PP	21	Viola Purple
CS	16	Celeste Chiaro Clear Sky	PR	22	Rosso Porpora Chiaro Purple Red
DT	17	Turchese Scuro Dark Turquoise	DB	23	Marrone Scuro Dark Brown

Speciali / Special

LT GREY	29	Grigio Fumè Chiaro Smokey Light Grey	ST	35	Acciaio Trasp. Transp. Steel
DK GREY	30	Grigio Fumè Scuro Smokey Dark Grey	COR	36	Corniola Trasp. Transp. Carnelian
YEL	31	Giallo Limone Lemonish Yellow	AQUA	37	Acquamarina Trasp. Transp. Sea Water
VIOL	32	Violetto Violet	MC	38	Cristallo Specchiato Mirrored Crystal
GREY	33	Grigio Medio Medium Grey	GREEN	39	Verde Green
AM	34	Ametista Trasp. Transp. Amethyst			

Finiture / Finishing

A	Oro Lucido Glossy Gold Plated	G	Nero Opaco Matt Black RAL 9005
B	Cromo Lucido Glossy Chrome Plated	I	Bianco Opaco+Gomma Soft Matt White+Soft Rubber
C	Grigio Opaco Matt Grey RAL 7030	L	Ottone Brunito Burnished Brass
D	Beige Opaco Matt Beige RAL 1019	M	Acciaio Brunito Burnished Steel
E	Marrone Opaco Matt Brown RAL 8028	N	Bianco Verniciato White Painted
F	Bianco Opaco Matt White RAL 9003	O	Verniciatura Bronzo Bronze Painted

Lavorazioni / Techniques

PUL	PULEGOSO	RIG	RIGADIN
BAL	BALLOTON	SPIR	SPIRALE

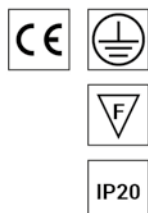

GORGONE

Design Vanessa Vivian





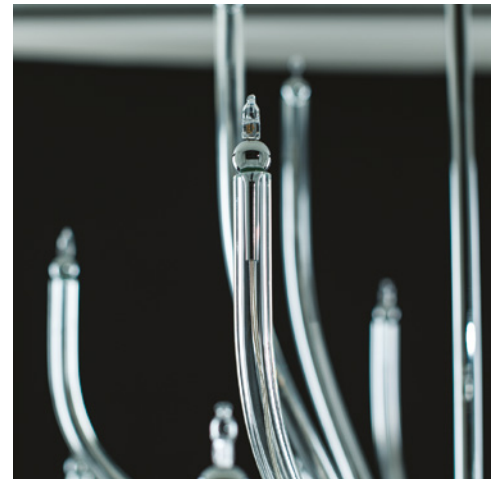

"Gorgone" si ispira al mito della bellezza di Medusa, una delle tre Gorgoni, e alla sua folta chioma di serpenti. Il lampadario riprende e purifica il modello dello chandelier classico. Dal vaso centrale, in vetro bianco, si evolvono in linee sinuose i bracci che terminano verso l'alto. Il lampadario è interamente soffiato a bocca in cristallo trasparente. Il prodotto finale è un oggetto scintillante, dotato di vitale spontaneità.

Gorgone is inspired by the myth of the beauty of Medusa, one of three Gorgon sisters, and by her thick hair of serpents. The chandelier resumes and purifies the classical chandelier model. From the central vase, in white glass, the arms evolve in sinuous lines pointing to the top. The chandelier is entirely blown with crystal glass. The final product is a shining object, that seems to be alive.



GORGONE
Fam. 1023

Photo: 30 Arms Chandelier
Crystal Glass / Glossy Chrome Plated
with 30 halogen lamps
Ø 1100 mm H 875 mm
Art. TF 1023 CH / 30 / CR / CHROM





Fam. 1023

GORGONE

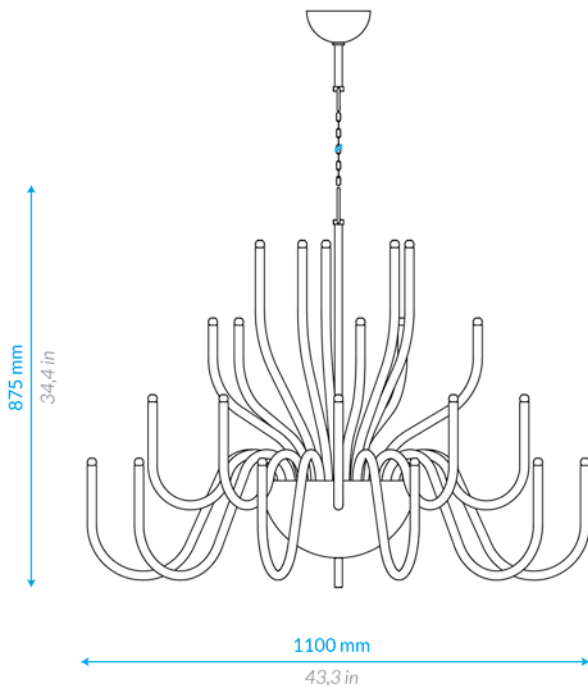

Lampadario 30 Bracci
30 Arms Chandelier

Item: **TF 1023 CH / 30**
Light Source: **G4 Socket halogen bulb**
Power: **30x MAX 10 W**
Voltage: **220 / 240 V** (110V Vers. USA)
Product Weight: **≈ 18 Kg / 39 lbs**

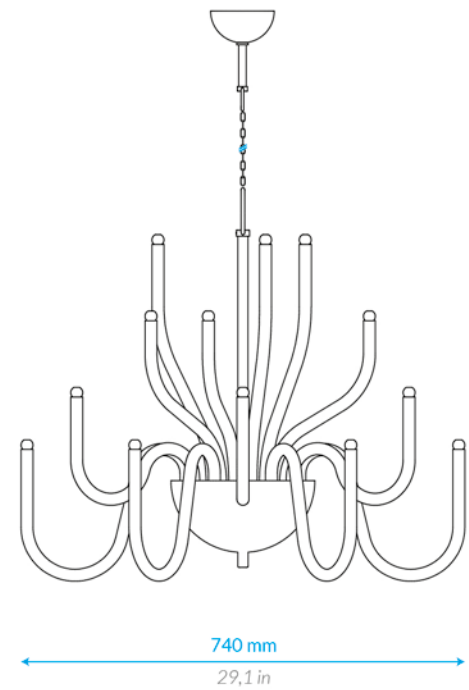

Lampadario 18 Bracci
18 Arms Chandelier

Item: **TF 1023 CH / 18**
Light Source: **G4 Socket halogen bulb**
Power: **18x MAX 10 W**
Voltage: **220 / 240 V** (110V Vers. USA)
Product Weight: **≈ 14 Kg / 30 lbs**



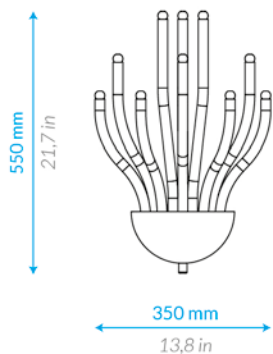

Applique 10 Luci 10 Lights Wall Lamp

Item: **TF 1023 WS / 10**

Light Source: **G4 Socket halogen bulb**

Power: **10x MAX 10 W**

Voltage: **220 / 240 V** (110V Vers. USA)

Product Weight: **≈ 8 Kg / 17 lbs**



Disponibile in / Available in:

Colore Vetri / Glass Color

Trasparenti / Clear

CR	1	Cristallo Crystal	MA	7	Ametista Medio Medium Amethyst
MT	2	Topazio Medio Medium Topaz	DG	8	Grigio Grey
GG	3	Verde Erba Medio Medium Grass Green	CB	9	Blu Cobalto Cobalt Blue
MG	4	Verde Marino Chiaro Medium Marine Green	BL	10	Nero Black
DE	5	Verde Smeraldo Scuro Dark Emerald Green	MR	11	Rosso Medio Medium Red
DS	6	Acquamarina Scura Dark Sea Water			

Non Trasparenti / Solid

WM	12	Bianco White Milk	LG	18	Grigio Chiaro Light Grey
LG	13	Verde Pisello Light Green	IV	19	Avorio Ivory
NG	14	Verde Nilo Nile Green	PG	20	Grigio Perla Pearl Grey
BP	15	Pervinca Periwinkle	PP	21	Viola Purple
CS	16	Celeste Chiaro Clear Sky	PR	22	Rosso Porpora Chiaro Purple Red
DT	17	Turchese Scuro Dark Turquoise	DB	23	Marrone Scuro Dark Brown

Speciali / Special

LT GREY	29	Grigio Fumè Chiaro Smokey Light Grey	ST	35	Acciaio Trasp. Transp. Steel
DK GREY	30	Grigio Fumè Scuro Smokey Dark Grey	COR	36	Corniola Trasp. Transp. Carnelian
YEL	31	Giallo Limone Lemonish Yellow	AQUA	37	Acquamarina Trasp. Transp. Sea Water
VIOL	32	Violetto Violet	MC	38	Cristallo Specchiato Mirrored Crystal
GREY	33	Grigio Medio Medium Grey	GREEN	39	Verde Green
AM	34	Ametista Trasp. Transp. Amethyst			

Finiture /Finishing

A	Oro Lucido Glossy Gold Plated	G	Nero Opaco Matt Black RAL 9005
B	Cromo Lucido Glossy Chrome Plated	I	Bianco Opaco+Gomma Soft Matt White+Soft Rubber
C	Grigio Opaco Matt Grey RAL 7030	L	Ottone Brunito Burnished Brass
D	Beige Opaco Matt Beige RAL 1019	M	Acciaio Brunito Burnished Steel
E	Marrone Opaco Matt Brown RAL 8028	N	Bianco Verniciato White Painted
F	Bianco Opaco Matt White RAL 9003	O	Verniciatura Bronzo Bronze Painted

Lavorazioni /Techniques

PUL	PULEGOSO	RIG	RIGADIN
BAL	BALLOTON	SPIR	SPIRALE

TUNA

Design Chiamonte Marin





MURANO VENEZIA
ABATEZANETTI



Balloton



Pulegoso



Rigadin

Le sospensioni Tuna nascono dall'idea di rappresentare, attraverso la sua stilizzazione, la forma di un pesce che viene ottenuta dalla soffiatura a bocca del vetro trasparente in quattro diverse colorazioni caratterizzate dalle tipiche lavorazioni insulari quali il balloton, il pulegoso e rigadin.

The suspension lamps Tuna are born from the idea to represent, through its abstraction, the shape of a fish obtained by the blowing of transparent glass in four different colours distinguished by the typical Murano craftmanships such as the "balloton", the "pulegoso" and "rigadin".



TUNA
Fam. 1019

Photo: Lighting Suspension
Amethyst Glass / Rigadin
with Led modules
L 1070 mm Ø 110 mm
Art. TF 1019 SU1 / L / AM / RIG



Questa sospensione l'abbiamo immaginata come una sorta di scultura luminosa modulare in quanto può vivere sia come singolo elemento che attraverso composizioni multiple ad evocare banchi di pesci più o meno numerosi.

We imagined this lamp like a kind of modular sculpture of light, because it can live as a single element such as in multiple compositions which evoke wider or narrow schools of fish.



TUNA

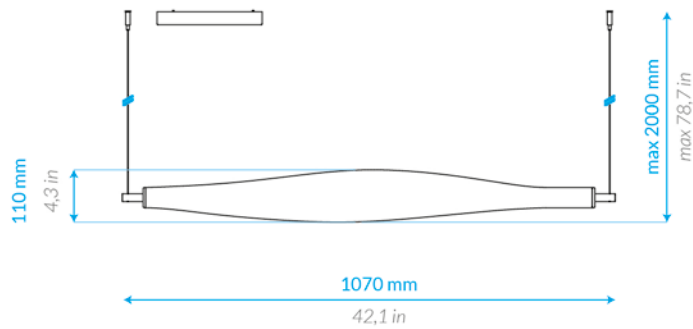

Sospensione Luminosa *Lighting Suspension*

Item: **TF 1019 SU1/L**
Light Source: **LED modules**
Power: **8,4 W**
Voltage: **220 / 240 V** (110V Vers. USA)
Product Weight: **4 Kg / 8 lbs**

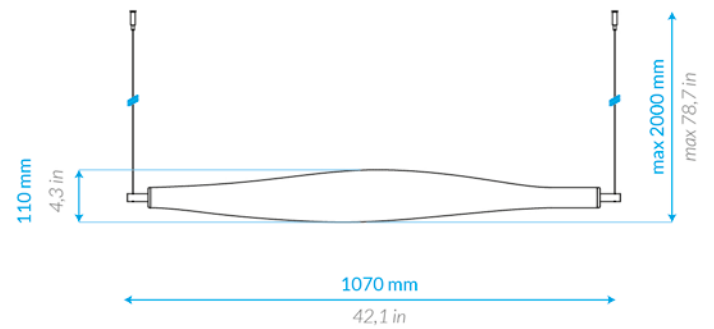
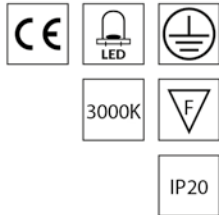

Sospensione Non Luminosa *No Lighting Suspension*

Item: **TF 1019 SU2**
Product Weight: **4 Kg / 8 lbs**



Disponibile in / Available in:

Colore Vetri / Glass Color

Trasparenti / Clear

CR	1	Cristallo Crystal	MA	7	Ametista Medio Medium Amethyst
MT	2	Topazio Medio Medium Topaz	DG	8	Grigio Grey
GG	3	Verde Erba Medio Medium Grass Green	CB	9	Blu Cobalto Cobalt Blue
MG	4	Verde Marino Chiaro Medium Marine Green	BL	10	Nero Black
DE	5	Verde Smeraldo Scuro Dark Emerald Green	MR	11	Rosso Medio Medium Red
DS	6	Acquamarina Scura Dark Sea Water			

Non Trasparenti / Solid

WM	12	Bianco White Milk	LG	18	Grigio Chiaro Light Grey
LG	13	Verde Pisello Light Green	IV	19	Avorio Ivory
NG	14	Verde Nilo Nile Green	PG	20	Grigio Perla Pearl Grey
BP	15	Pervinca Periwinkle	PP	21	Viola Purple
CS	16	Celeste Chiaro Clear Sky	PR	22	Rosso Porpora Chiaro Purple Red
DT	17	Turchese Scuro Dark Turquoise	DB	23	Marrone Scuro Dark Brown

Speciali / Special

LT GREY	29	Grigio Fumè Chiaro Smokey Light Grey	ST	35	Acciaio Trasp. Transp. Steel
DK GREY	30	Grigio Fumè Scuro Smokey Dark Grey	COR	36	Corniola Trasp. Transp. Carnelian
YEL	31	Giallo Limone Lemonish Yellow	AQUA	37	Acquamarina Trasp. Transp. Sea Water
VIOL	32	Violetto Violet	MC	38	Cristallo Specchiato Mirrored Crystal
GREY	33	Grigio Medio Medium Grey	GREEN	39	Verde Green
AM	34	Ametista Trasp. Transp. Amethyst			

Finiture / Finishing

A	Oro Lucido Glossy Gold Plated	G	Nero Opaco Matt Black RAL 9005
B	Cromo Lucido Glossy Chrome Plated	I	Bianco Opaco+Gomma Soft Matt White+Soft Rubber
C	Grigio Opaco Matt Grey RAL 7030	L	Ottone Brunito Burnished Brass
D	Beige Opaco Matt Beige RAL 1019	M	Acciaio Brunito Burnished Steel
E	Marrone Opaco Matt Brown RAL 8028	N	Bianco Verniciato White Painted
F	Bianco Opaco Matt White RAL 9003	O	Verniciatura Bronzo Bronze Painted

Lavorazioni / Techniques

PUL	PULEGOSO	RIG	RIGADIN
BAL	BALLOTON	SPIR	SPIRALE

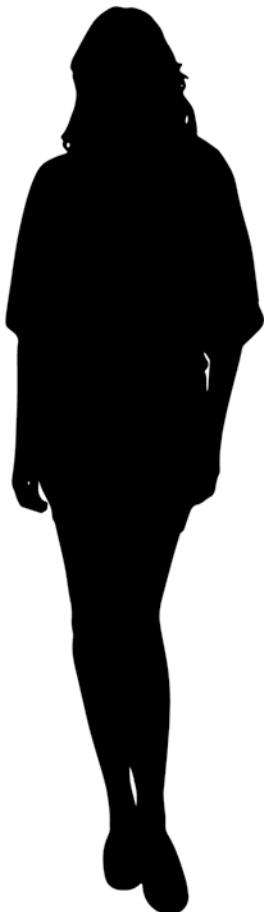

BOTT

Design Chiaramonte Marin





La serie "Bott" nasce dall'idea di lavorare su una lampada dalla forma pura ed essenziale realizzata con un vetro soffiato in tre colorazioni. Abbiamo cercato di enfatizzare la forma slanciata dell'oggetto attraverso l'utilizzo della sfumatura del colore dal basso verso l'alto. Inoltre, attraverso un sistema di bloccaggio invisibile, abbiamo ideato una particolare maniglia che consente un facile spostamento della lampada.

The "Bott" series is born from the idea of working on a lamp with a pure and essential shape, created with blown glass in three different colours. We tried to emphasize the slender shape of the item with the use of a bottom-to-top colour gradient. Through the use of an invisible blocking system, we designed a specific type of handle which provides an easy way of moving the lamp.



BOTT
Fam. 1021

Floor/Table Lamp
White Milk Glass / Burnished Brass
with E27 socket bulb
Ø 270 mm H 850 mm
Art. TF 1021 RL1 / WHITE





BOTT
Fam. 1021

Lighting Suspension
Light Grey Glass / Burnished Steel
with E27 socket bulb
Ø 270 mm H 850 mm
Art. TF 1021 SU1 / LTGREY





BOTT

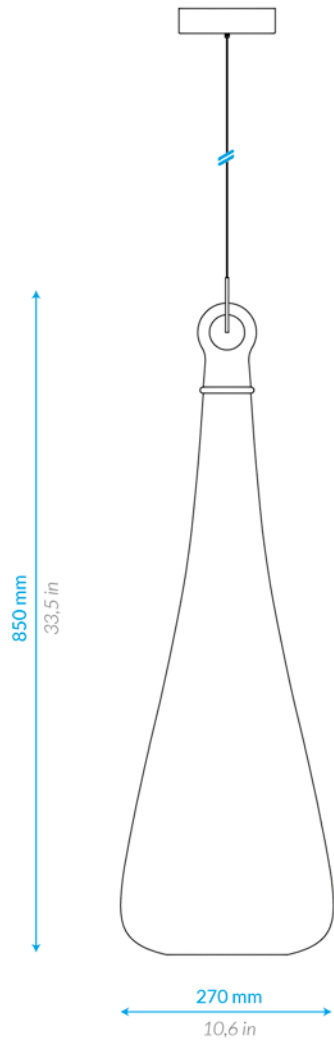

Sospensione Luminosa *Lighting Suspension*

Item: **TF 1021 SU / 1**
Light Source: **E27 Socket bulb**
Power: **MAX 150 W** (HSG A55 116 W supplied dimmable)
Voltage: **220 / 240 V** (110V Vers. USA)
Product Weight: **≈5 Kg / 11 lbs**

Lampada da Terra/Tavolo *Table/Floor Lamp*

Item: **TF 1021 RL/1**
Light Source: **E27 Socket bulb**
Power: **MAX 150 W**
(HSG A55 116 W supplied dimmable)
Voltage: **220 / 240 V** (110V Vers. USA)
Product Weight: **≈5 Kg / 11 lbs**

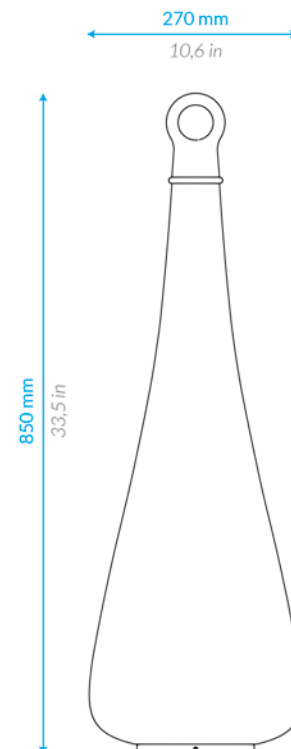



Disponibile in / Available in:

Colore Vetri / Glass Color

Trasparenti / Clear

CR	1	Cristallo Crystal	MA	7	Ametista Medio Medium Amethyst
MT	2	Topazio Medio Medium Topaz	DG	8	Grigio Grey
GG	3	Verde Erba Medio Medium Grass Green	CB	9	Blu Cobalto Cobalt Blue
MG	4	Verde Marino Chiaro Medium Marine Green	BL	10	Nero Black
DE	5	Verde Smeraldo Scuro Dark Emerald Green	MR	11	Rosso Medio Medium Red
DS	6	Acquamarina Scura Dark Sea Water			

Non Trasparenti / Solid

WM	12	Bianco White Milk	LG	18	Grigio Chiaro Light Grey
LG	13	Verde Pisello Light Green	IV	19	Avorio Ivory
NG	14	Verde Nilo Nile Green	PG	20	Grigio Perla Pearl Grey
BP	15	Pervinca Periwinkle	PP	21	Viola Purple
CS	16	Celeste Chiaro Clear Sky	PR	22	Rosso Porpora Chiaro Purple Red
DT	17	Turchese Scuro Dark Turquoise	DB	23	Marrone Scuro Dark Brown

Speciali / Special

LT GREY	29	Grigio Fumè Chiaro Smokey Light Grey	ST	35	Acciaio Trasp. Transp. Steel
DK GREY	30	Grigio Fumè Scuro Smokey Dark Grey	COR	36	Corniola Trasp. Transp. Carnelian
YEL	31	Giallo Limone Lemonish Yellow	AQUA	37	Acquamarina Trasp. Transp. Sea Water
VIOL	32	Violetto Violet	MC	38	Cristallo Specchiato Mirrored Crystal
GREY	33	Grigio Medio Medium Grey	GREEN	39	Verde Green
AM	34	Ametista Trasp. Transp. Amethyst			

Finiture / Finishing

A	Oro Lucido Glossy Gold Plated	G	Nero Opaco Matt Black RAL 9005
B	Cromo Lucido Glossy Chrome Plated	I	Bianco Opaco+Gomma Soft Matt White+Soft Rubber
C	Grigio Opaco Matt Grey RAL 7030	L	Ottone Brunito Burnished Brass
D	Beige Opaco Matt Beige RAL 1019	M	Acciaio Brunito Burnished Steel
E	Marrone Opaco Matt Brown RAL 8028	N	Bianco Verniciato White Painted
F	Bianco Opaco Matt White RAL 9003	O	Verniciatura Bronzo Bronze Painted

Lavorazioni / Techniques

PUL	PULEGOSO	RIG	RIGADIN
BAL	BALLOTON	SPIR	SPIRALE



BELT

Design Chiaramonte Marin





Una cintura formata da vetri sagomati che accostandosi possono creare forme diverse, su più livelli sovrapposti o concentrici. Qui pure il richiamo alla tipica produzione Muranese dei lampadari componibili e customized è evidente, ma coniugato tramite l'utilizzo di vetro sottile ed evanescente, dalla texture morbida e al contempo dal taglio spigoloso e deciso.

A belt composed by shaped glass that may create different forms, on different and concentric layers.

The typical production of modular and customized chandeliers of Murano tradition is evident in this piece, but rendered through the use of thin and evanescent glass, with a soft texture and a sharp and strong cut as well.



BELT
Fam. 1020

Lighting Suspension
Violet Glass / Burnished Steel
with E27 socket bulb
Ø 200 mm H 610 mm
Art. TF 1020 SU / 6 / VIOL





Violet Glass



Medium Grey Glass

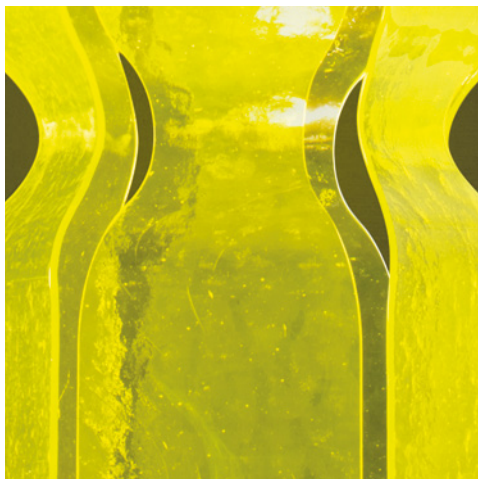

Lemonish Yellow Glass





BELT
Fam. 1020

Lighting Suspension
Lemonish Yellow / Burnished Steel
with E27 socket bulb
L 1790 mm H 610 mm
Art. TF 1020 SU / 38 / YEL

BELT

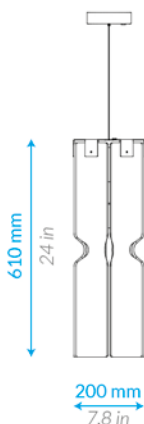

Sospensione Luminosa
Lighting Suspension

Item: **TF 1020 SU / 6**
 Light Source: **E27 Socket bulb**
 Power: **MAX 150 W**
 (HSG A55 77 W Supplied)
 Voltage: **220 / 240 V** (110V Vers. USA)
 Product Weight: **5 Kg / 11 lbs**

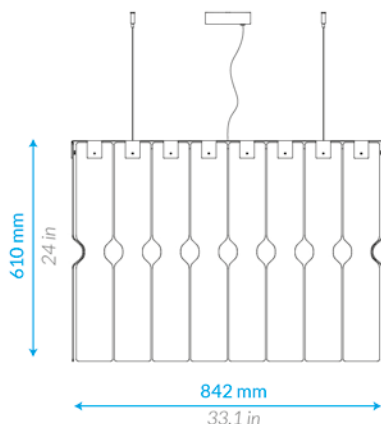

Sospensione Luminosa
Lighting Suspension

Item: **TF 1020 SU / 20**
 Light Source: **E27 Socket bulb**
 Power: **2x MAX 150 W**
 (2 HSG A55 77 W supplied)
 Voltage: **220 / 240 V** (110V Vers. USA)
 Product Weight: **13 Kg / 28 lbs**

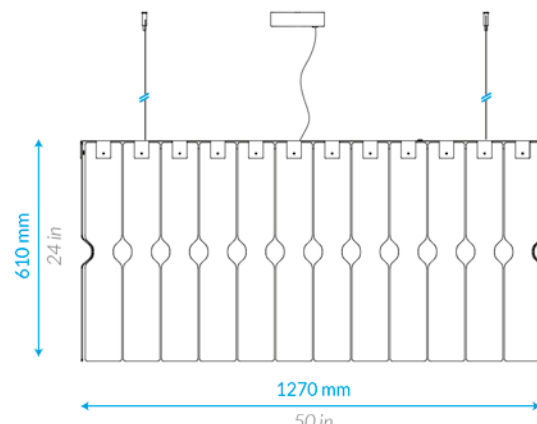

Sospensione Luminosa
Lighting Suspension

Item: **TF 1020 SU / 28**
 Light Source: **E27 Socket bulb**
 Power: **3x MAX 150 W**
 (3 HSG A55 77 W supplied)
 Voltage: **220 / 240 V** (110V Vers. USA)
 Product Weight: **17 Kg / 37 lbs**

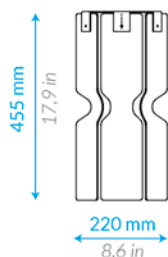

Applique 1 Luce
1 Light Wall Lamp

Item: **TF 1020 WS / 1**
 Light Source: **E27 Socket bulb**
 Power: **MAX 100 W** (HSG A55 77 W supplied)
 Voltage: **220 / 240 V** (110V Vers. USA)
 Product Weight: **3 Kg / 6 lbs**



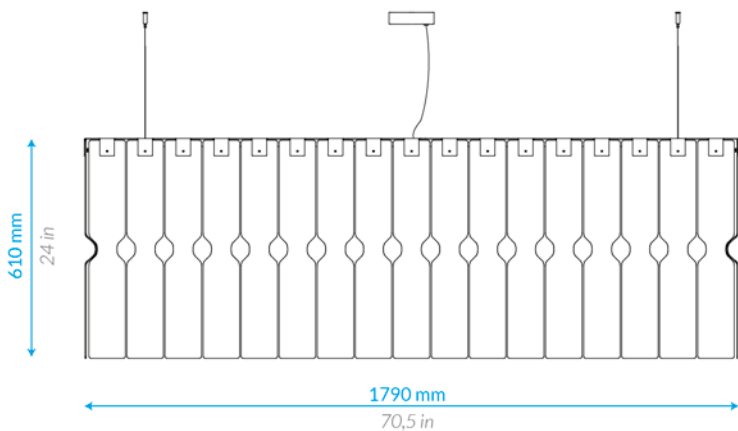

Sospensione Luminosa Lighting Suspension

Item: **TF 1020 SU / 38**

Light Source: **E27 Socket bulb**

Power: **5x MAX 150 W**

(2 HSG A55 77 W)

Voltage: **220 / 240 V** (110V Vers. USA)

Product Weight: **23 Kg / 51 lbs**



Disponibile in / Available in:

Colore Vetri / Glass Color

Trasparenti / Clear

CR	1	Cristallo Crystal	MA	7	Ametista Medio Medium Amethyst
MT	2	Topazio Medio Medium Topaz	DG	8	Grigio Grey
GG	3	Verde Erba Medio Medium Grass Green	CB	9	Blu Cobalto Cobalt Blue
MG	4	Verde Marino Chiaro Medium Marine Green	BL	10	Nero Black
DE	5	Verde Smeraldo Scuro Dark Emerald Green	MR	11	Rosso Medio Medium Red
DS	6	Acquamarina Scura Dark Sea Water			

Non Trasparenti / Solid

WM	12	Bianco White Milk	LG	18	Grigio Chiaro Light Grey
LG	13	Verde Pisello Light Green	IV	19	Avorio Ivory
NG	14	Verde Nilo Nile Green	PG	20	Grigio Perla Pearl Grey
BP	15	Pervinca Periwinkle	PP	21	Viola Purple
CS	16	Celeste Chiaro Clear Sky	PR	22	Rosso Porpora Chiaro Purple Red
DT	17	Turchese Scuro Dark Turquoise	DB	23	Marrone Scuro Dark Brown

Speciali / Special

LT GREY	29	Grigio Fumè Chiaro Smokey Light Grey	ST	35	Acciaio Trasp. Transp. Steel
DK GREY	30	Grigio Fumè Scuro Smokey Dark Grey	COR	36	Corniola Trasp. Transp. Carnelian
YEL	31	Giallo Limone Lemonish Yellow	AQUA	37	Acquamarina Trasp. Transp. Sea Water
VIOL	32	Violetto Violet	MC	38	Cristallo Specchiato Mirrored Crystal
GREY	33	Grigio Medio Medium Grey	GREEN	39	Verde Green
AM	34	Ametista Trasp. Transp. Amethyst			

Finiture / Finishing

A	Oro Lucido Glossy Gold Plated	G	Nero Opaco Matt Black RAL 9005
B	Cromo Lucido Glossy Chrome Plated	I	Bianco Opaco+Gomma Soft Matt White+Soft Rubber
C	Grigio Opaco Matt Grey RAL 7030	L	Ottone Brunito Burnished Brass
D	Beige Opaco Matt Beige RAL 1019	M	Acciaio Brunito Burnished Steel
E	Marrone Opaco Matt Brown RAL 8028	N	Bianco Verniciato White Painted
F	Bianco Opaco Matt White RAL 9003	O	Verniciatura Bronzo Bronze Painted

Lavorazioni / Techniques

PUL	PULEGOSO	RIG	RIGADIN
BAL	BALLOTON	SPIR	SPIRALE

MALFATTO

Design Chiaramonte Marin

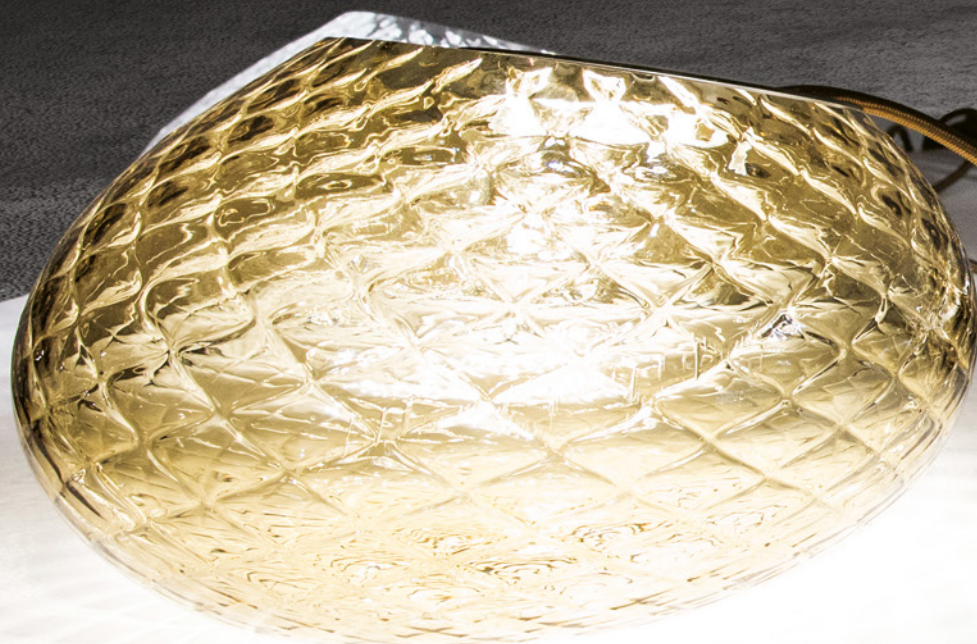





Le lampade da tavolo "Malfatto" nascono dall'idea di creare oggetti luminosi unici e diversi tra loro in quanto liberamente sagomati dal Maestro vetraio sulla traccia di forme da noi disegnate ed ispirate a quelle dei sassi.

Gli elementi in vetro presentano quattro lavorazioni tipiche della tradizione muranese: il balloton, il vetro pulegoso, il rigadin.

La fonte luminosa può, attraverso un originale sistema di calamite, essere rimossa trasformando l'oggetto da lampada in vaso. Una lampada a led è inserita all'interno di un braccio magnetico che, dunque serve da sorgente luminosa e che grazie ad un sistema di tre calamite posto sul bordo dell'elemento in vetro può essere con un solo e semplice gesto posizionato o rimosso, trasformando la lampada in un vaso, un portaoggetti o una scultura.

The table lamps "Malfatto" are born from the idea to create unique luminous objects which are different from each other since they are freely shaped by the glass masters on the trail of forms designed by us , based on those of stones.

The glass elements have four typical processes of the Murano tradition: the balloton, glass pulegoso, the rigadin.

The light source can, through an original system of magnets, be removed by transforming the lamp object in a vase.

An LED lamp is inserted inside a magnetic arm which, therefore, serves as a light source and that thanks to a system of three magnets placed on the rim of the diffuser can be with a simple gesture positioned or removed, transforming the lamp in a vase, a box or a sculpture.



Balloton



Pulegoso



Rigadin



Crystal Glass and white Spiral

MALFATTO

Fam. 1022

Photo: Table Lamp
Crystal Glass / Baloton
with Led module
Ø 230 mm H 135 mm
Art. TF 1022 TL / 1 / CR / BAL



La lavorazione a balloton, consente di dare al vetro l'affascinante effetto di una grafica romboidale, che associata alla fonte luminosa interna dona al vetro una miriade di brillanti sfaccettature. La lavorazione è ottenuta grazie all'ausilio di uno stampo in metallo contenente punte a piramide quadrata.

The processing of balloton, will supply the glass with the fascinating effect of a graphic rhomboid, which associated with the internal light source gives the glass a myriad of brilliant facets. The processing is obtained with the aid of a metal mold containing tips in square pyramid.

MALFATTO

Fam. 1022

Photo: Table Lamp
Crystal Glass / Pulegoso
with Led module
Ø 230 mm H 135 mm
Art. TF 1022 TL / 1 / CR / PUL

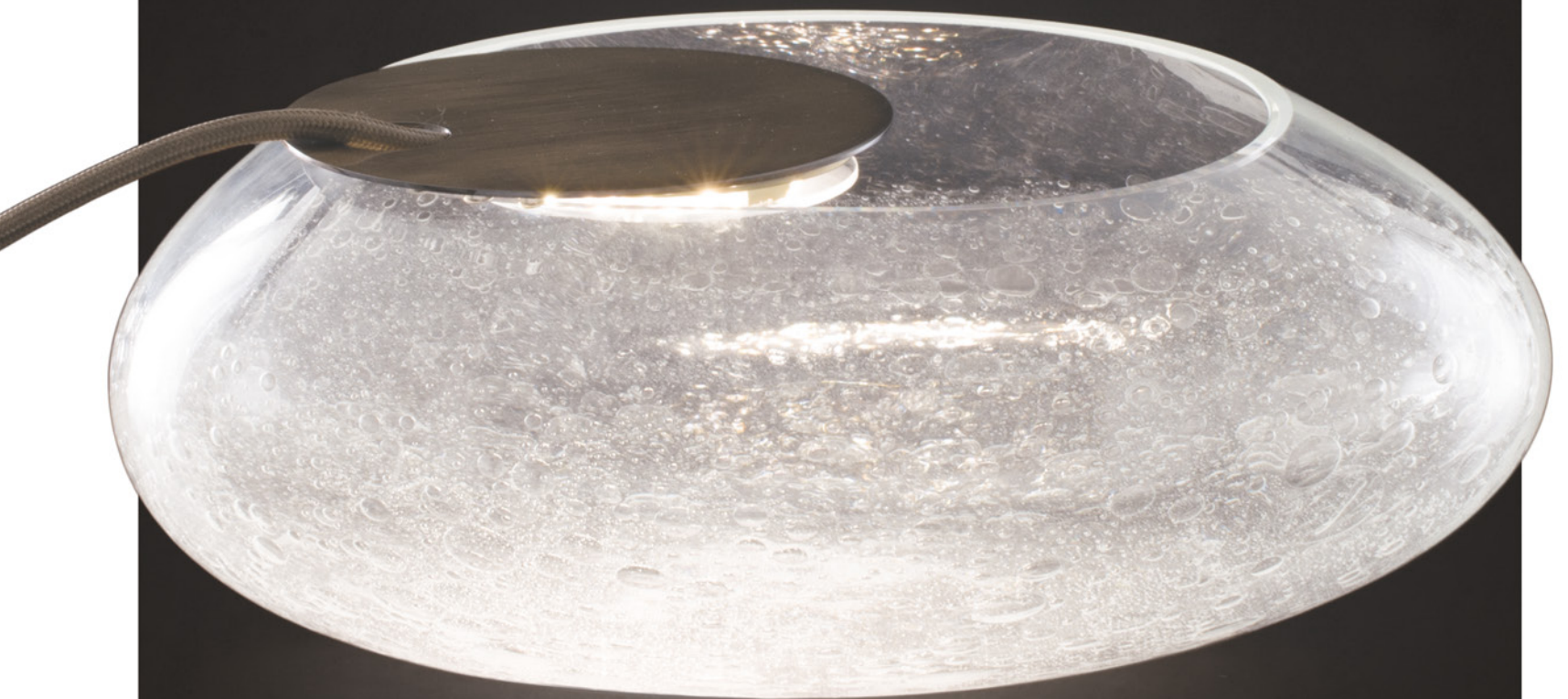

Il vetro pulegoso è un materiale estremamente particolare, denso ed espressivo. Le bollicine d'aria fitte e irregolari che lo animano riescono perfettamente a comunicare l'idea che il vetro sia figlio dei quattro elementi fondamentali, aria-acqua-terra-fuoco. Pensare che nel corso dei secoli moltissimi vetrai erano andati alla ricerca del metodo per eliminare quelle pulighe (appunto le bolle) che offuscavano la trasparenza del vetro.

The pulegoso glass is extremely special, dense and expressive. The irregular and dense air bubbles that are perfectly animated are able to communicate the idea that glass is the son of the four basic elements, air, water, earth, and fire. To think that over the centuries many glassmakers have gone in search of a way to eliminate those pulighe (the bubbles) that clouded the transparency of glass.

MALFATTO

Fam. 1022

Photo: Table Lamp
Crystal Glass / Rigadin
with Led module
Ø 230 mm H 135 mm
Art. TF 1022 TL / 1 / CR / RIG



La lavorazione a rigadin si ottiene soffiando il bolo in vetro in uno stampo di bronzo, recante delle scanalature triangolari, in questo modo al vetro si può conferire qualsiasi forma, e donargli una particolare ed elegante forma a spirale.

The processing of rigadin is obtained by blowing the glass into a mold of bronze, bearing some triangular grooves, this way the glass can confer any form, and gives it a particular and elegant spiral shape.

MALFATTO

Fam. 1022

Photo: Table Lamp
Crystal Glass / Spiral
with Led module

Ø 230 mm H 135 mm

Art. TF 1022 TL / 1 / CR / SPIR







Fam. 1022

MALFATTO

Lampada da Tavolo *Table Lamp*

Item: **TF 1022 TL / 1**
Light Source: **LED module**
Power: **8,4 W**
Voltage: **220 / 240 V** (110V Vers. USA)
Product Weight: **≈3,5 Kg / 7 lbs**

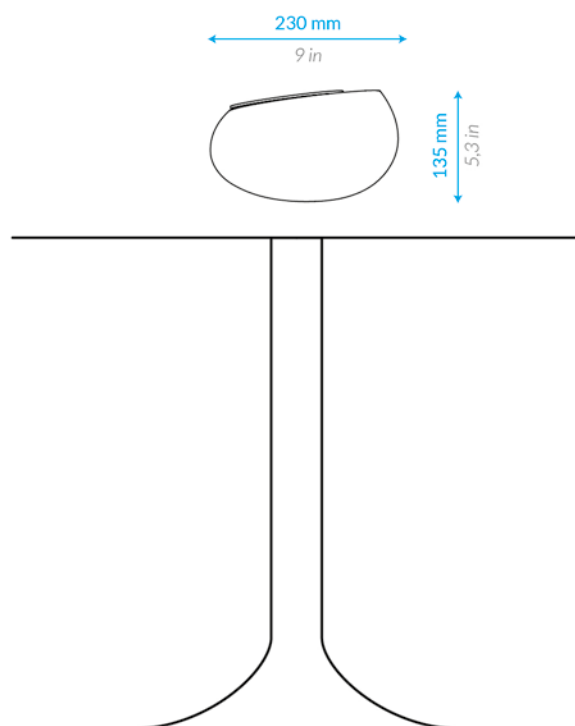

Disponibile in / Available in:

Colore Vetri / Glass Color

Trasparenti / Clear

CR	1	Cristallo Crystal	MA	7	Ametista Medio Medium Amethyst
MT	2	Topazio Medio Medium Topaz	DG	8	Grigio Grey
GG	3	Verde Erba Medio Medium Grass Green	CB	9	Blu Cobalto Cobalt Blue
MG	4	Verde Marino Chiaro Medium Marine Green	BL	10	Nero Black
DE	5	Verde Smeraldo Scuro Dark Emerald Green	MR	11	Rosso Medio Medium Red
DS	6	Acquamarina Scura Dark Sea Water			

Non Trasparenti / Solid

WM	12	Bianco White Milk	LG	18	Grigio Chiaro Light Grey
LG	13	Verde Pisello Light Green	IV	19	Avorio Ivory
NG	14	Verde Nilo Nile Green	PG	20	Grigio Perla Pearl Grey
BP	15	Pervinca Periwinkle	PP	21	Viola Purple
CS	16	Celeste Chiaro Clear Sky	PR	22	Rosso Porpora Chiaro Purple Red
DT	17	Turchese Scuro Dark Turquoise	DB	23	Marrone Scuro Dark Brown

Speciali / Special

LT GREY	29	Grigio Fumè Chiaro Smokey Light Grey	ST	35	Acciaio Trasp. Transp. Steel
DK GREY	30	Grigio Fumè Scuro Smokey Dark Grey	COR	36	Corniola Trasp. Transp. Carnelian
YEL	31	Giallo Limone Lemonish Yellow	AQUA	37	Acquamarina Trasp. Transp. Sea Water
VIOL	32	Violetto Violet	MC	38	Cristallo Specchiato Mirrored Crystal
GREY	33	Grigio Medio Medium Grey	GREEN	39	Verde Green
AM	34	Ametista Trasp. Transp. Amethyst			

Finiture / Finishing

A	Oro Lucido Glossy Gold Plated	G	Nero Opaco Matt Black RAL 9005
B	Cromo Lucido Glossy Chrome Plated	I	Bianco Opaco+Gomma Soft Matt White+Soft Rubber
C	Grigio Opaco Matt Grey RAL 7030	L	Ottone Brunito Burnished Brass
D	Beige Opaco Matt Beige RAL 1019	M	Acciaio Brunito Burnished Steel
E	Marrone Opaco Matt Brown RAL 8028	N	Bianco Verniciato White Painted
F	Bianco Opaco Matt White RAL 9003	O	Verniciatura Bronzo Bronze Painted

Lavorazioni / Techniques

PUL	PULEGOSO	RIG	RIGADIN
BAL	BALLOTON	SPIR	SPIRALE

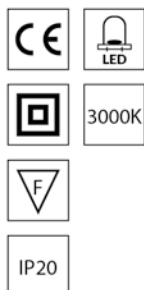

PARASOL

SFIORO





BRISA

Design by Luigi Brugnaro

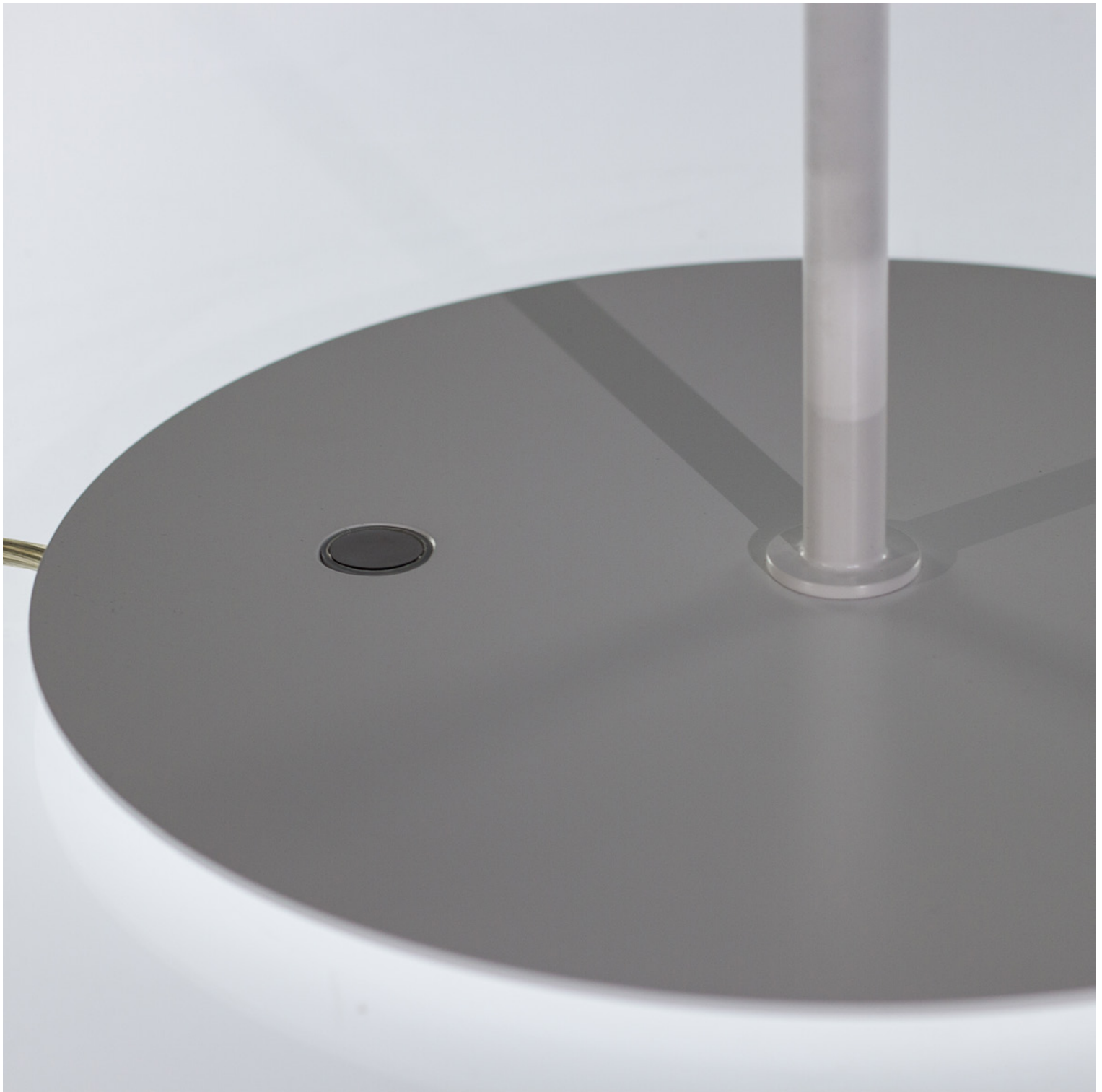

La lampada da tavolo "Sfioro" unisce al suo interno tradizione e innovazione, infatti combina la classica forma della lampada a paralume, rivisitata in forme minimali, con la tecnologia a sfioramento che la caratterizza. Toccando il bottone alla base della lampada sarà possibile utilizzare la funzione di accensione o spegnimento, mentre con lo sfioramento sarà possibile regolare la luminosità.

The table lamp "Sfioro" unites in a single item tradition and innovation, it combines the classic shape of a lampshade, redesigned in minimal lines, with touch-control technology that defines it. Touching the control at the base of the lamp you can light it on or off, or manage the luminosity level.



SFIORO
Fam. 1024

Photo: Table Lamp
White Milk Glass / White Painted
with E14 socket bulbs
Ø 500 mm H 530 mm
Art. TF 1024 TL / 2 / WM / WHITE



La lampada "Parasol" mescola serietà funzionale e leggerezza formale. In Parasol la larga base circolare va gradualmente a rastremarsi verso l'alto e riesplodere in una florida semisfera. La combinazione tra questi elementi fa sì che l'oggetto acquisisca un'aura vivace, divertente e originale.

Abate Zanetti con questa lampada, totalmente realizzata in vetro bianco soffiato a bocca, riesce nel contempo a rinfrescare un materiale antico quale il vetro e ad elevare il linguaggio pop del disegno.

The "Parasol" lamp mixes functional seriousness and formal lightness. In "Parasol" the wide circular base gradually shrinks to the top and explodes in a flourishing hemisphere. The combination of these elements makes it possible for the lamp to acquire a lively, fun and original aura.

Abate Zanetti with this lamp, entirely created in blown white glass, is able to refresh and ancient material such is glass and elevates the pop language of its design.



PARASOL
Fam. 1024

Photo: Table Lamp
White Milk Glass / White Painted
with E14 socket bulbs
Ø 500 mm H 550 mm
Art. TF 1024 TL / 1 / WM / WHITE



La lampada da tavolo "Brisa" si ispira alla forma di un fungo. Il suo profilo morbido e accogliente nasce dall'idea di stilizzare il cappello aperto della brisa in un paralume emisferico e il suo fusto carnoso in una base ampia e rotonda. Il risultato è una lampada sinuosa e resa elegante dalla soffiatura in vetro bianco.

The table lamp "Brisa" is designed over the shape of a mushroom. Its soft and cozy profile is born from the idea of abstracting the open hat of the "brisa" (a venetian mushroom) into a spheric lampshade and its sound body in a wide and rounded base. The result is a sinuous lamp, made elegant by the white blown glass.



BRISA
Fam. 1024

Photo: Table Lamp
White Milk Glass / White Painted
with E14 socket bulbs
Ø 500 mm H 600 mm
Art. TF 1024 TL / 3 / WM / WHITE

BRISA - PARASOL - SFIORO

Lampada da Tavolo Table Lamp

Item: **TF 1024 TL / 1**
Light Source: **E14 socket bulbs**
Power: **3x MAX 60 W**
(HSG P45 46 W supplied)
Voltage: **220 / 240 V** (110V Vers. USA)
Product Weight: **≈ 6 Kg / 13 lbs**

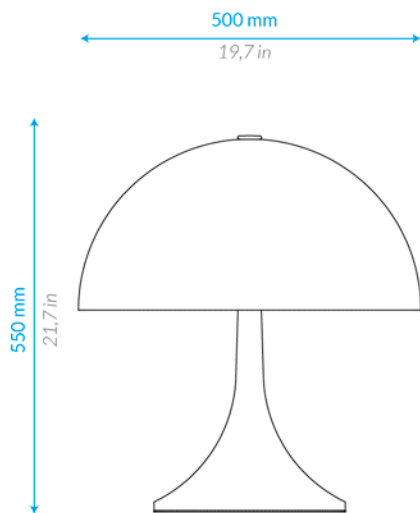

Lampada da Tavolo Table Lamp

Item: **TF 1024 TL / 2**
Light Source: **E14 socket bulbs**
Power: **3x MAX 60 W**
(HSG P45 46 W supplied dimmable)
Voltage: **220 / 240 V** (110V Vers. USA)
Product Weight: **≈ 6 Kg / 13 lbs**

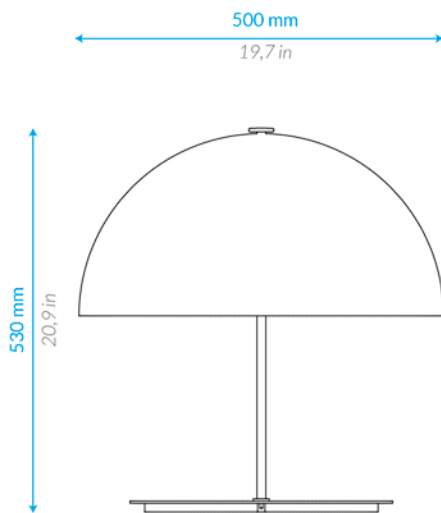

Lampada da Tavolo Table Lamp

Item: **TF 1024 TL / 3**
Light Source: **E14 socket bulbs**
Power: **3x MAX 40 W + 3 MAX 60 W**
(3 HSG P45 46 W + 3 HSG P45 46 W supplied dimmable)
Voltage: **220 / 240 V** (110V Vers. USA)
Product Weight: **≈ 8 Kg / 13 lbs**

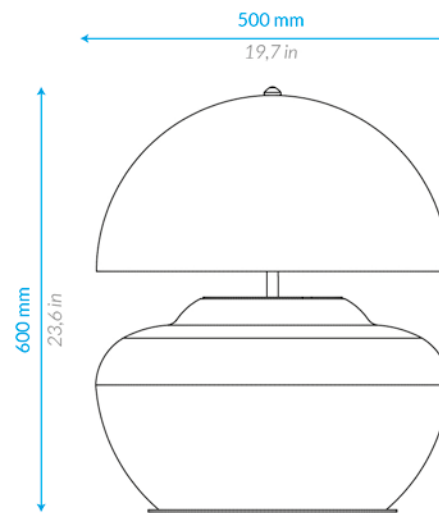

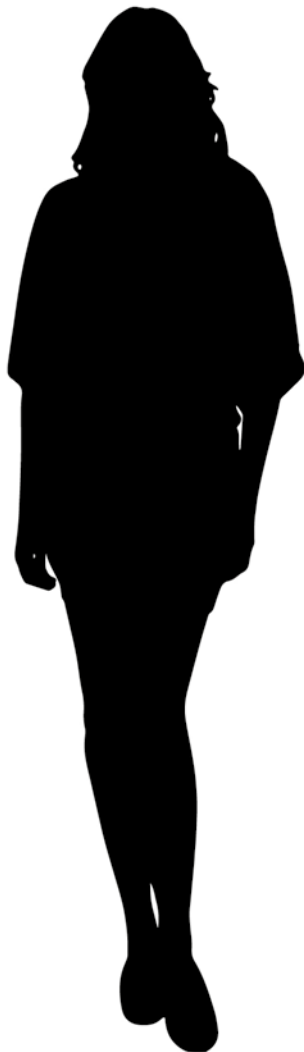

Disponibile in / Available in:

Colore Vetri / Glass Color

Trasparenti / Clear

CR	1	Cristallo Crystal	MA	7	Ametista Medio Medium Amethyst
MT	2	Topazio Medio Medium Topaz	DG	8	Grigio Grey
GG	3	Verde Erba Medio Medium Grass Green	CB	9	Blu Cobalto Cobalt Blue
MG	4	Verde Marino Chiaro Medium Marine Green	BL	10	Nero Black
DE	5	Verde Smeraldo Scuro Dark Emerald Green	MR	11	Rosso Medio Medium Red
DS	6	Acquamarina Scura Dark Sea Water			

Non Trasparenti / Solid

WM	12	Bianco White Milk	LG	18	Grigio Chiaro Light Grey
LG	13	Verde Pisello Light Green	IV	19	Avorio Ivory
NG	14	Verde Nilo Nile Green	PG	20	Grigio Perla Pearl Grey
BP	15	Pervinca Periwinkle	PP	21	Viola Purple
CS	16	Celeste Chiaro Clear Sky	PR	22	Rosso Porpora Chiaro Purple Red
DT	17	Turchese Scuro Dark Turquoise	DB	23	Marrone Scuro Dark Brown

Speciali / Special

LT GREY	29	Grigio Fumè Chiaro Smokey Light Grey	ST	35	Acciaio Trasp. Transp. Steel
DK GREY	30	Grigio Fumè Scuro Smokey Dark Grey	COR	36	Corniola Trasp. Transp. Carnelian
YEL	31	Giallo Limone Lemonish Yellow	AQUA	37	Acquamarina Trasp. Transp. Sea Water
VIOL	32	Violetto Violet	MC	38	Cristallo Specchiato Mirrored Crystal
GREY	33	Grigio Medio Medium Grey	GREEN	39	Verde Green
AM	34	Ametista Trasp. Transp. Amethyst			

Finiture / Finishing

A	Oro Lucido Glossy Gold Plated	G	Nero Opaco Matt Black RAL 9005
B	Cromo Lucido Glossy Chrome Plated	I	Bianco Opaco+Gomma Soft Matt White+Soft Rubber
C	Grigio Opaco Matt Grey RAL 7030	L	Ottone Brunito Burnished Brass
D	Beige Opaco Matt Beige RAL 1019	M	Acciaio Brunito Burnished Steel
E	Marrone Opaco Matt Brown RAL 8028	N	Bianco Verniciato White Painted
F	Bianco Opaco Matt White RAL 9003	O	Verniciatura Bronzo Bronze Painted

Lavorazioni / Techniques

PUL	PULEGOSO	RIG	RIGADIN
BAL	BALLOTON	SPIR	SPIRALE



INNER

Design Chiaramonte Marin





La sospensione "Inner" vuole rappresentare attraverso la semplicità di due sfere in vetro soffiato e posizionate l'una all'interno dell'altra, come la materia incandescente del vetro (sfera più piccola che contiene il corpo illuminante) si trasforma in qualcosa di leggero e trasparente (come la sfera più grande contenitore della piccola).

The suspension lamp "Inner" wants to represent, through the simplicity of two blown glass spheres put one inside the other, how glowing-hot glass material (the smaller sphere bearing the light source) turns into something transparent and lightweight (the bigger sphere which bears the smaller).



INNER
Fam. 1025

Photo: Lighting Suspension
Crystal Glass / Burnished Brass
with E27 socket bulb
Ø 500 mm
Art. TF 1025 SU1 / CR





Fam. 1025

INNER

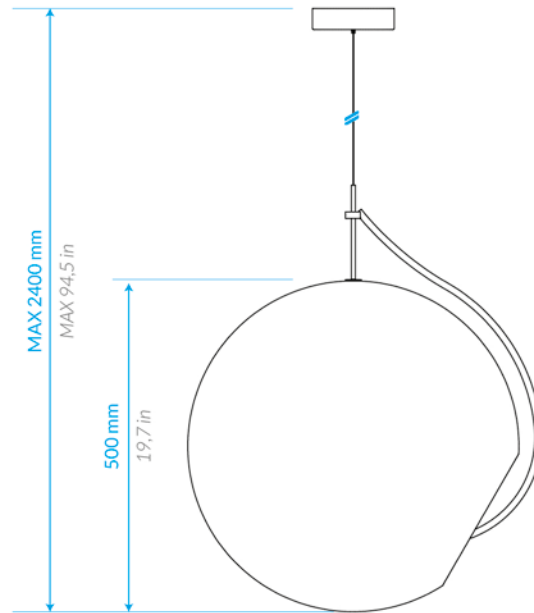

Sospensione Luminosa *Lighting Suspension*

Item: **TF 1025 SU / 1**

Light Source: **E27 socket bulb**

Power: **MAX 100 W** (HSG A55 77W supplied)

Voltage: **220 / 240 V** (110V Vers. USA)

Product Weight: **10 Kg / 22 lbs**

Disponibile in / Available in:

Colore Vetri / Glass Color

Trasparenti / Clear

CR	1	Cristallo Crystal	MA	7	Ametista Medio Medium Amethyst
MT	2	Topazio Medio Medium Topaz	DG	8	Grigio Grey
GG	3	Verde Erba Medio Medium Grass Green	CB	9	Blu Cobalto Cobalt Blue
MG	4	Verde Marino Chiaro Medium Marine Green	BL	10	Nero Black
DE	5	Verde Smeraldo Scuro Dark Emerald Green	MR	11	Rosso Medio Medium Red
DS	6	Acquamarina Scura Dark Sea Water			

Non Trasparenti / Solid

WM	12	Bianco White Milk	LG	18	Grigio Chiaro Light Grey
LG	13	Verde Pisello Light Green	IV	19	Avorio Ivory
NG	14	Verde Nilo Nile Green	PG	20	Grigio Perla Pearl Grey
BP	15	Pervinca Periwinkle	PP	21	Viola Purple
CS	16	Celeste Chiaro Clear Sky	PR	22	Rosso Porpora Chiaro Purple Red
DT	17	Turchese Scuro Dark Turquoise	DB	23	Marrone Scuro Dark Brown

Speciali / Special

LT GREY	29	Grigio Fumè Chiaro Smokey Light Grey	ST	35	Acciaio Trasp. Transp. Steel
DK GREY	30	Grigio Fumè Scuro Smokey Dark Grey	COR	36	Corniola Trasp. Transp. Carnelian
YEL	31	Giallo Limone Lemonish Yellow	AQUA	37	Acquamarina Trasp. Transp. Sea Water
VIOL	32	Violetto Violet	MC	38	Cristallo Specchiato Mirrored Crystal
GREY	33	Grigio Medio Medium Grey	GREEN	39	Verde Green
AM	34	Ametista Trasp. Transp. Amethyst			

Finiture / Finishing

A	Oro Lucido Glossy Gold Plated	G	Nero Opaco Matt Black RAL 9005
B	Cromo Lucido Glossy Chrome Plated	I	Bianco Opaco+Gomma Soft Matt White+Soft Rubber
C	Grigio Opaco Matt Grey RAL 7030	L	Ottone Brunito Burnished Brass
D	Beige Opaco Matt Beige RAL 1019	M	Acciaio Brunito Burnished Steel
E	Marrone Opaco Matt Brown RAL 8028	N	Bianco Verniciato White Painted
F	Bianco Opaco Matt White RAL 9003	O	Verniciatura Bronzo Bronze Painted

Lavorazioni / Techniques

PUL	PULEGOSO	RIG	RIGADIN
BAL	BALLOTON	SPIR	SPIRALE

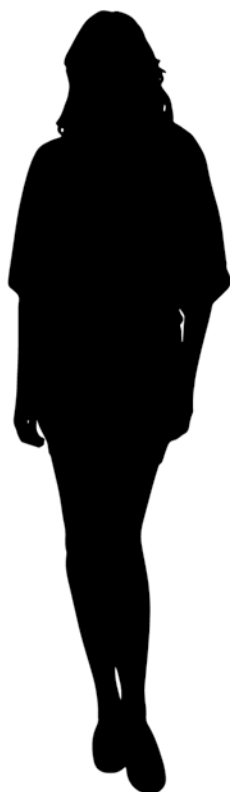

ERONE

Design Chiaramonte Marin





Le sospensioni "Erone" nascono dall'idea di creare delle lampade modulari dal forte impatto scenografico. Grandi sfere realizzate in vetro con tre diverse colorazioni possono essere utilizzate sia singolarmente che in sequenza come una sorta di grande collana. Le grandi "perle luminose" sono fissate ad un'unico cavo d'acciaio attraverso un singolare particolare in metallo tornito che armoniosamente collega i due elementi.

The suspension lamps "Erone" come from the idea of building modular lamps with a big aesthetic impact. Big spheres made of glass with three different colour tones can be used as a single lamp, as well as a sequence like a great necklace. The big "lighting pearls" are fixed by a single steel cable through a specific machined metal knot that armonically links the elements.



ERONE
Fam. 1026

Lighting Suspension
White Glass / White Painted Finished
with E27 Lights
Ø 300 mm

Composition:
1 x Art. TF 1026 SU1 / WHITE
2 x Art. TF 1026 SU2 / WHITE





ERONE

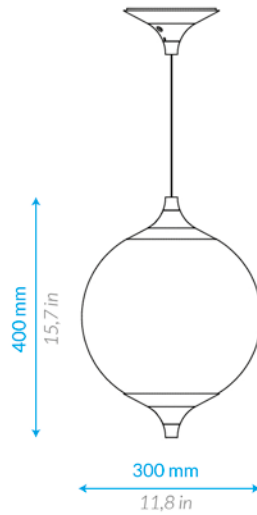

Sospensione Luminosa *Lighting Suspension*

Item: **TF 1026 SU / 1**
Light Source: **E27 socket bulb**
Power: **MAX 100 W**
(18 W LED bulb supplied)
Voltage: **220 / 240 V** (110V Vers. USA)
Product Weight: **≈ 5 Kg / 11 lbs**

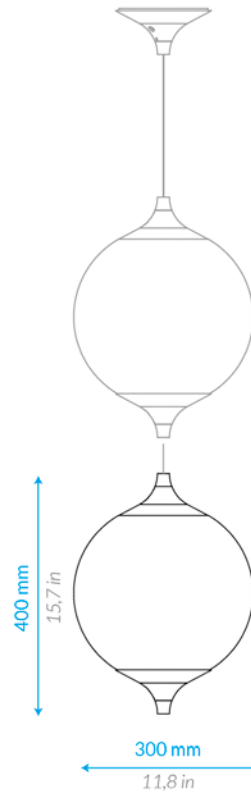

Vetro Luminoso Aggiuntivo *Additional Lighting Glass*

Item: **TF 1026 SU / 2**
Light Source: **E27 socket bulb**
Power: **MAX 100 W** (18W LED bulb supplied)
Voltage: **220 / 240 V** (110V Vers. USA)
Product Weight: **≈ 4 Kg / 8 lbs**

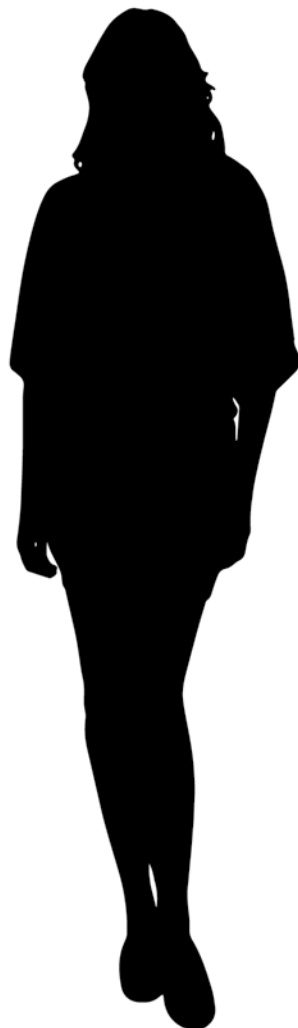

Disponibile in / Available in:

Colore Vetri / Glass Color

Trasparenti / Clear

CR	1	Cristallo Crystal	MA	7	Ametista Medio Medium Amethyst
MT	2	Topazio Medio Medium Topaz	DG	8	Grigio Grey
GG	3	Verde Erba Medio Medium Grass Green	CB	9	Blu Cobalto Cobalt Blue
MG	4	Verde Marino Chiaro Medium Marine Green	BL	10	Nero Black
DE	5	Verde Smeraldo Scuro Dark Emerald Green	MR	11	Rosso Medio Medium Red
DS	6	Acquamarina Scura Dark Sea Water			

Non Trasparenti / Solid

WM	12	Bianco White Milk	LG	18	Grigio Chiaro Light Grey
LG	13	Verde Pisello Light Green	IV	19	Avorio Ivory
NG	14	Verde Nilo Nile Green	PG	20	Grigio Perla Pearl Grey
BP	15	Pervinca Periwinkle	PP	21	Viola Purple
CS	16	Celeste Chiaro Clear Sky	PR	22	Rosso Porpora Chiaro Purple Red
DT	17	Turchese Scuro Dark Turquoise	DB	23	Marrone Scuro Dark Brown

Speciali / Special

LT GREY	29	Grigio Fumè Chiaro Smokey Light Grey	ST	35	Acciaio Trasp. Transp. Steel
DK GREY	30	Grigio Fumè Scuro Smokey Dark Grey	COR	36	Corniola Trasp. Transp. Carnelian
YEL	31	Giallo Limone Lemonish Yellow	AQUA	37	Acquamarina Trasp. Transp. Sea Water
VIOL	32	Violetto Violet	MC	38	Cristallo Specchiato Mirrored Crystal
GREY	33	Grigio Medio Medium Grey	GREEN	39	Verde Green
AM	34	Ametista Trasp. Transp. Amethyst			

Finiture / Finishing

A	Oro Lucido Glossy Gold Plated	G	Nero Opaco Matt Black RAL 9005
B	Cromo Lucido Glossy Chrome Plated	I	Bianco Opaco+Gomma Soft Matt White+Soft Rubber
C	Grigio Opaco Matt Grey RAL 7030	L	Ottone Brunito Burnished Brass
D	Beige Opaco Matt Beige RAL 1019	M	Acciaio Brunito Burnished Steel
E	Marrone Opaco Matt Brown RAL 8028	N	Bianco Verniciato White Painted
F	Bianco Opaco Matt White RAL 9003	O	Verniciatura Bronzo Bronze Painted

Lavorazioni / Techniques

PUL	PULEGOSO	RIG	RIGADIN
BAL	BALLOTON	SPIR	SPIRALE



JIMMY

Design Chiaramonte Marin



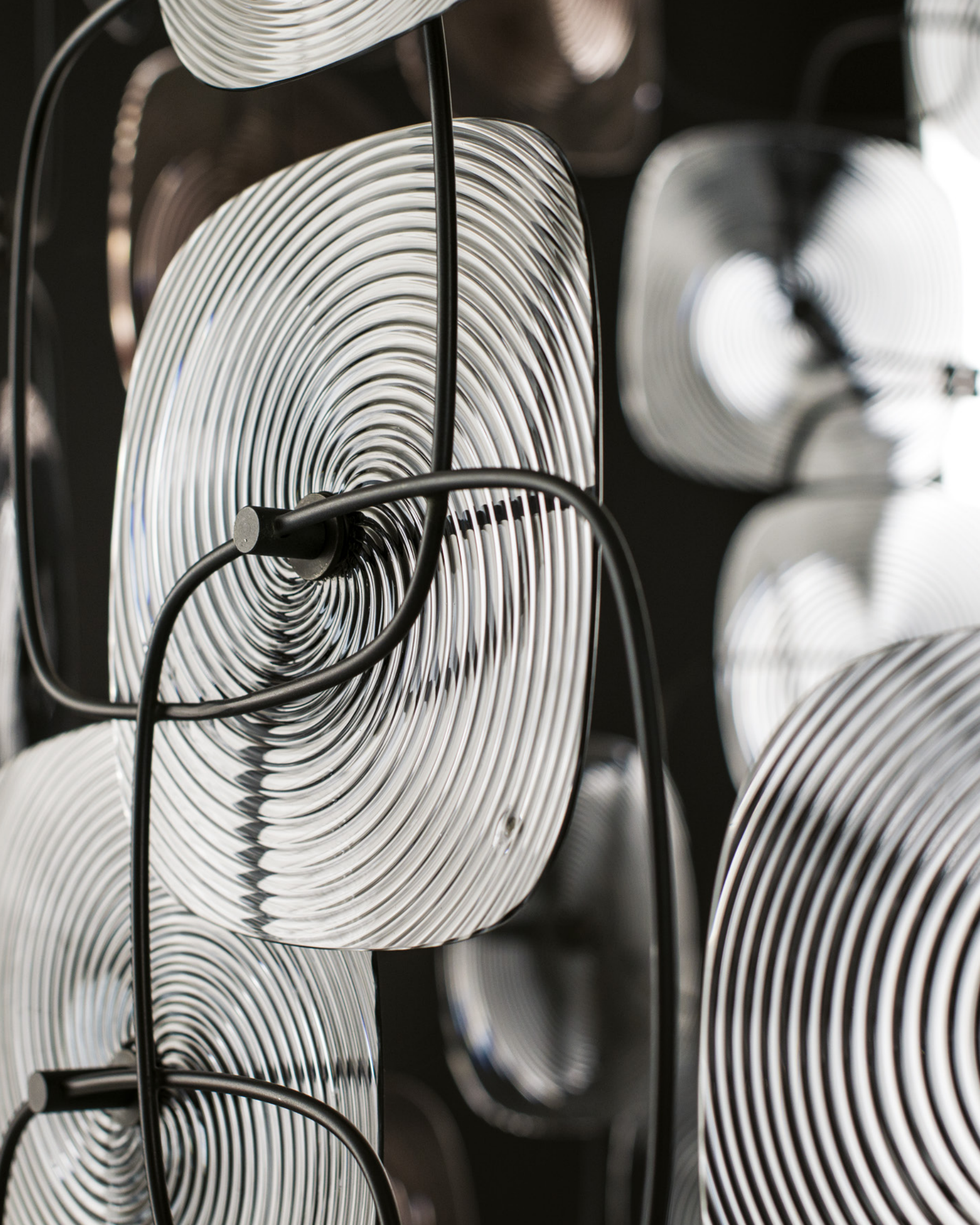

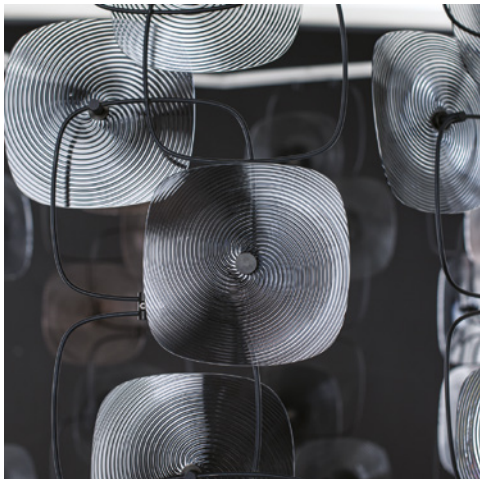

Jimmy non è solo una lampada a sospensione ma, grazie al design modulare con cui è concepito, è un oggetto che può facilmente trasformarsi in una scultura, anch'essa componibile, che rimanda alla mente le sperimentazioni ottico cinetiche dell'arte e del design anni '70.

Jimmy is not only a suspension lamp but, thanks to the modular design in which it is conceived, is an object that can easily turn into a modular sculpture, which reminds you of the 70s optical experiments with kinetic art and designs.

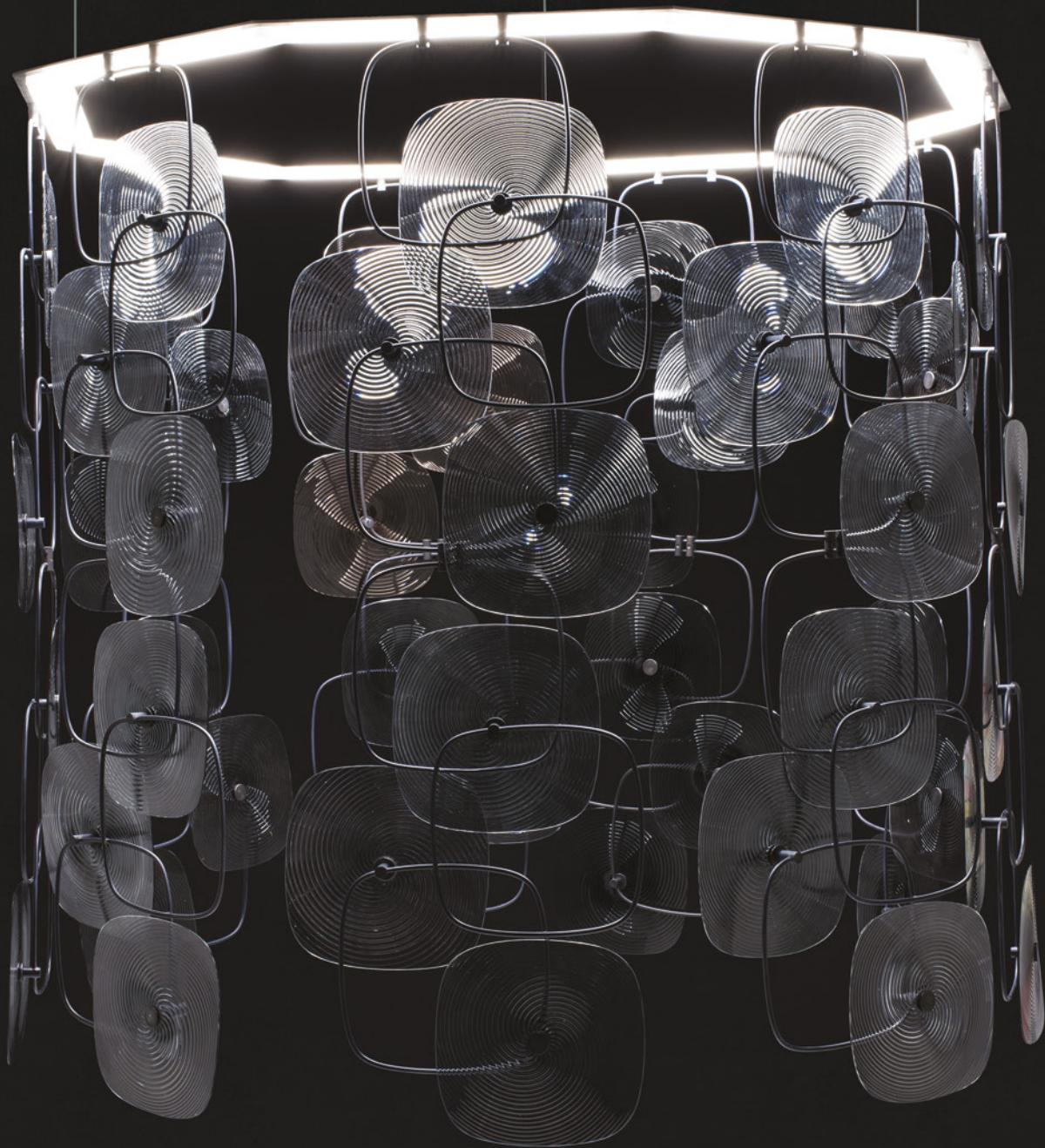

JIMMY
Fam. 1027

Photo: Lighting Suspension
Crystal, Transparent Steel
Transparent Corniola / Burnished Steel
with Led modules
Ø 1200 mm H 120 mm
Art. TF 1027 SU / 54

JIMMY

COMPOSIZIONE A PARETE

Una parte importante della progettazione di Jimmy consiste nella volontà di dare all'utente la possibilità di interagire con l'oggetto, in base al gusto e alle necessità personali. Combinando i moduli alle appliques luminose, Jimmy diventa una lampada da parete, funzionale e dal forte impatto visivo, potenzialmente estensibile all'infinito.

WALL COMPOSITION

An important part of the planning of Jimmy is the desire to give the user the ability to interact with the object, according to personal taste and needs. By combining the modules to light appliques, Jimmy becomes a wall lamp, with a functional and strong visual impact, potentially expandable endlessly.

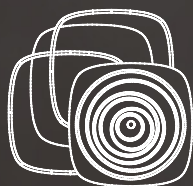

1 Light Wall Lamp
TF 1027 WS / 1

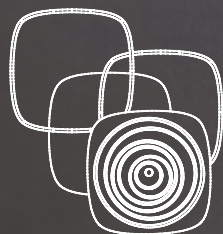

1 Light Wall Lamp
TF 1027 WS / 2

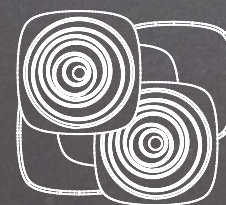

1 Light Wall Lamp
TF 1027 WS / 3

No Lighting Form
6 glasses
Art. TF 1027 WS / 5

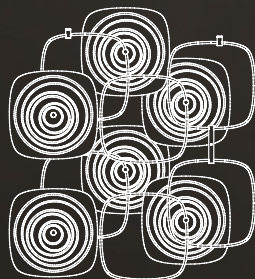

No Lighting Form
12 glasses
Art. TF 1027 WS / 6

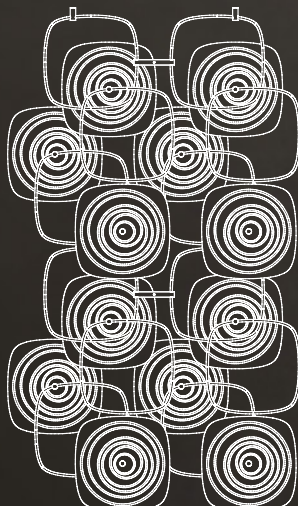

No Lighting Form
6 glasses
Art. TF 1027 WS / 4

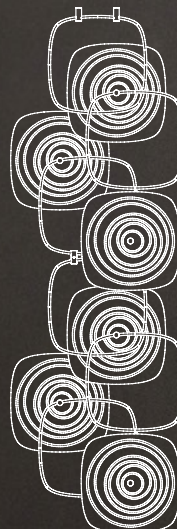

No Lighting Form
12 glasses
Art. TF 1027 WS / 7

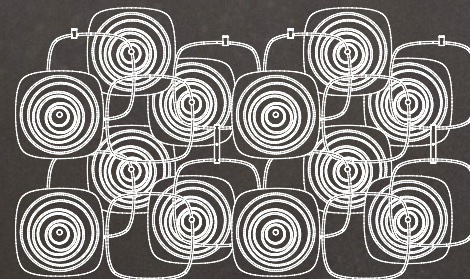



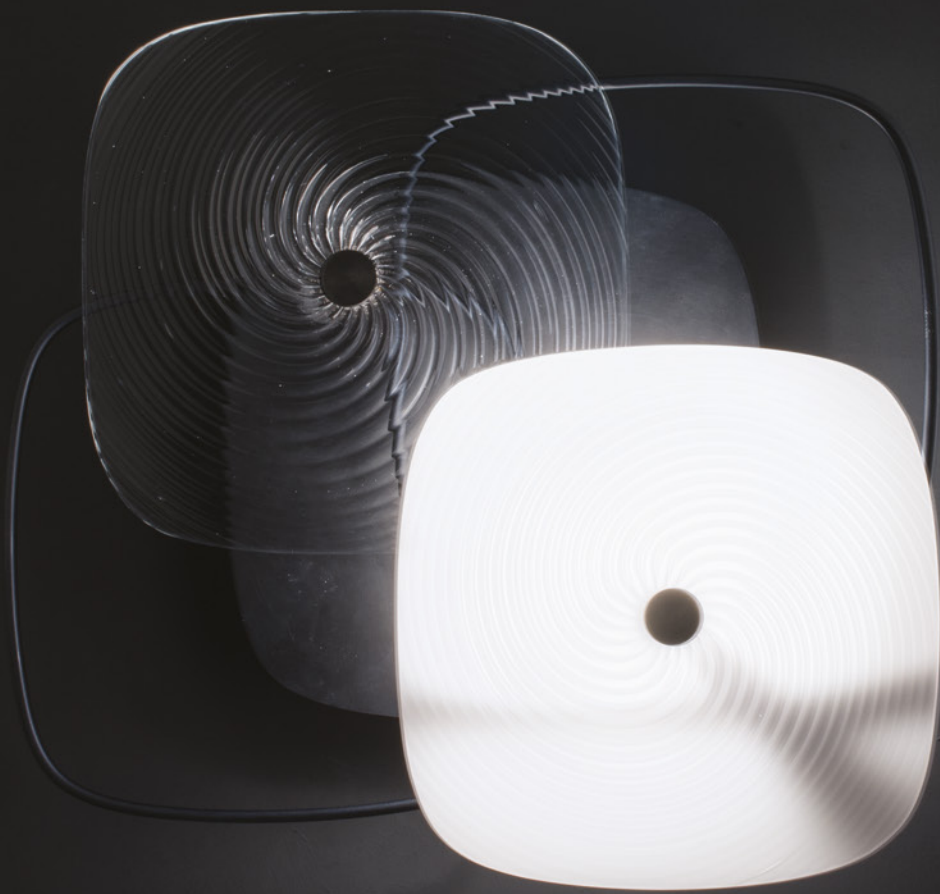

JIMMY
Fam. 1027

Photo: 1 Light Wall Lamp
Crystal, Transparent Steel / Burnished Steel
with Led module
L 370 mm H 330 mm
Art. TF 1027 WS / 3 / ST



No Lighting Form
6 glasses
Art. TF 1027 WS / 5

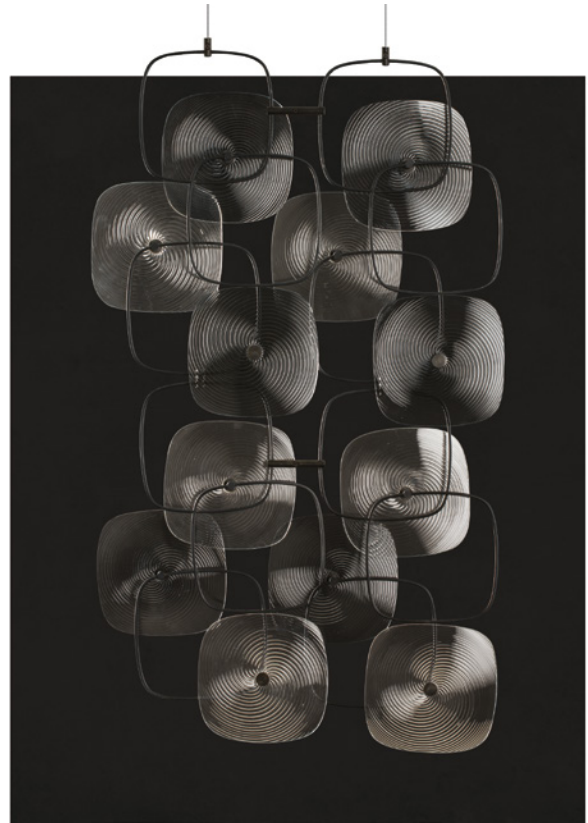

No Lighting Form
12 glasses
Art. TF 1027 WS / 6



No Lighting Form
6 glasses
Art. TF 1027 WS / 4



No Lighting Form
12 glasses
Art. TF 1027 WS / 7

JIMMY

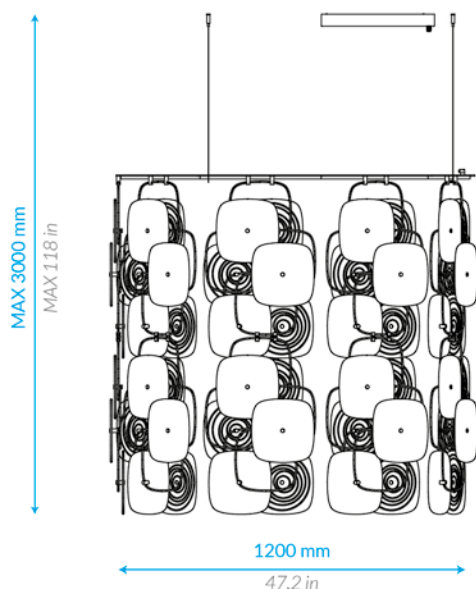

Sospensione Luminosa
Lighting Suspension

Item: **TF 1027 SU / 54**
 Light Source: **LED modules**
 Power: **62,1 W**
 Voltage: **220 / 240 V** (110V Vers. USA)
 Product Weight: **16 Kg / 32 lbs**



Modulo 6 vetri
No Lighting Form - 6 glasses

Item: **TF 1027 WS / 4**
 Product Weight: **2,5 Kg / 5 lbs**

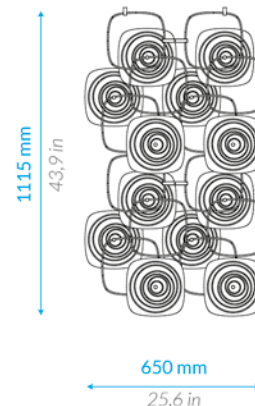

Modulo 12 vetri
No Lighting Form - 12 glasses

Item: **TF 1027 WS / 6**
 Product Weight: **2,5 Kg / 5 lbs**

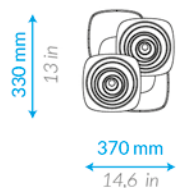

Applique 1 Luce
1 Light Wall Lamp

Item: **TF 1027 WS / 3**
 Light Source: **LED modules**
 Power: **8,9 W**
 Voltage: **220 / 240 V** (110V Vers. USA)
 Product Weight: **3,5 Kg / 7 lbs**

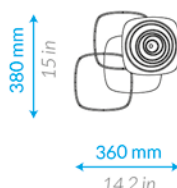

Applique 1 Luce
1 Light Wall Lamp

Item: **TF 1027 WS / 2**
 Light Source: **LED modules**
 Power: **8,9 W**
 Voltage: **220 / 240 V** (110V Vers. USA)
 Product Weight: **3 Kg / 6 lbs**

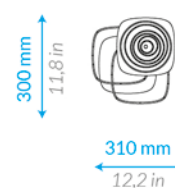

Applique 1 Luce
1 Light Wall Lamp

Item: **TF 1027 WS / 1**
 Light Source: **LED modules**
 Power: **8,9 W**
 Voltage: **220 / 240 V** (110V Vers. USA)
 Product Weight: **3 Kg / 6 lbs**

Disponibile in / Available in:

Colore Vetri / Glass Color

Trasparenti / Clear

CR	1	Cristallo Crystal	MA	7	Ametista Medio Medium Amethyst
MT	2	Topazio Medio Medium Topaz	DG	8	Grigio Grey
GG	3	Verde Erba Medio Medium Grass Green	CB	9	Blu Cobalto Cobalt Blue
MG	4	Verde Marino Chiaro Medium Marine Green	BL	10	Nero Black
DE	5	Verde Smeraldo Scuro Dark Emerald Green	MR	11	Rosso Medio Medium Red
DS	6	Acquamarina Scura Dark Sea Water			

Non Trasparenti / Solid

WM	12	Bianco White Milk	LG	18	Grigio Chiaro Light Grey
LG	13	Verde Pisello Light Green	IV	19	Avorio Ivory
NG	14	Verde Nilo Nile Green	PG	20	Grigio Perla Pearl Grey
BP	15	Pervinca Periwinkle	PP	21	Viola Purple
CS	16	Celeste Chiaro Clear Sky	PR	22	Rosso Porpora Chiaro Purple Red
DT	17	Turchese Scuro Dark Turquoise	DB	23	Marrone Scuro Dark Brown

Speciali / Special

LT GREY	29	Grigio Fumè Chiaro Smokey Light Grey	ST	35	Acciaio Trasp. Transp. Steel
DK GREY	30	Grigio Fumè Scuro Smokey Dark Grey	COR	36	Corniola Trasp. Transp. Carnelian
YEL	31	Giallo Limone Lemonish Yellow	AQUA	37	Acquamarina Trasp. Transp. Sea Water
VIOL	32	Violetto Violet	MC	38	Cristallo Specchiato Mirrored Crystal
GREY	33	Grigio Medio Medium Grey	GREEN	39	Verde Green
AM	34	Ametista Trasp. Transp. Amethyst			

Finiture / Finishing

A	Oro Lucido Glossy Gold Plated	G	Nero Opaco Matt Black RAL 9005
B	Cromo Lucido Glossy Chrome Plated	I	Bianco Opaco+Gomma Soft Matt White+Soft Rubber
C	Grigio Opaco Matt Grey RAL 7030	L	Ottone Brunito Burnished Brass
D	Beige Opaco Matt Beige RAL 1019	M	Acciaio Brunito Burnished Steel
E	Marrone Opaco Matt Brown RAL 8028	N	Bianco Verniciato White Painted
F	Bianco Opaco Matt White RAL 9003	O	Verniciatura Bronzo Bronze Painted

Lavorazioni / Techniques

PUL	PULEGOSO	RIG	RIGADIN
BAL	BALLOTON	SPIR	SPIRALE

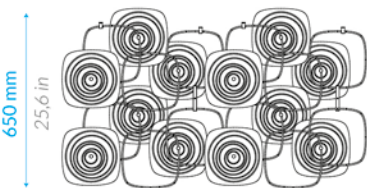

1100 mm

43,3 in

Modulo 12 vetri

No Lighting Form - 12 glasses

Item: **TF 1027 WS / 7**

Product Weight: **5 Kg / 10 lbs**

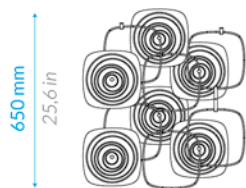

580 mm

22,8 in

Modulo 6 vetri

No Lighting Form - 12 glasses

Item: **TF 1027 WS / 5**

Product Weight: **2,5 Kg / 5 lbs**

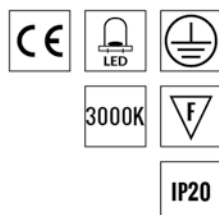

FORMOSA







Formosa si ispira alla grande tradizione veneziana, ed in particolare alla tipologia definita Ca' Rezzonico. Formosa si costituisce di una serie di elementi minuti e raffinati, pendenti, riccioli e volute, con inserti in foglia d'oro, che vanno a formare un insieme florido e rigoglioso, e scendono a cascata fino ai bracci a bossette ampi e accoglienti. Scegliere Formosa, significa rivivere un pezzo di storia di una delle più affascinanti città del mondo e illuminare la tua casa con la magia e il lusso dei saloni da ballo.

Formosa is inspired by the great Venetian tradition, particularly the type defined as Ca 'Rezzonico. Formosa is constituted of a number of minute and refined elements, pendants, curls and spirals, with inserts of a golden leaf, which form a prosperous and flourishing cascade down to the arms spaciously and comfortably. Choosing Formosa, does not only mean choosing a piece of furniture but reliving a piece of history of one of the most fascinating cities in the world and brighten your home with the magic and luxury of ballrooms.

FORMOSA
Fam. 1005

Photo: 12 Arms Chandelier
Ivory Glass / Glossy Gold Plated
with Led lights
Ø 1750 mm H 2200 mm
Art. TF 1005 CH / 12 IV / GOLD







FORMOSA

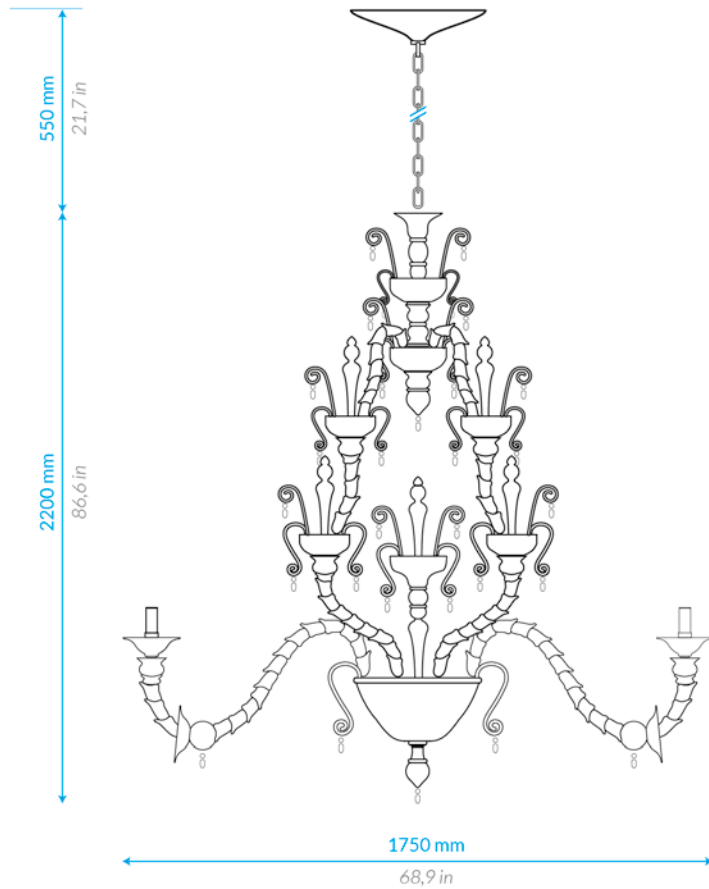

Lampadario 12 Bracci
12 Arms Chandelier

Item: **TF 1005 CH / 12**
Light Source: **LED 12 x 7,4 W + 24 x 1,4 W**
Power: **122,4 W**
Voltage: **220 / 240 V** (110V Vers. USA)
Product Weight: **80 Kg / lbs 160**

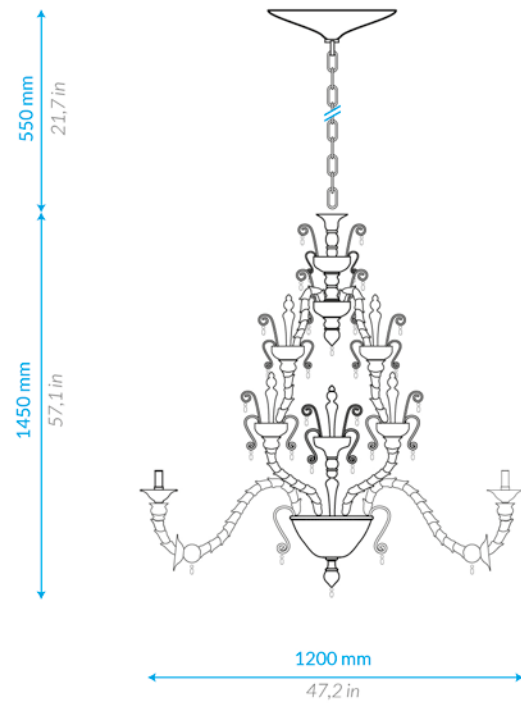

Lampadario 9 Bracci
9 Arms Chandelier

Item: **TF 1005 CH / 9**
Light Source: **LED 9 x 7,4 W + 24 x 1,4 W**
Power: **100,2 W**
Voltage: **220 / 240 V** (110V Vers. USA)
Product Weight: **70 Kg / lbs 150**

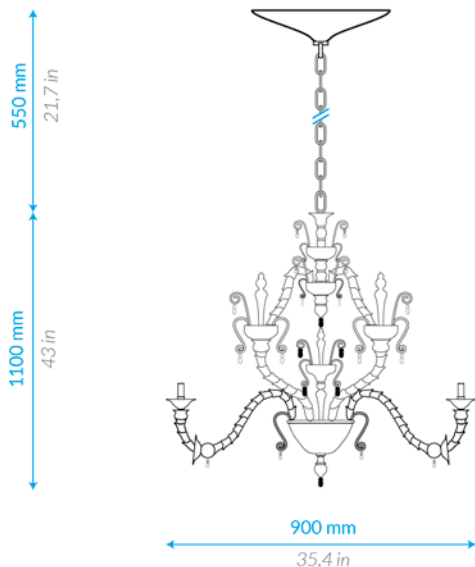

Lampadario 6 Bracci 6 Arms Chandelier

Item: **TF 1005 CH / 6**
 Light Source: **LED 6 x 7,4 W + 15 x 1,4 W**
 Power: **65,40 W**
 Voltage: **220 / 240 V** (110V Vers. USA)
 Product Weight: **40 Kg / lbs 80**

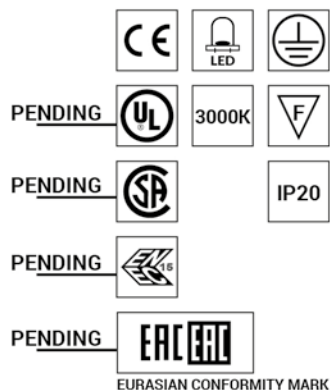

Disponibile in / Available in:

Colore Vetri / Glass Color

Trasparenti / Clear

CR	1	Cristallo Crystal	MA	7	Ametista Medio Medium Amethyst
MT	2	Topazio Medio Medium Topaz	DG	8	Grigio Grey
GG	3	Verde Erba Medio Medium Grass Green	CB	9	Blu Cobalto Cobalt Blue
MG	4	Verde Marino Chiaro Medium Marine Green	BL	10	Nero Black
DE	5	Verde Smeraldo Scuro Dark Emerald Green	MR	11	Rosso Medio Medium Red
DS	6	Acquamarina Scura Dark Sea Water			

Non Trasparenti / Solid

WM	12	Bianco White Milk	LG	18	Grigio Chiaro Light Grey
LG	13	Verde Pisello Light Green	IV	19	Avorio Ivory
NG	14	Verde Nilo Nile Green	PG	20	Grigio Perla Pearl Grey
BP	15	Pervinca Periwinkle	PP	21	Viola Purple
CS	16	Celeste Chiaro Clear Sky	PR	22	Rosso Porpora Chiaro Purple Red
DT	17	Turchese Scuro Dark Turquoise	DB	23	Marrone Scuro Dark Brown

Speciali / Special

LT GREY	29	Grigio Fumè Chiaro Smokey Light Grey	ST	35	Acciaio Trasp. Transp. Steel
DK GREY	30	Grigio Fumè Scuro Smokey Dark Grey	COR	36	Corniola Trasp. Transp. Carnelian
YEL	31	Giallo Limone Lemonish Yellow	AQUA	37	Acquamarina Trasp. Transp. Sea Water
VIOL	32	Violetto Violet	MC	38	Cristallo Specchiato Mirrored Crystal
GREY	33	Grigio Medio Medium Grey	GREEN	39	Verde Green
AM	34	Ametista Trasp. Transp. Amethyst			

Finiture / Finishing

A	Oro Lucido Glossy Gold Plated	G	Nero Opaco Matt Black RAL 9005
B	Cromo Lucido Glossy Chrome Plated	I	Bianco Opaco+Gomma Soft Matt White+Soft Rubber
C	Grigio Opaco Matt Grey RAL 7030	L	Ottone Brunito Burnished Brass
D	Beige Opaco Matt Beige RAL 1019	M	Acciaio Brunito Burnished Steel
E	Marrone Opaco Matt Brown RAL 8028	N	Bianco Verniciato White Painted
F	Bianco Opaco Matt White RAL 9003	O	Verniciatura Bronzo Bronze Painted

Lavorazioni / Techniques

PUL	PULEGOSO	RIG	RIGADIN
BAL	BALLOTON	SPIR	SPIRALE

CAENA





Caena non è solo un sistema di illuminazione, è molto di più: è la tradizione del vetro di Murano sposata alla ricerca nel campo dell'ingegneria luminosa. Il suo nome deriva dal veneziano e significa catena; proprio come una catena, questo oggetto di design si compone di anelli, ognuno dei quali è dotato di un circuito luminoso interno. Questa caratteristica consente di rendere la maglia estensibile e totalmente personalizzabile.

Caena is not just a lighting system, it is much more: it is the tradition of Murano glass married to research in the field of light. Its name comes from the Venetian language and means chain; just like a chain, this design object is composed of rings, each of which is equipped with a bright circuit interior. This feature allows you to make the shirt extensible and fully customizable.



CAENA
Fam. 2002

Photo: Lighting Hook 2 Connection
Crystal Ivory Glass
with Led lights
L 130 mm H 210 mm
Art. TF 2001 / HW / GL / CR IV





1



2



3



Caena nasce da un oggetto, un lighting hook, di un design puro ed essenziale, che può essere "appeso" ad un attacco da soffitto, singolo o multiplo, in una serie di combinazioni che vanno da un minimo di uno ad un massimo di 20 ganci per ciascun attacco.

Caena originates from an object, a lighting hook, of a pure and essential design, which can be "hung" to an attack from the ceiling, single or multiple, in a series of combinations ranging from a minimum of one to a maximum of 20 hooks for each attack.

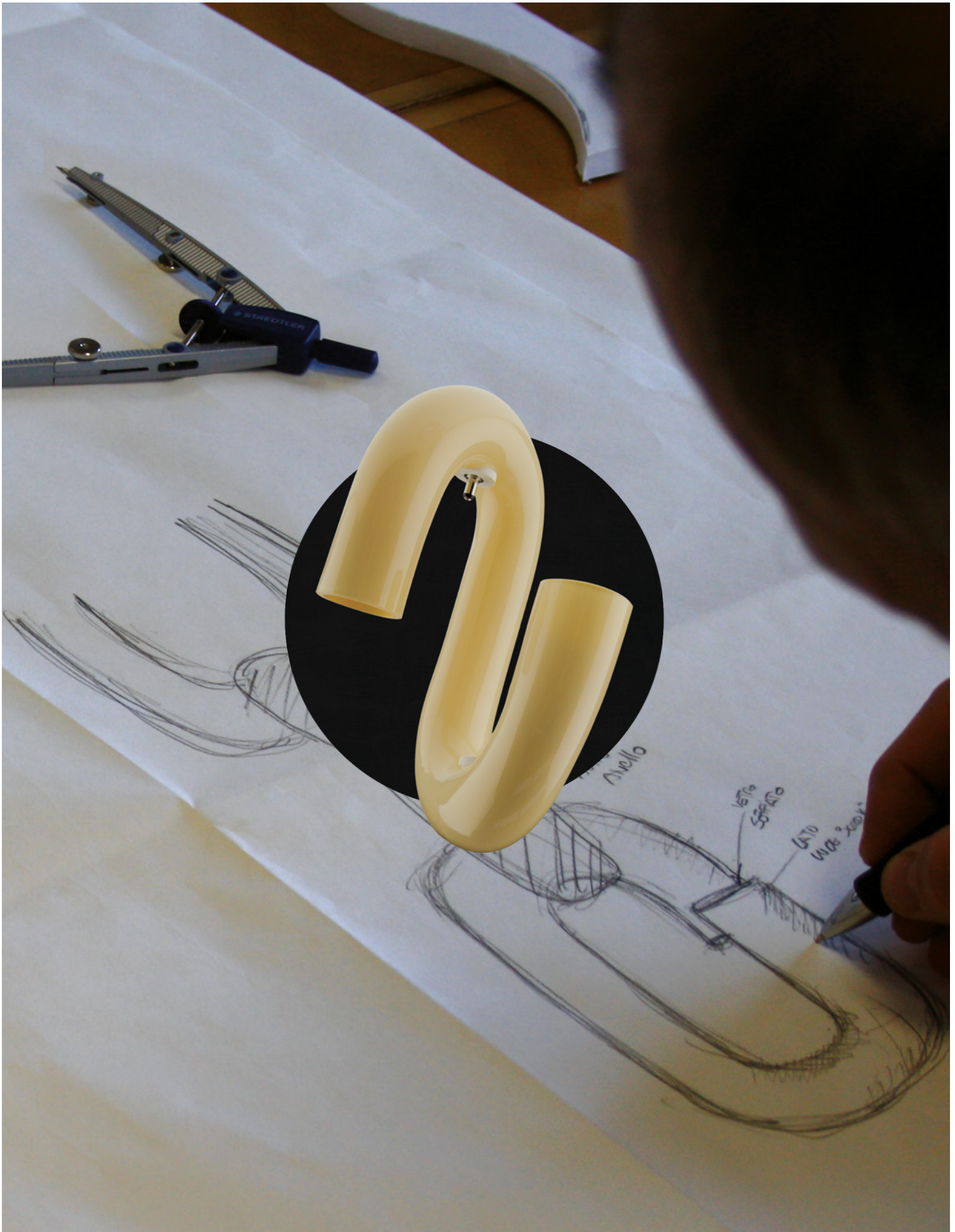



**Bevilacqua
Grottesche**

100% seta
H 68 cm
Rapporto 140 cm

100% seta
H 68 cm
Rapporto 140 cm

Velluto appropazito in seta
realizzato a mano su telaio
jacquard originale del XVIII-XIX
secolo.

La decorazione ripropone
lo stile eclettico tipico di tarda
Ottocento riproducendo
fedelmente per tecnica
e disegno un campione storico
del XIX secolo custodito presso
la Tessitura dell'Archivio Luigi
Bevilacqua ed esposto
in importanti mostre storiche.

Decorazione silk velvet,
hand woven on an original
XVIII-XIX century Jacquard
loom.

The decoration revisits
the typical versatile style
of the late 1800s, faithfully
reproducing the technique
and design of a sample from
the XIX century kept at the
Luigi Bevilacqua's Archive and
shown at important historical
exhibitions.



Luigi Bevilacqua

PLEASE
DON'T TOUCH
NON TOCCARE



Abate Zanetti for
La Biennale di Venezia
55th International Art Exhibition



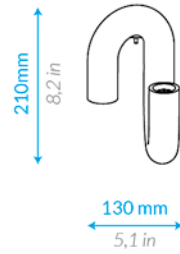

Gancio Luminoso, 1 Connessione
Lighting Hook, 1 Connection

Item: **TF 2001 HW**
Light Source: **LED POINT 2 x 0,5 W**
Power: **1 W**
Voltage: **12 V DC**
Product Weight: **0,5 Kg / lbs 1,1**

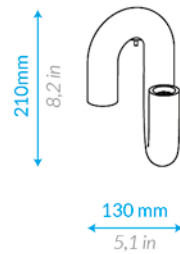

Gancio Luminoso, 2 Connessioni
Lighting Hook, 2 Connections

Item: **TF 2002 HW**
Light Source: **LED POINT 2 x 0,5 W**
Power: **1 W**
Voltage: **12 V DC**
Product Weight: **0,5 Kg / lbs 1,1**



Disponibile in / Available in:

Colore Vetri / Glass Color

Trasparenti / Clear

CR	1	Cristallo Crystal	MA	7	Ametista Medio Medium Amethyst
MT	2	Topazio Medio Medium Topaz	DG	8	Grigio Grey
GG	3	Verde Erba Medio Medium Grass Green	CB	9	Blu Cobalto Cobalt Blue
MG	4	Verde Marino Chiaro Medium Marine Green	BL	10	Nero Black
DE	5	Verde Smeraldo Scuro Dark Emerald Green	MR	11	Rosso Medio Medium Red
DS	6	Acquamarina Scura Dark Sea Water			

Non Trasparenti / Solid

WM	12	Bianco White Milk	LG	18	Grigio Chiaro Light Grey
LG	13	Verde Pisello Light Green	IV	19	Avorio Ivory
NG	14	Verde Nilo Nile Green	PG	20	Grigio Perla Pearl Grey
BP	15	Pervinca Periwinkle	PP	21	Viola Purple
CS	16	Celeste Chiaro Clear Sky	PR	22	Rosso Porpora Chiaro Purple Red
DT	17	Turchese Scuro Dark Turquoise	DB	23	Marrone Scuro Dark Brown

Speciali / Special

LT GREY	29	Grigio Fumè Chiaro Smokey Light Grey	ST	35	Acciaio Trasp. Transp. Steel
DK GREY	30	Grigio Fumè Scuro Smokey Dark Grey	COR	36	Corniola Trasp. Transp. Carnelian
YEL	31	Giallo Limone Lemonish Yellow	AQUA	37	Acquamarina Trasp. Transp. Sea Water
VIOL	32	Violetto Violet	MC	38	Cristallo Specchiato Mirrored Crystal
GREY	33	Grigio Medio Medium Grey	GREEN	39	Verde Green
AM	34	Ametista Trasp. Transp. Amethyst			

Finiture / Finishing

A	Oro Lucido Glossy Gold Plated	G	Nero Opaco Matt Black RAL 9005
B	Cromo Lucido Glossy Chrome Plated	I	Bianco Opaco+Gomma Soft Matt White+Soft Rubber
C	Grigio Opaco Matt Grey RAL 7030	L	Ottone Brunito Burnished Brass
D	Beige Opaco Matt Beige RAL 1019	M	Acciaio Brunito Burnished Steel
E	Marrone Opaco Matt Brown RAL 8028	N	Bianco Verniciato White Painted
F	Bianco Opaco Matt White RAL 9003	O	Verniciatura Bronzo Bronze Painted

Lavorazioni / Techniques

PUL	PULEGOSO	RIG	RIGADIN
BAL	BALLOTON	SPIR	SPIRALE

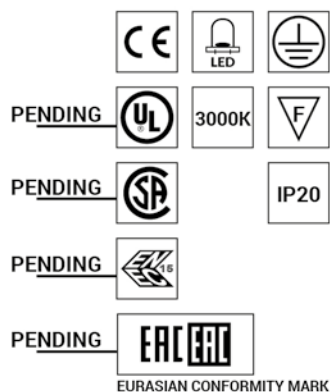
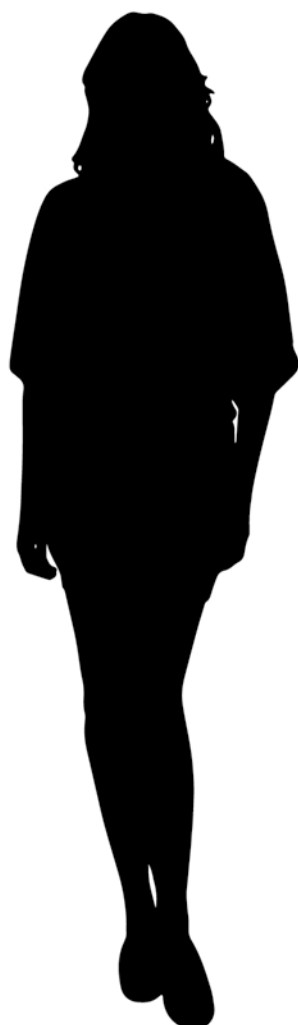

SUPERRCAENA







SUPERCAENA
Fam. 3005

Photo: 3 Lighting Hooks Supercaena
white glass
with 6 Led modules
H 460mm
2002SU1/WHITE



SUPERCAENA
Fam. 3005

Photo: 3 Lighting Hooks Supercaena
Crystal Ivory Glass
with 6 Led modules
H 460mm
TF 3005 HW / GL / CR IV



SUPERCAENA
Fam. 3005

Photo: 3 Lighting Hooks Supercaena
Crystal Dark Grey Glass
with 6 Led modules
H 460mm
TF 3005 HW / GL / CR DKGREY

SUPERCAENA
Fam. 3005

Photo: 3 Lighting Hooks Supercaena
Crystal White Milk Glass
with 6 Led modules
H 460mm
TF 3005 HW / GL / CR WM

Fam. 3005

SUPERCAENA

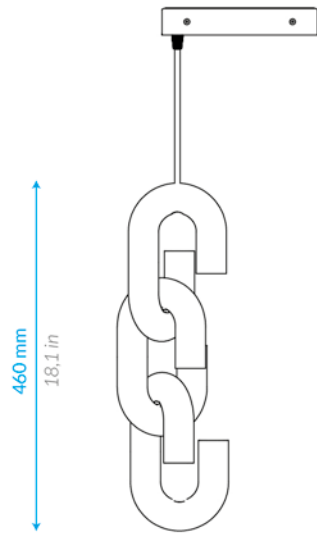

3 Ganci Luminosi Supercaena *3 Lighting Hooks Supercaena*

Item: **TF 3005 HW**
Light Source: **6 LED modules**
Power: **18 W**
Voltage: **110 / 240 V**
Product Weight: **3,5 Kg / lbs 7**

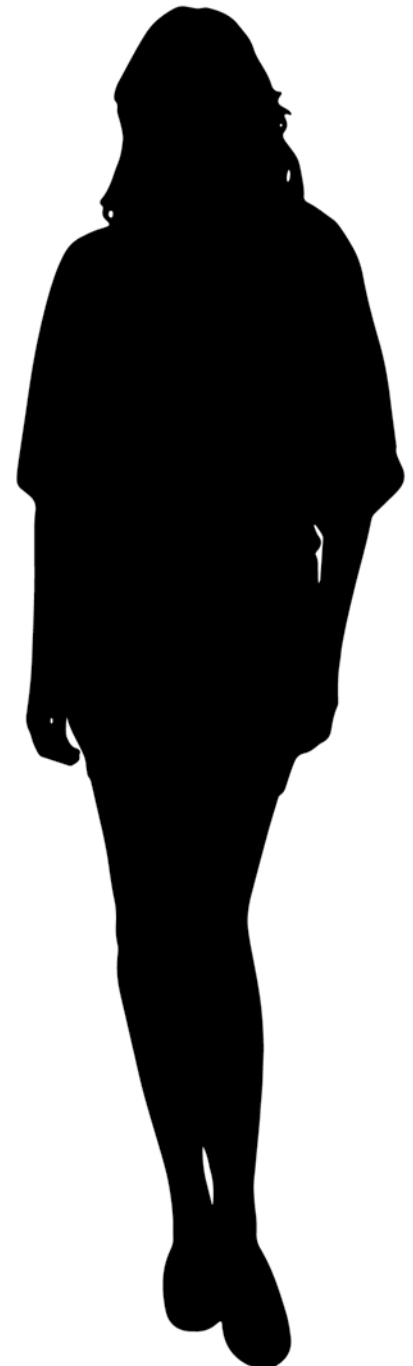

Disponibile in / Available in:

Colore Vetri / Glass Color

Trasparenti / Clear

CR	1	Cristallo Crystal	MA	7	Ametista Medio Medium Amethyst
MT	2	Topazio Medio Medium Topaz	DG	8	Grigio Grey
GG	3	Verde Erba Medio Medium Grass Green	CB	9	Blu Cobalto Cobalt Blue
MG	4	Verde Marino Chiaro Medium Marine Green	BL	10	Nero Black
DE	5	Verde Smeraldo Scuro Dark Emerald Green	MR	11	Rosso Medio Medium Red
DS	6	Acquamarina Scura Dark Sea Water			

Non Trasparenti / Solid

WM	12	Bianco White Milk	LG	18	Grigio Chiaro Light Grey
LG	13	Verde Pisello Light Green	IV	19	Avorio Ivory
NG	14	Verde Nilo Nile Green	PG	20	Grigio Perla Pearl Grey
BP	15	Pervinca Periwinkle	PP	21	Viola Purple
CS	16	Celeste Chiaro Clear Sky	PR	22	Rosso Porpora Chiaro Purple Red
DT	17	Turchese Scuro Dark Turquoise	DB	23	Marrone Scuro Dark Brown

Speciali / Special

LT GREY	29	Grigio Fumè Chiaro Smoky Light Grey	ST	35	Acciaio Trasp. Transp. Steel
DK GREY	30	Grigio Fumè Scuro Smoky Dark Grey	COR	36	Corniola Trasp. Transp. Carnelian
YEL	31	Giallo Limone Lemonish Yellow	AQUA	37	Acquamarina Trasp. Transp. Sea Water
VIOL	32	Violetto Violet	MC	38	Cristallo Specchiato Mirrored Crystal
GREY	33	Grigio Medio Medium Grey	GREEN	39	Verde Green
AM	34	Ametista Trasp. Transp. Amethyst			

Finiture / Finishing

A	Oro Lucido Glossy Gold Plated	G	Nero Opaco Matt Black RAL 9005
B	Cromo Lucido Glossy Chrome Plated	I	Bianco Opaco+Gomma Soft Matt White+Soft Rubber
C	Grigio Opaco Matt Grey RAL 7030	L	Ottone Brunito Burnished Brass
D	Beige Opaco Matt Beige RAL 1019	M	Acciaio Brunito Burnished Steel
E	Marrone Opaco Matt Brown RAL 8028	N	Bianco Verniciato White Painted
F	Bianco Opaco Matt White RAL 9003	O	Verniciatura Bronzo Bronze Painted

Lavorazioni / Techniques

PUL	PULEGOSO	RIG	RIGADIN
BAL	BALLOTON	SPIR	SPIRALE

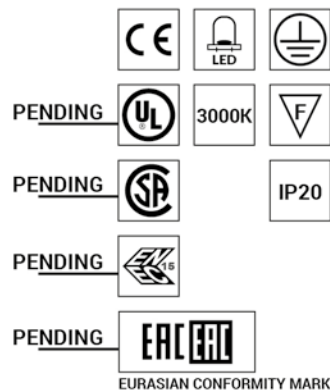

SAMÌS







Samis è uno sfarzoso lampadario in vetro di Murano, le cui forme e materiali riprendono l'opulenza del passato. Samis rielabora la tipologia del lampadario detto a ciocca, inventato a Murano nel XVIII secolo. Il suo insieme nonostante sia classico, è vivace e movimentato: i bracci assieme ai piccoli elementi che lo compongono, foglie e peroli (pendenti a forma di pera), impreziositi in foglia d'oro, intessono tra loro un dialogo e quasi sembrano danzare dinnanzi gli occhi di lo guarda.

Samis is a gorgeous chandelier in Murano glass, whose forms and materials take up the opulence of the past. Samis revises the type of chandelier told strand, invented at Murano in the eighteenth century. It's its entirety despite classic, is lively and bustling: the arms along with the small elements that compose it, and Peroli leaves (pear-shaped pendants), embellished in gold foil, weave a dialogue between them and almost seem to dance before the eyes of the beholder.



SAMIS
Fam. 1009

18 Arms Chandelier
Crystal Glass / Glossy Gold Plated
with Led lights
Ø 1550 mm H 1500 mm
Art. TF 9 CH / 18 AG IV / GOLD





SAMIS

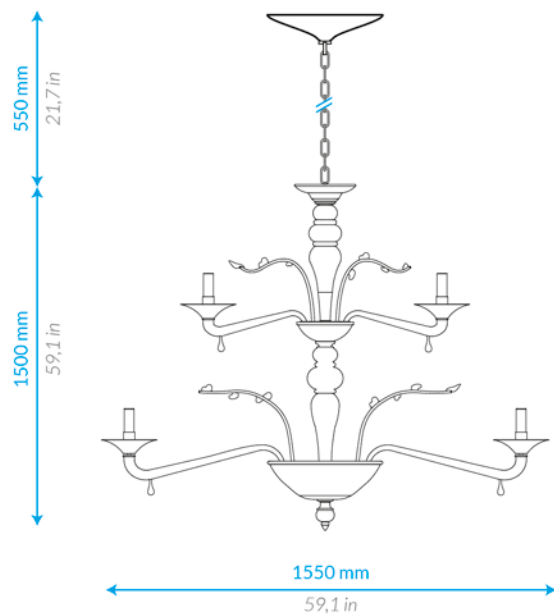

Lampadario 18 Bracci
18 Arms Chandelier

Item: **TF 1009 CH / 18**
Light Source: **LED 18 x 7,4 W**
Power: **133,2 W**
Voltage: **220 / 240 V** (110V Vers. USA)
Product Weight: **50 Kg / lbs 100**

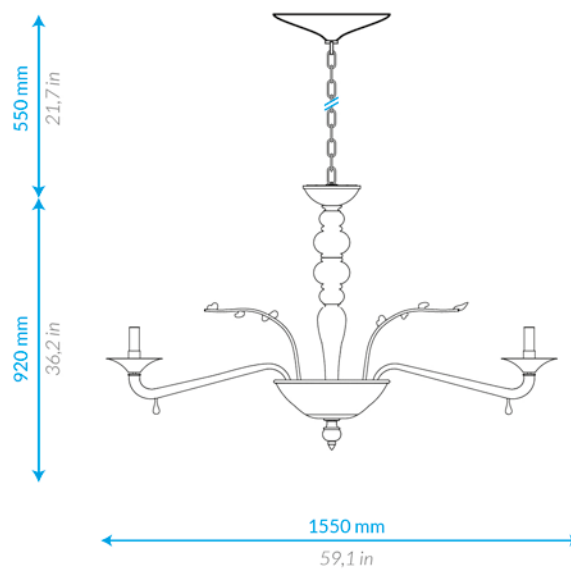

Lampadario 12 Bracci
12 Arms Chandelier

Item: **TF 1009 CH / 12**
Light Source: **LED 12 x 7,4 W**
Power: **88,8 W**
Voltage: **220 / 240 V** (110V Vers. USA)
Product Weight: **30 Kg / lbs 60**

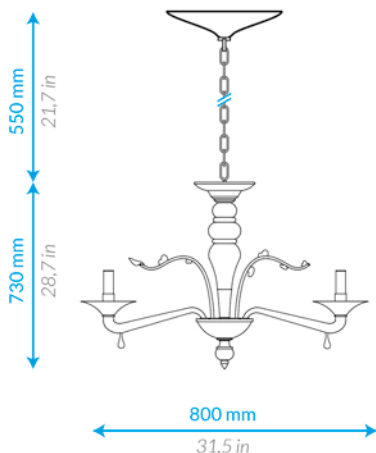

Lampadario 6 Bracci
6 Arms Chandelier

Item: **TF 1009 CH / 6**
 Light Source: **LED 6 x 7,4 W**
 Power: **44,4 W**
 Voltage: **220 / 240 V** (110V Vers. USA)
 Product Weight: **20 Kg / lbs 40**

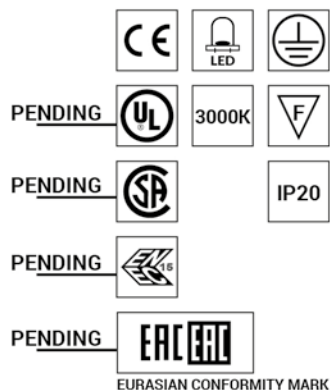

Disponibile in / Available in:

Colore Vetri / Glass Color

Trasparenti / Clear

CR	1	Cristallo Crystal	MA	7	Ametista Medio Medium Amethyst
MT	2	Topazio Medio Medium Topaz	DG	8	Grigio Grey
GG	3	Verde Erba Medio Medium Grass Green	CB	9	Blu Cobalto Cobalt Blue
MG	4	Verde Marino Chiaro Medium Marine Green	BL	10	Nero Black
DE	5	Verde Smeraldo Scuro Dark Emerald Green	MR	11	Rosso Medio Medium Red
DS	6	Acquamarina Scura Dark Sea Water			

Non Trasparenti / Solid

WM	12	Bianco White Milk	LG	18	Grigio Chiaro Light Grey
LG	13	Verde Pisello Light Green	IV	19	Avorio Ivory
NG	14	Verde Nilo Nile Green	PG	20	Grigio Perla Pearl Grey
BP	15	Pervinca Periwinkle	PP	21	Viola Purple
CS	16	Celeste Chiaro Clear Sky	PR	22	Rosso Porpora Chiaro Purple Red
DT	17	Turchese Scuro Dark Turquoise	DB	23	Marrone Scuro Dark Brown

Speciali / Special

LT GREY	29	Grigio Fumè Chiaro Smokey Light Grey	ST	35	Acciaio Trasp. Transp. Steel
DK GREY	30	Grigio Fumè Scuro Smokey Dark Grey	COR	36	Corniola Trasp. Transp. Carnelian
YEL	31	Giallo Limone Lemonish Yellow	AQUA	37	Acquamarina Trasp. Transp. Sea Water
VIOL	32	Violetto Violet	MC	38	Cristallo Specchiato Mirrored Crystal
GREY	33	Grigio Medio Medium Grey	GREEN	39	Verde Green
AM	34	Ametista Trasp. Transp. Amethyst			

Finiture /Finishing

A	Oro Lucido Glossy Gold Plated	G	Nero Opaco Matt Black RAL 9005
B	Cromo Lucido Glossy Chrome Plated	I	Bianco Opaco+Gomma Soft Matt White+Soft Rubber
C	Grigio Opaco Matt Grey RAL 7030	L	Ottone Brunito Burnished Brass
D	Beige Opaco Matt Beige RAL 1019	M	Acciaio Brunito Burnished Steel
E	Marrone Opaco Matt Brown RAL 8028	N	Bianco Verniciato White Painted
F	Bianco Opaco Matt White RAL 9003	O	Verniciatura Bronzo Bronze Painted

Lavorazioni /Techniques

PUL	PULEGOSO	RIG	RIGADIN
BAL	BALLOTON	SPIR	SPIRALE

DAMA ROSSA







Dama Rossa è un lussuoso lampadario in vetro di Murano. Le sue forme opulente, le volute e i bracci ampi, ne fanno un lampadario prezioso che trasporta chi lo possiede nelle atmosfere calde e festose dei palazzi signorili di un tempo. Dama rossa si distingue per la ricchezza degli elementi che lo compongono e la maestria infusa in ogni dettaglio.

Dama Rossa is a luxury chandelier in Murano glass. Its opulent shapes, the spirals and the wide arms, making it a precious chandelier that carries its possessor in the warm and festive atmosphere of palaces of the past. Its sufficient to notice the chandelier to understand how much consolidated craftsmanship is infused in every detail.



DAMA ROSSA
Fam. 1015

24 Arms Chandelier
Crystal Glass / Glossy Gold Plated / Medium Red
with Led lights
Ø 1700 mm H 1100 mm
Art. TF 1015 CH / 24 AG MR / GOLD







Fam. 1015

DAMA ROSSA

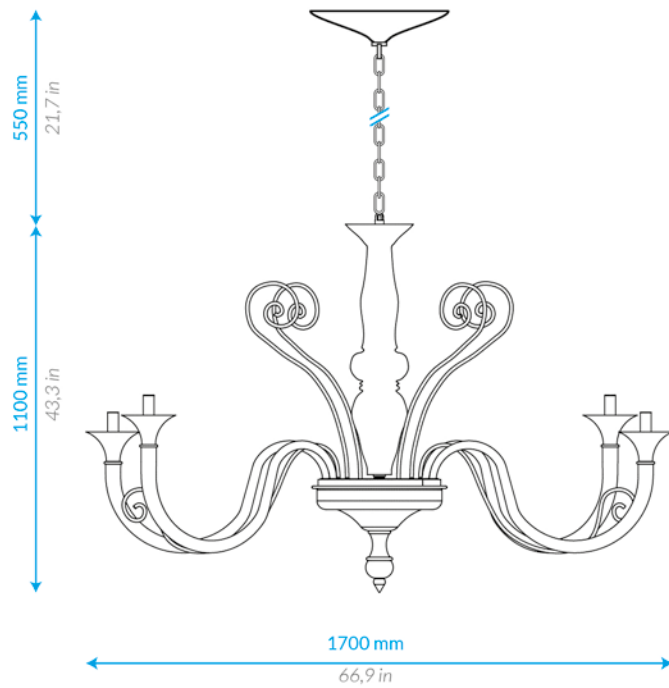

Lampadario 24 Bracci
24 Arms Chandelier

Item: **TF 1015 CH / 24**
Light Source: **LED 24 x 7,4 W**
Power: **177,6 W**
Voltage: **220 / 240 V** (110V Vers. USA)
Product Weight: **80 Kg / lbs 160**

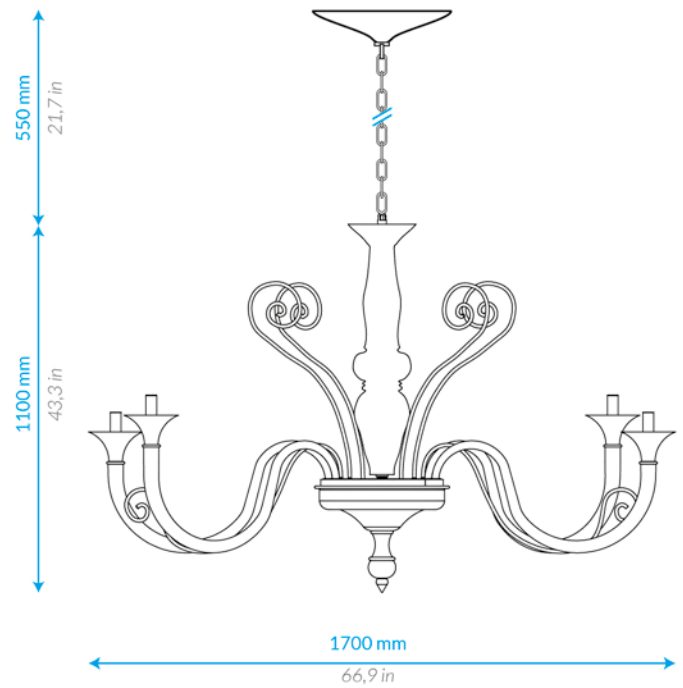

Lampadario 12 Bracci
12 Arms Chandelier

Item: **TF 1015 CH / 12**
Light Source: **LED 12 x 7,4 W**
Power: **88,8 W**
Voltage: **220 / 240 V** (110V Vers. USA)
Product Weight: **50 Kg / lbs 100**

Disponibile in / Available in:

Colore Vetri / Glass Color

Trasparenti / Clear

CR		1	Cristallo Crystal	MA		7	Ametista Medio Medium Amethyst
MT		2	Topazio Medio Medium Topaz	DG		8	Grigio Grey
GG		3	Verde Erba Medio Medium Grass Green	CB		9	Blu Cobalto Cobalt Blue
MG		4	Verde Marino Chiaro Medium Marine Green	BL		10	Nero Black
DE		5	Verde Smeraldo Scuro Dark Emerald Green	MR		11	Rosso Medio Medium Red
DS		6	Acquamarina Scura Dark Sea Water				

Non Trasparenti / Solid

WM		12	Bianco White Milk	LG		18	Grigio Chiaro Light Grey
LG		13	Verde Pisello Light Green	IV		19	Avorio Ivory
NG		14	Verde Nilo Nile Green	PG		20	Grigio Perla Pearl Grey
BP		15	Pervinca Periwinkle	PP		21	Viola Purple
CS		16	Celeste Chiaro Clear Sky	PR		22	Rosso Porpora Chiaro Purple Red
DT		17	Turchese Scuro Dark Turquoise	DB		23	Marrone Scuro Dark Brown

Speciali / Special

LT GREY		29	Grigio Fumè Chiaro Smokey Light Grey	ST		35	Acciaio Trasp. Transp. Steel
DK GREY		30	Grigio Fumè Scuro Smokey Dark Grey	COR		36	Corniola Trasp. Transp. Carnelian
YEL		31	Giallo Limone Lemonish Yellow	AQUA		37	Acquamarina Trasp. Transp. Sea Water
VIOL		32	Violetto Violet	MC		38	Cristallo Specchiato Mirrored Crystal
GREY		33	Grigio Medio Medium Grey	GREEN		39	Verde Green
AM		34	Ametista Trasp. Transp. Amethyst				

Finiture / Finishing

A		Oro Lucido Glossy Gold Plated	G		Nero Opaco Matt Black RAL 9005
B		Cromo Lucido Glossy Chrome Plated	I		Bianco Opaco+Gomma Soft Matt White+Soft Rubber
C		Grigio Opaco Matt Grey RAL 7030	L		Ottone Brunito Burnished Brass
D		Beige Opaco Matt Beige RAL 1019	M		Acciaio Brunito Burnished Steel
E		Marrone Opaco Matt Brown RAL 8028	N		Bianco Verniciato White Painted
F		Bianco Opaco Matt White RAL 9003	O		Verniciatura Bronzo Bronze Painted

Lavorazioni / Techniques

PUL		PULEGOSO	RIG		RIGADIN
BAL		BALLOTON	SPIR		SPIRALE

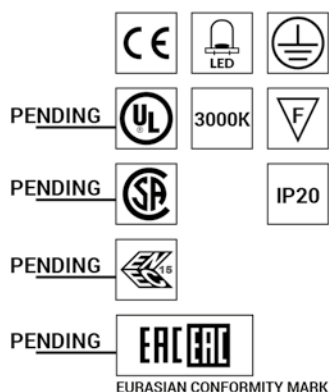

ALTIÈR







Altièr è un lampadario in vetro di Murano che riprende la tradizione antica e la semplifica, riducendo gli elementi decorativi e proponendo superfici essenziali. L'insieme rigoglioso, propone forme vegetali e fiammeggianti, che lo rendono elegante e allo stesso tempo brioso, classico e di design. I dettagli in oro, assieme agli elementi lavorati al rigadin impreziosiscono questo lampadario, in grado di conferire un'aura calda e familiare ad ogni spazio in cui si colloca.

Altièr is a chandelier in Murano glass that reflects the ancient tradition and simplifies, reducing decorative elements and surfaces offering the essentials. The whole of it, lush, offers blazing forms, making it stylish and at the same time lively, classic and of design.

The details in gold, the elements worked together in rigadin adorn this chandelier, can confer an aura warm and familiarity into any space it may be located in.



ALTIÉR
Fam. 1002

12 Arms Chandelier
Crystal Glass / Glossy Gold Plated
with Led lights
Ø 800 mm H 950 mm
Art. TF 1002 CH / 12





Fam. 1002

ALTIÈR

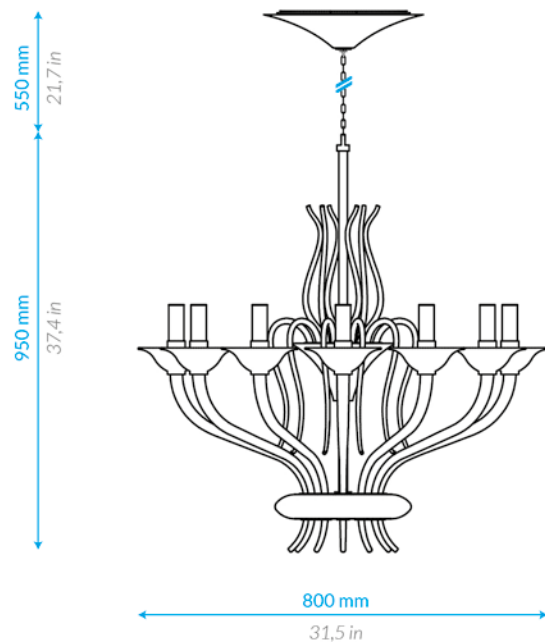

Lampadario 12 Bracci
12 Arms Chandelier

Item: **TF 1002 CH / 12**
Light Source: **LED 12 x 7,4 W**
Power: **88,8 W**
Voltage: **220 / 240 V** (110V Vers. USA)
Product Weight: **40 Kg / lbs 80**

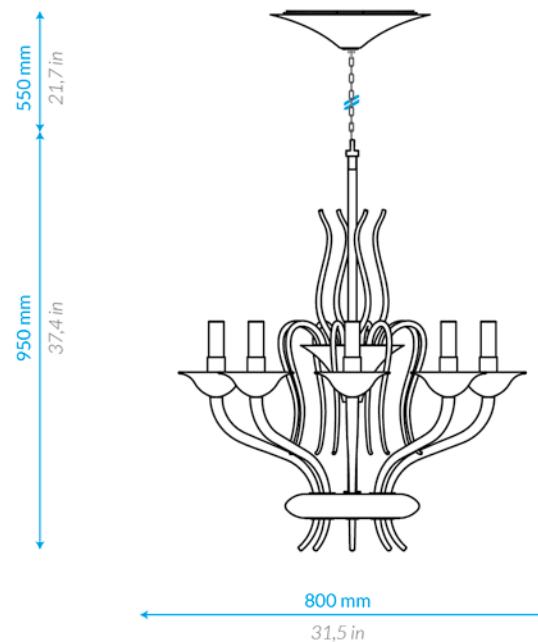

Lampadario 8 Bracci
8 Arms Chandelier

Item: **TF 1002 CH / 8**
Light Source: **LED 8 x 7,4 W**
Power: **59,2 W**
Voltage: **220 / 240 V** (110V Vers. USA)
Product Weight: **35 Kg / lbs 70**

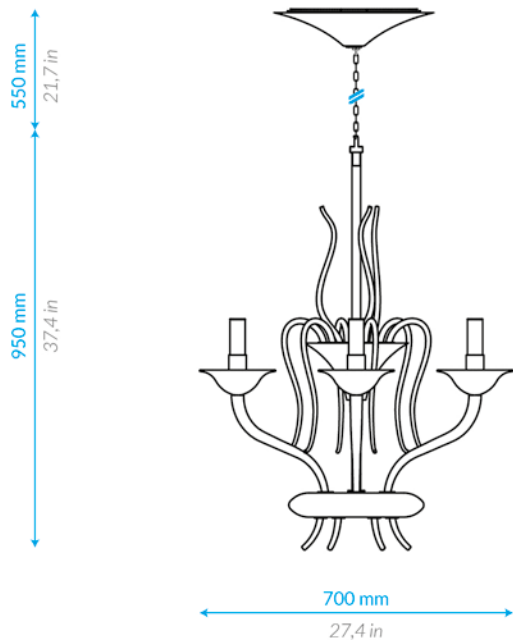

Lampadario 6 Bracci
6 Arms Chandelier

Item: **TF 1002 CH / 6**
 Light Source: **LED 6 x 7,4 W**
 Power: **44,4 W**
 Voltage: **220 / 240 V** (110V Vers. USA)
 Product Weight: **30 Kg / lbs 60**

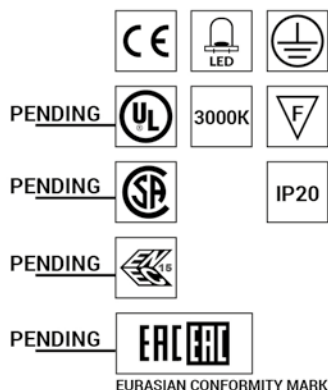

Disponibile in / Available in:

Colore Vetri / Glass Color

Trasparenti / Clear

CR	1	Cristallo Crystal	MA	7	Ametista Medio Medium Amethyst
MT	2	Topazio Medio Medium Topaz	DG	8	Grigio Grey
GG	3	Verde Erba Medio Medium Grass Green	CB	9	Blu Cobalto Cobalt Blue
MG	4	Verde Marino Chiaro Medium Marine Green	BL	10	Nero Black
DE	5	Verde Smeraldo Scuro Dark Emerald Green	MR	11	Rosso Medio Medium Red
DS	6	Acquamarina Scura Dark Sea Water			

Non Trasparenti / Solid

WM	12	Bianco White Milk	LG	18	Grigio Chiaro Light Grey
LG	13	Verde Pisello Light Green	IV	19	Avorio Ivory
NG	14	Verde Nilo Nile Green	PG	20	Grigio Perla Pearl Grey
BP	15	Pervinca Periwinkle	PP	21	Viola Purple
CS	16	Celeste Chiaro Clear Sky	PR	22	Rosso Porpora Chiaro Purple Red
DT	17	Turchese Scuro Dark Turquoise	DB	23	Marrone Scuro Dark Brown

Speciali / Special

LT GREY	29	Grigio Fumè Chiaro Smoky Light Grey	ST	35	Acciaio Trasp. Transp. Steel
DK GREY	30	Grigio Fumè Scuro Smoky Dark Grey	COR	36	Corniola Trasp. Transp. Carnelian
YEL	31	Giallo Limone Lemonish Yellow	AQUA	37	Acquamarina Trasp. Transp. Sea Water
VIOL	32	Violetto Violet	MC	38	Cristallo Specchiato Mirrored Crystal
GREY	33	Grigio Medio Medium Grey	GREEN	39	Verde Green
AM	34	Ametista Trasp. Transp. Amethyst			

Finiture /Finishing

A	Oro Lucido Glossy Gold Plated	G	Nero Opaco Matt Black RAL 9005
B	Cromo Lucido Glossy Chrome Plated	I	Bianco Opaco+Gomma Soft Matt White+Soft Rubber
C	Grigio Opaco Matt Grey RAL 7030	L	Ottone Brunito Burnished Brass
D	Beige Opaco Matt Beige RAL 1019	M	Acciaio Brunito Burnished Steel
E	Marrone Opaco Matt Brown RAL 8028	N	Bianco Verniciato White Painted
F	Bianco Opaco Matt White RAL 9003	O	Verniciatura Bronzo Bronze Painted

Lavorazioni /Techniques

PUL	PULEGOSO	RIG	RIGADIN
BAL	BALLOTON	SPIR	SPIRALE

CELESTIA







Celestia è un lampadario in vetro di Murano che conserva tutti i profumi della tradizione e li combina con le forme semplificate tipiche del design della prima metà del secolo scorso, quando le forme classiche venivano prosciugate in nome del funzionalismo, senza rinunciare all'eleganza. Il fusto centrale che alterna linee dritte e morbide, termina in un vaso conico dal quale si diramano bracci stretti e lunghi.

Celestia is a chandelier in Murano glass that preserves all the flavors of tradition and combines them with the simplified forms of the typical design of the first half of last century, when the classical forms were dried up in the name of functionalism, but did not want to give up yet a mannerism of elegance. It's central stem alternating straight lines and soft, ending in a conical vase from which branch off long narrow arms.



CELESTIA
Fam. 1001

Photo: 12 Arms Chandelier
Ivory Glass / Glossy Gold Plated
with Led lights
Ø 1200 mm H 800 mm
Art. TF 1001 CH / 12 IV / GOLD







CELESTIA
Fam. 1001

Photo: 12 Arms Chandelier
Ivory Glass / Glossy Gold Plated
Matt Brown RAL 8028 Fabric Lamp-shade
with Led lights
Ø 1200 mm H 800 mm
Art. TF 1001 CH / 12 IV / GOLD / L

MARTINA 1002

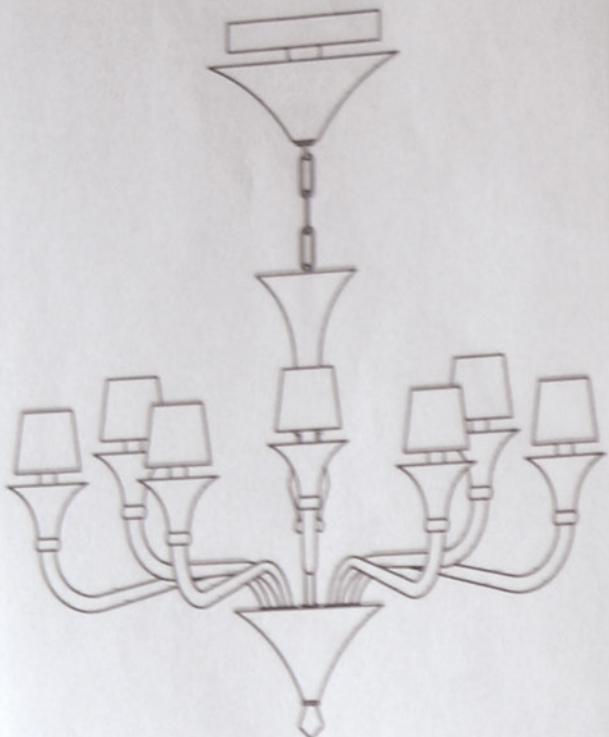

TECNICA LUMINOSA	
...	...
...	...
...	...

1002

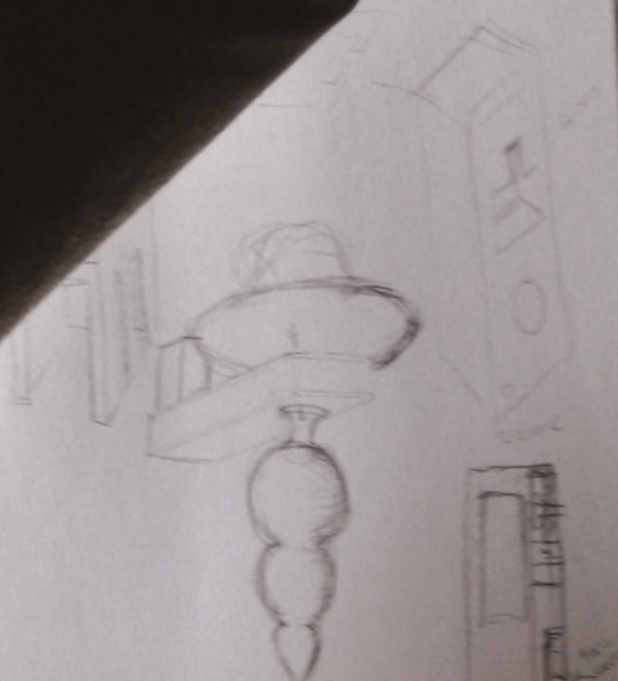



CELESTIA
Fam. 1001

Photo: 2 Lights Wall Lamp
Ivory Glass / Glossy Gold Plated
Matt Brown RAL 8028 Fabric Lamp-shade
with Led lights
B 500 mm H 350 mm
Art. TF 1001 WS / 2 IV / GOLD / L





CELESTIA
Fam 1001

Photo: Table Lamp
Ivory Glass / Glossy Gold Plated
with Led lights
Ø 240 mm H 370 mm
Art. TF 1001 TL / 1 IV / GOLD



CELESTIA

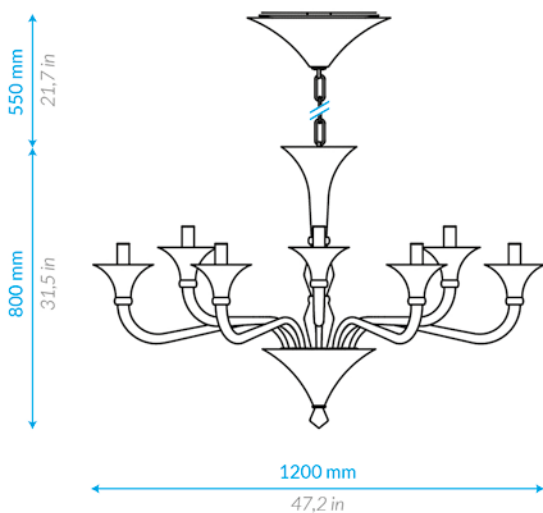

Lampadario 12 Bracci
12 Arms Chandelier

Item: **TF 1001 CH / 12**
 Light Source: **LED 12 x 7,4 W + 3 x 1,4 W**
 Power: **93 W**
 Voltage: **220 / 240 V** (110V Vers. USA)
 Product Weight: **35 Kg / lbs 70**

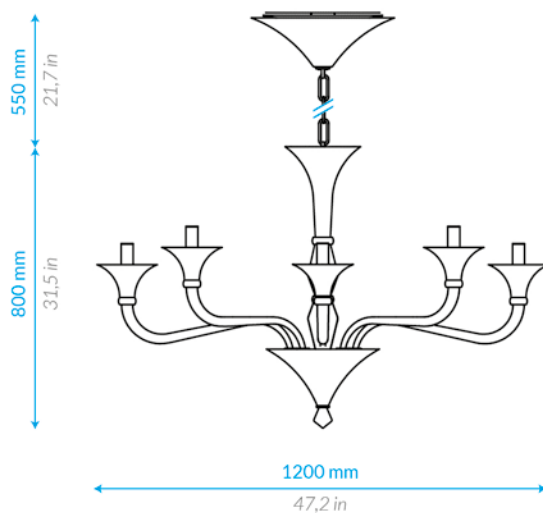

Lampadario 8 Bracci
8 Arms Chandelier

Item: **TF 1001 CH / 8**
 Light Source: **LED 8 x 7,4 W + 3 x 1,4 W**
 Power: **63,4 W**
 Voltage: **220 / 240 V** (110V Vers. USA)
 Product Weight: **28 Kg / lbs 56**

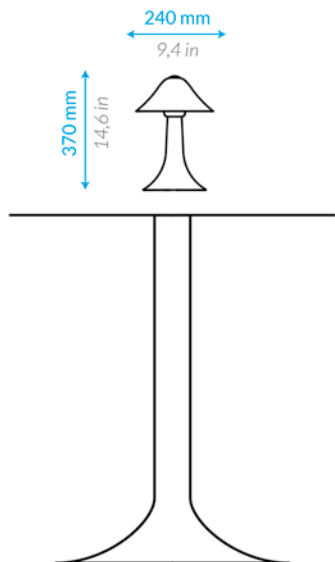

Lampada da Tavolo
Table Lamp

Item: **TF 1001 TL / 1**
 Light Source: **E14 socket bulb**
 Power: **max 46 W (HSG)**
 Voltage: **220 / 240 V** (110V Vers. USA)
 Product Weight: **2 Kg / lbs 4**

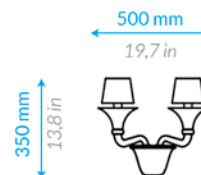

Applique 2 Bracci
8 Lights Wall Lamp

Item: **TF 1001 WS / 2**
 Light Source: **LED 2 x 7,4 W**
 Power: **14,8 W**
 Voltage: **220 / 240 V** (110V Vers. USA)
 Product Weight: **10 Kg / lbs 10**

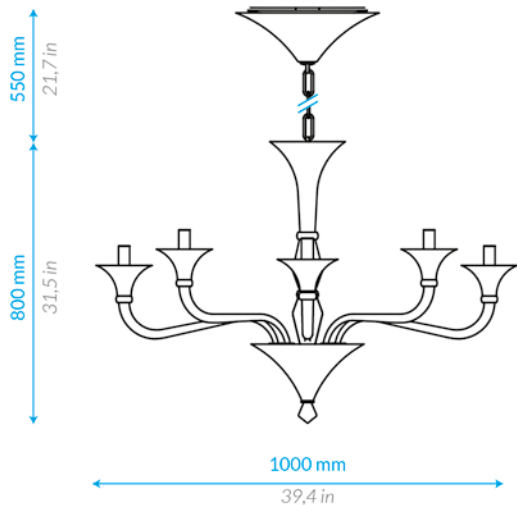

Lampadario 6 Bracci 6 Arms Chandelier

Item: **TF 1001 CH / 6**
 Light Source: **LED 6 x 7,4 W + 3 x 1,4 W**
 Power: **48,6 W**
 Voltage: **220 / 240 V** (110V Vers. USA)
 Product Weight: **23 Kg / lbs 46**

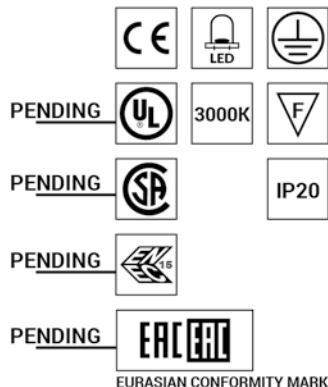

Disponibile in / Available in:

Colore Vetri / Glass Color

Trasparenti / Clear

CR	1	Cristallo Crystal	MA	7	Ametista Medio Medium Amethyst
MT	2	Topazio Medio Medium Topaz	DG	8	Grigio Grey
GG	3	Verde Erba Medio Medium Grass Green	CB	9	Blu Cobalto Cobalt Blue
MG	4	Verde Marino Chiaro Medium Marine Green	BL	10	Nero Black
DE	5	Verde Smeraldo Scuro Dark Emerald Green	MR	11	Rosso Medio Medium Red
DS	6	Acquamarina Scura Dark Sea Water			

Non Trasparenti / Solid

WM	12	Bianco White Milk	LG	18	Grigio Chiaro Light Grey
LG	13	Verde Pisello Light Green	IV	19	Avorio Ivory
NG	14	Verde Nilo Nile Green	PG	20	Grigio Perla Pearl Grey
BP	15	Pervinca Periwinkle	PP	21	Viola Purple
CS	16	Celeste Chiaro Clear Sky	PR	22	Rosso Porpora Chiaro Purple Red
DT	17	Turchese Scuro Dark Turquoise	DB	23	Marrone Scuro Dark Brown

Speciali / Special

LT GREY	29	Grigio Fumè Chiaro Smokey Light Grey	ST	35	Acciaio Trasp. Transp. Steel
DK GREY	30	Grigio Fumè Scuro Smokey Dark Grey	COR	36	Corniola Trasp. Transp. Carnelian
YEL	31	Giallo Limone Lemonish Yellow	AQUA	37	Acquamarina Trasp. Transp. Sea Water
VIOL	32	Violetto Violet	MC	38	Cristallo Specchiato Mirrored Crystal
GREY	33	Grigio Medio Medium Grey	GREEN	39	Verde Green
AM	34	Ametista Trasp. Transp. Amethyst			

Finiture /Finishing

A	Oro Lucido Glossy Gold Plated	G	Nero Opaco Matt Black RAL 9005
B	Cromo Lucido Glossy Chrome Plated	I	Bianco Opaco+Gomma Soft Matt White+Soft Rubber
C	Grigio Opaco Matt Grey RAL 7030	L	Ottone Brunito Burnished Brass
D	Beige Opaco Matt Beige RAL 1019	M	Acciaio Brunito Burnished Steel
E	Marrone Opaco Matt Brown RAL 8028	N	Bianco Verniciato White Painted
F	Bianco Opaco Matt White RAL 9003	O	Verniciatura Bronzo Bronze Painted

Lavorazioni /Techniques

PUL	PULEGOSO	RIG	RIGADIN
BAL	BALLOTON	SPIR	SPIRALE

CAMOPÌNA







Camopina è il termine veneziano per definire l'Equiseto dei campi, *Equisetum Arvense*, una pianta erbacea perenne appartenente alla famiglia delle Equisetaceae.

Le sue linee lievi e lineari lo rendono indiscutibilmente adatto ad ambienti ed arredi molto diversi tra loro. Camopina esiste in tipologie da 12, 9 e 6 bracci.

*Camopina is the Venetian term to define horsetail fields, *Equisetum arvense*, a perennial herb in the Equisetaceae family.*

Its mild and linear lines make it unquestionably suited to very different environments and furniture. Camopina exists in types 12, 9 and 6 arms.



CAMOPINA
Fam. 1010

Photo: 9 Arms Chandelier
Chystal Grey Glass / Glossy Chrome Plated
with Led lights
Ø 1100 mm H 660 mm
Art. TF 1010 CH / 9 DG / CR / CHROME





Fam. 1010

CAMOPINA

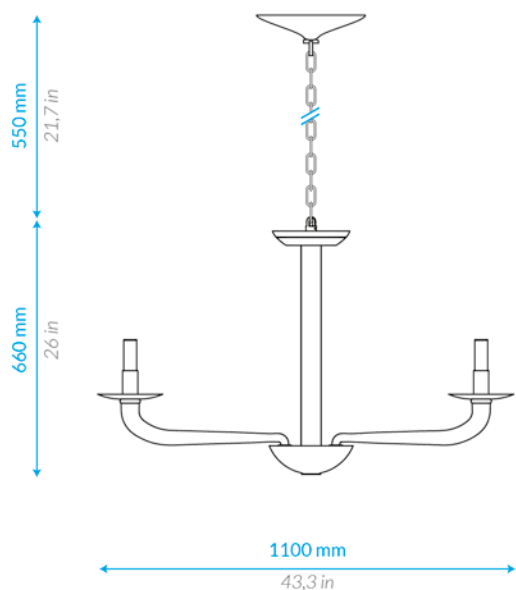

Lampadario 12 Bracci
12 Arms Chandelier

Item: **TF 1010 CH / 12**
Light Source: **LED 12 x 7,4 W + 6 x 1,4 W**
Power: **97,2 W**
Voltage: **220 / 240 V** (110V Vers. USA)
Product Weight: **30 Kg / lbs 60**

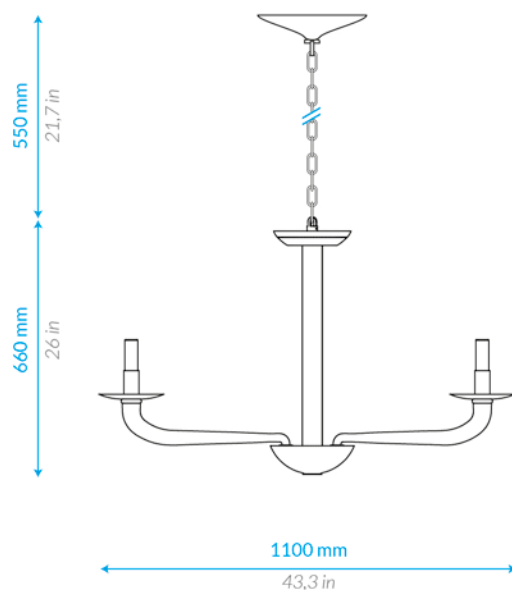

Lampadario 9 Bracci
9 Arms Chandelier

Item: **TF 1010 CH / 9**
Light Source: **LED 9 x 7,4 W + 6 x 1,4 W**
Power: **75 W**
Voltage: **220 / 240 V** (110V Vers. USA)
Product Weight: **25 Kg / lbs 50**

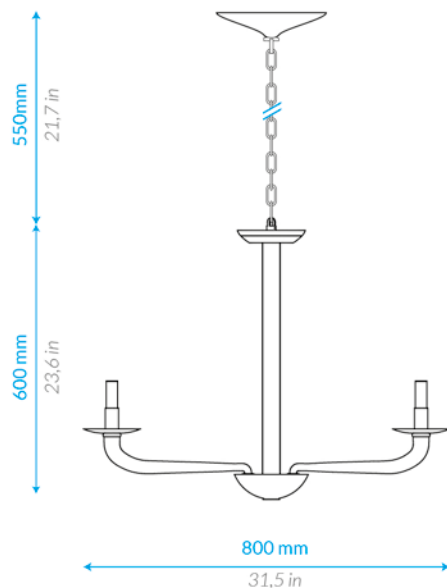

Lampadario 6 Bracci 6 Arms Chandelier

Item: **TF 1010 CH / 6**

Light Source: **LED 6 x 7,4 W + 6 x 1,4 W**

Power: **52,8 W**

Voltage: **220 / 240 V** (110V Vers. USA)

Product Weight: **20 Kg / lbs 40**

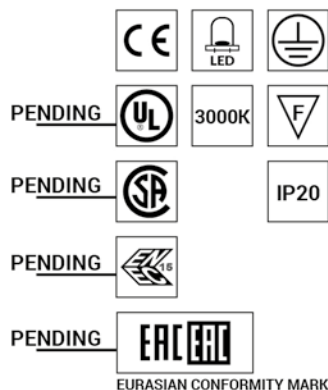

Disponibile in / Available in:

Colore Vetri / Glass Color

Trasparenti / Clear

CR	1	Cristallo Crystal	MA	7	Ametista Medio Medium Amethyst
MT	2	Topazio Medio Medium Topaz	DG	8	Grigio Grey
GG	3	Verde Erba Medio Medium Grass Green	CB	9	Blu Cobalto Cobalt Blue
MG	4	Verde Marino Chiaro Medium Marine Green	BL	10	Nero Black
DE	5	Verde Smeraldo Scuro Dark Emerald Green	MR	11	Rosso Medio Medium Red
DS	6	Acquamarina Scura Dark Sea Water			

Non Trasparenti / Solid

WM	12	Bianco White Milk	LG	18	Grigio Chiaro Light Grey
LG	13	Verde Pisello Light Green	IV	19	Avorio Ivory
NG	14	Verde Nilo Nile Green	PG	20	Grigio Perla Pearl Grey
BP	15	Pervinca Periwinkle	PP	21	Viola Purple
CS	16	Celeste Chiaro Clear Sky	PR	22	Rosso Porpora Chiaro Purple Red
DT	17	Turchese Scuro Dark Turquoise	DB	23	Marrone Scuro Dark Brown

Speciali / Special

LT GREY	29	Grigio Fumè Chiaro Smokey Light Grey	ST	35	Acciaio Trasp. Transp. Steel
DK GREY	30	Grigio Fumè Scuro Smokey Dark Grey	COR	36	Corniola Trasp. Transp. Carnelian
YEL	31	Giallo Limone Lemonish Yellow	AQUA	37	Acquamarina Trasp. Transp. Sea Water
VIOL	32	Violetto Violet	MC	38	Cristallo Specchiato Mirrored Crystal
GREY	33	Grigio Medio Medium Grey	GREEN	39	Verde Green
AM	34	Ametista Trasp. Transp. Amethyst			

Finiture /Finishing

A	Oro Lucido Glossy Gold Plated	G	Nero Opaco Matt Black RAL 9005
B	Cromo Lucido Glossy Chrome Plated	I	Bianco Opaco+Gomma Soft Matt White+Soft Rubber
C	Grigio Opaco Matt Grey RAL 7030	L	Ottone Brunito Burnished Brass
D	Beige Opaco Matt Beige RAL 1019	M	Acciaio Brunito Burnished Steel
E	Marrone Opaco Matt Brown RAL 8028	N	Bianco Verniciato White Painted
F	Bianco Opaco Matt White RAL 9003	O	Verniciatura Bronzo Bronze Painted

Lavorazioni /Techniques

PUL	PULEGOSO	RIG	RIGADIN
BAL	BALLOTON	SPIR	SPIRALE

FADÀ







Fadà è il nome scelto per questo splendido lampadario in vetro di Murano. Il suo nome, dal veneziano, significa fatato. Fadà riprende la tradizione del lampadario classico a doppio palco, semplificandolo e conferendogli un tocco di fatata effervescenza. Dall'alto scende un fusto centrale lungo e sottile, interrotto da un elemento circolare, dai cui pinnacoli, i bracci si diramano con la stessa leggerezza di un tessuto sollevato dal vento.

Fadà is the name chosen for this beautiful chandelier made in Murano glass. His name, in Venetian, means fairy. Fadà revives the tradition of the classic dual stage chandelier, simplifying it and giving it a touch of fairy effervescence. It descends from a central stem, long and thin, interrupted by a circular element, from whose pinnacles, the arms branch out with the same lightness of fabric lifted by the wind.



FADÀ
Fam. 1010

Photo: 8 Arms Chandelier
Pearl Grey Glass / Glossy Chrome Plated
with Led lights
Ø 1200 mm H 950 mm
Art. TF 1012 CH / 8 DG/ CHROME

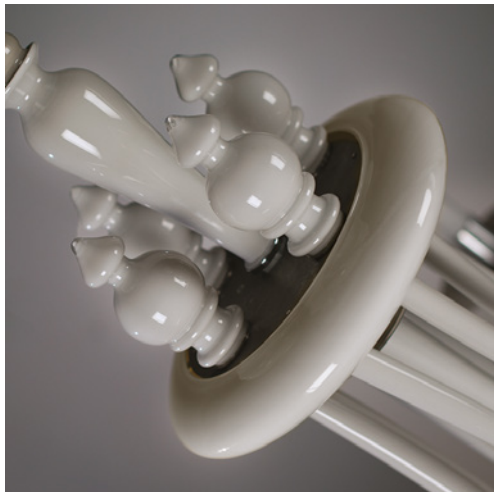





Fam. 1012

FADÀ

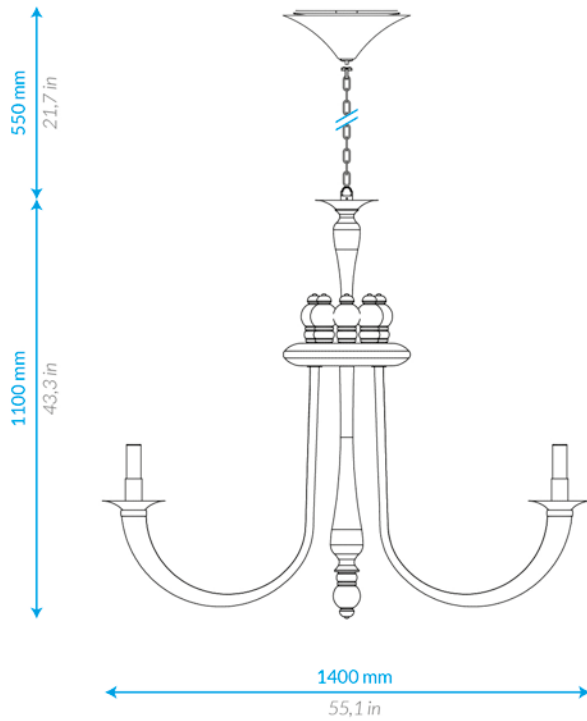

Lampadario 12 Bracci 12 Arms Chandelier

Item: **TF 1012 CH / 12**
Light Source: **LED 12 x 7,4 W + 6 x 1,4 W**
Power: **97,2 W**
Voltage: **220 / 240 V** (110V Vers. USA)
Product Weight: **35 Kg / lbs 70**

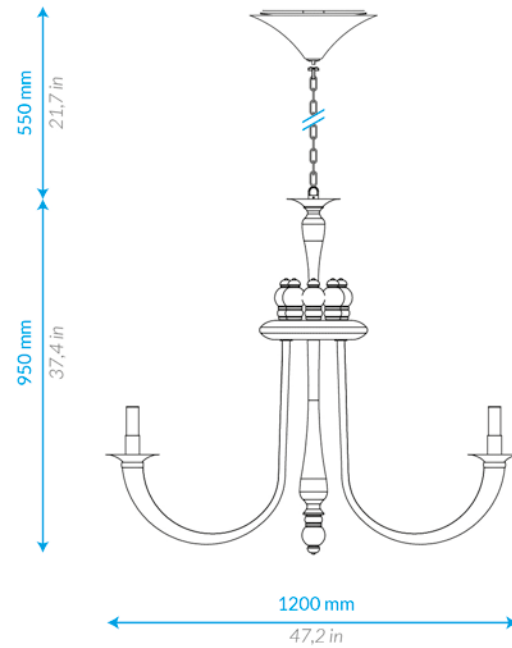

Lampadario 8 Bracci 8 Arms Chandelier

Item: **TF 1012 CH / 8**
Light Source: **LED 8 x 7,4 W + 4 x 1,4 W**
Power: **64,8 W**
Voltage: **220 / 240 V** (110V Vers. USA)
Product Weight: **25 Kg / lbs 50**

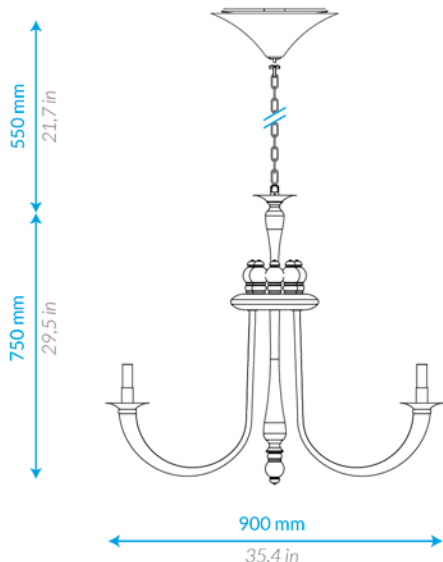

Lampadario 6 Bracci
6 Arms Chandelier

Item: **TF 1012 CH / 8**

Light Source: **LED 8 x 7,4 W + 4 x 1,4 W**

Power: **64,8 W**

Voltage: **220 / 240 V** (110V Vers. USA)

Product Weight: **25 Kg / lbs 50**

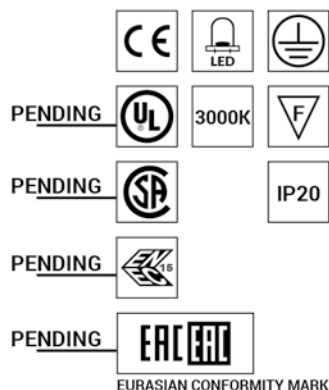

Disponibile in / Available in:

Colore Vetri / Glass Color

Trasparenti / Clear

CR	1	Cristallo Crystal	MA	7	Ametista Medio Medium Amethyst
MT	2	Topazio Medio Medium Topaz	DG	8	Grigio Grey
GG	3	Verde Erba Medio Medium Grass Green	CB	9	Blu Cobalto Cobalt Blue
MG	4	Verde Marino Chiaro Medium Marine Green	BL	10	Nero Black
DE	5	Verde Smeraldo Scuro Dark Emerald Green	MR	11	Rosso Medio Medium Red
DS	6	Acquamarina Scura Dark Sea Water			

Non Trasparenti / Solid

WM	12	Bianco White Milk	LG	18	Grigio Chiaro Light Grey
LG	13	Verde Pisello Light Green	IV	19	Avorio Ivory
NG	14	Verde Nilo Nile Green	PG	20	Grigio Perla Pearl Grey
BP	15	Pervinca Periwinkle	PP	21	Viola Purple
CS	16	Celeste Chiaro Clear Sky	PR	22	Rosso Porpora Chiaro Purple Red
DT	17	Turchese Scuro Dark Turquoise	DB	23	Marrone Scuro Dark Brown

Speciali / Special

LT GREY	29	Grigio Fumè Chiaro Smokey Light Grey	ST	35	Acciaio Trasp. Transp. Steel
DK GREY	30	Grigio Fumè Scuro Smokey Dark Grey	COR	36	Corniola Trasp. Transp. Carnelian
YEL	31	Giallo Limone Lemonish Yellow	AQUA	37	Acquamarina Trasp. Transp. Sea Water
VIOL	32	Violetto Violet	MC	38	Cristallo Specchiato Mirrored Crystal
GREY	33	Grigio Medio Medium Grey	GREEN	39	Verde Green
AM	34	Ametista Trasp. Transp. Amethyst			

Finiture /Finishing

A	Oro Lucido Glossy Gold Plated	G	Nero Opaco Matt Black RAL 9005
B	Cromo Lucido Glossy Chrome Plated	I	Bianco Opaco+Gomma Soft Matt White+Soft Rubber
C	Grigio Opaco Matt Grey RAL 7030	L	Ottone Brunito Burnished Brass
D	Beige Opaco Matt Beige RAL 1019	M	Acciaio Brunito Burnished Steel
E	Marrone Opaco Matt Brown RAL 8028	N	Bianco Verniciato White Painted
F	Bianco Opaco Matt White RAL 9003	O	Verniciatura Bronzo Bronze Painted

Lavorazioni /Techniques

PUL	PULEGOSO	RIG	RIGADIN
BAL	BALLOTON	SPIR	SPIRALE

CONCA







Conca è un elegante lampadario in vetro di Murano che ripropone con grazia e garbo le linee del lampadario classico, prosciugandole dagli eccessi ed interpretandole secondo un design moderno e allegro.

Il fusto centrale alterna linee rigide e tonde fino ad esplodere nella florida semisfera, appunto la conca, dalla quale si diramano i bracci che dapprima esili, si inspessiscono fino alla accogliente tazza.

L'architettura finale risulta rigorosa e allo stesso tempo leggera e vivace.

Conca is an elegant chandelier in Murano glass with grace and politeness that proposes the lines of the classic chandelier, resulting in dry excesses and interpreting them in a contemporary design and in a more cheerful manner. The entire apparatus is played on the softness and fluidity. It's central stem alternates rigid lines and rounds up until they explode in the thriving hemisphere created, just the basin, from which branch off the arms that first thin, thicken up the welcoming cup. The final architecture is rigorous and at the same time light and lively.

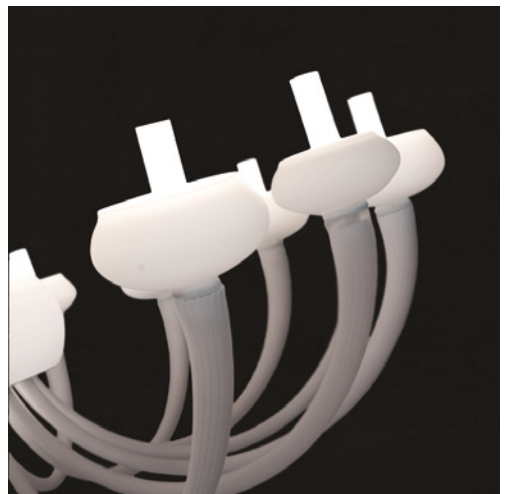





CONCA
Fam. 1011

Photo: 8 Arms Chandelier
White Milk Glass / Matt White Painted RAL 9003
with Led lights
Ø 970 mm H 750 mm
Art. TF 1011 CH / 8 WM / WHITE

CONCA

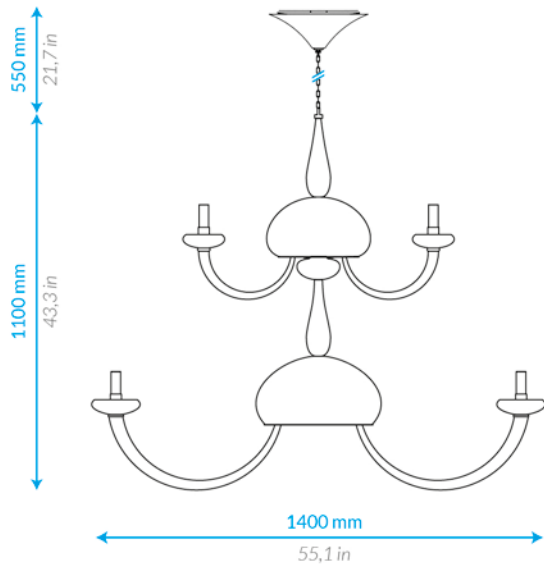

Lampadario 24 Bracci
24 Arms Chandelier

Item: **TF 1011 CH / 24**
Light Source: **LED 24 x 7,4 W + 24 x 1,4 W**
Power: **211 W**
Voltage: **220 / 240 V** (110V Vers. USA)
Product Weight: **70 Kg** / lbs 140

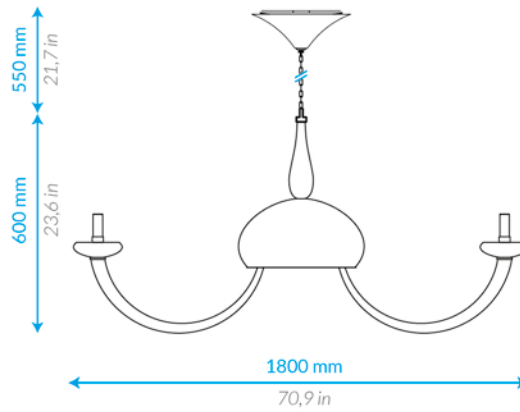

Lampadario 16 Bracci
16 Arms Chandelier

Item: **TF 1011 CH / 16**
Light Source: **LED 16 x 7,4 W + 12 x 1,4 W**
Power: **135,2 W**
Voltage: **220 / 240 V** (110V Vers. USA)
Product Weight: **45 Kg** / lbs 90

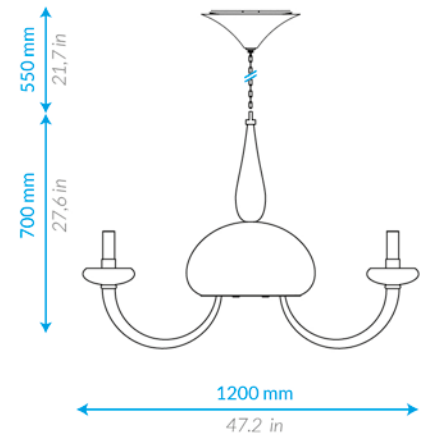

Lampadario 12 Bracci
12 Arms Chandelier

Item: **TF 1011 CH / 12**
Light Source: **LED 12 x 7,4 W + 12 x 1,4 W**
Power: **105,6 W**
Voltage: **220 / 240 V** (110V Vers. USA)
Product Weight: **30 Kg** / lbs 60

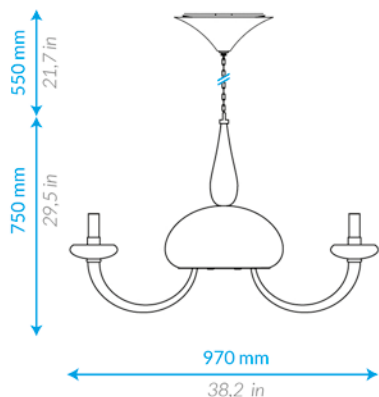

Lampadario 8 Bracci 8 Arms Chandelier

Item: **TF 1011 CH / 8**

Light Source: **LED 8 x 7,4 W + 12 x 1,4 W**

Power: **76 W**

Voltage: **220 / 240 V** (110V Vers. USA)

Product Weight: **25 Kg / lbs 50**

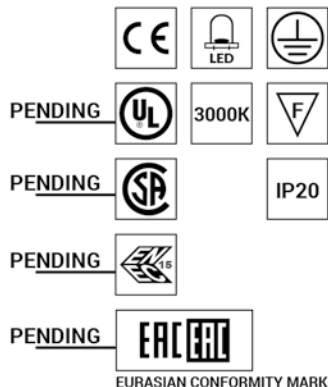

Disponibile in / Available in:

Colore Vetri / Glass Color

Trasparenti / Clear

CR	1	Cristallo Crystal	MA	7	Ametista Medio Medium Amethyst
MT	2	Topazio Medio Medium Topaz	DG	8	Grigio Grey
GG	3	Verde Erba Medio Medium Grass Green	CB	9	Blu Cobalto Cobalt Blue
MG	4	Verde Marino Chiaro Medium Marine Green	BL	10	Nero Black
DE	5	Verde Smeraldo Scuro Dark Emerald Green	MR	11	Rosso Medio Medium Red
DS	6	Acquamarina Scura Dark Sea Water			

Non Trasparenti / Solid

WM	12	Bianco White Milk	LG	18	Grigio Chiaro Light Grey
LG	13	Verde Pisello Light Green	IV	19	Avorio Ivory
NG	14	Verde Nilo Nile Green	PG	20	Grigio Perla Pearl Grey
BP	15	Pervinca Periwinkle	PP	21	Viola Purple
CS	16	Celeste Chiaro Clear Sky	PR	22	Rosso Porpora Chiaro Purple Red
DT	17	Turchese Scuro Dark Turquoise	DB	23	Marrone Scuro Dark Brown

Speciali / Special

LT GREY	29	Grigio Fumè Chiaro Smokey Light Grey	ST	35	Acciaio Trasp. Transp. Steel
DK GREY	30	Grigio Fumè Scuro Smokey Dark Grey	COR	36	Corniola Trasp. Transp. Carnelian
YEL	31	Giallo Limone Lemonish Yellow	AQUA	37	Acquamarina Trasp. Transp. Sea Water
VIOL	32	Violetto Violet	MC	38	Cristallo Specchiato Mirrored Crystal
GREY	33	Grigio Medio Medium Grey	GREEN	39	Verde Green
AM	34	Ametista Trasp. Transp. Amethyst			

Finiture / Finishing

A	Oro Lucido Glossy Gold Plated	G	Nero Opaco Matt Black RAL 9005
B	Cromo Lucido Glossy Chrome Plated	I	Bianco Opaco+Gomma Soft Matt White+Soft Rubber
C	Grigio Opaco Matt Grey RAL 7030	L	Ottone Brunito Burnished Brass
D	Beige Opaco Matt Beige RAL 1019	M	Acciaio Brunito Burnished Steel
E	Marrone Opaco Matt Brown RAL 8028	N	Bianco Verniciato White Painted
F	Bianco Opaco Matt White RAL 9003	O	Verniciatura Bronzo Bronze Painted

Lavorazioni / Techniques

PUL	PULEGOSO	RIG	RIGADIN
BAL	BALLOTON	SPIR	SPIRALE

CASTELLO





Castello è un lampadario esclusivo che guarda agli antichi sistemi di illuminazione e li trasporta nella contemporaneità, rendendoli eleganti oltre che raffinati. La struttura circolare, tipica dei lampadari che nella tardo antichità illuminavano castelli e maestose basiliche, è realizzata in metallo; le candele moderne sono luci a led incastonate in preziosi pinnacoli, vere sculturine, realizzate una ad una con tutta la maestria del vetro di Murano, e dunque uniche.

Castello is a unique chandelier that looks at ancient lighting systems and transports them in the contemporary world as well as making them elegant and refined. The circular structure, typical of the chandeliers in the late antiquity lit majestic castles and basilicas, is made of metal; candles are modern led lights embedded in precious pinnacles, true figurines, made one by one with all the mastery of Murano glass, therefore making them unique.



CASTELLO
Fam. 1006

Photo: 24 Lights Chandelier
Ivory Glass / Matt Beige RAL 1019
with Led lights
Ø 1300 mm H 1500 mm
Art. TF 1006 CH / 24 IV / BEIGE

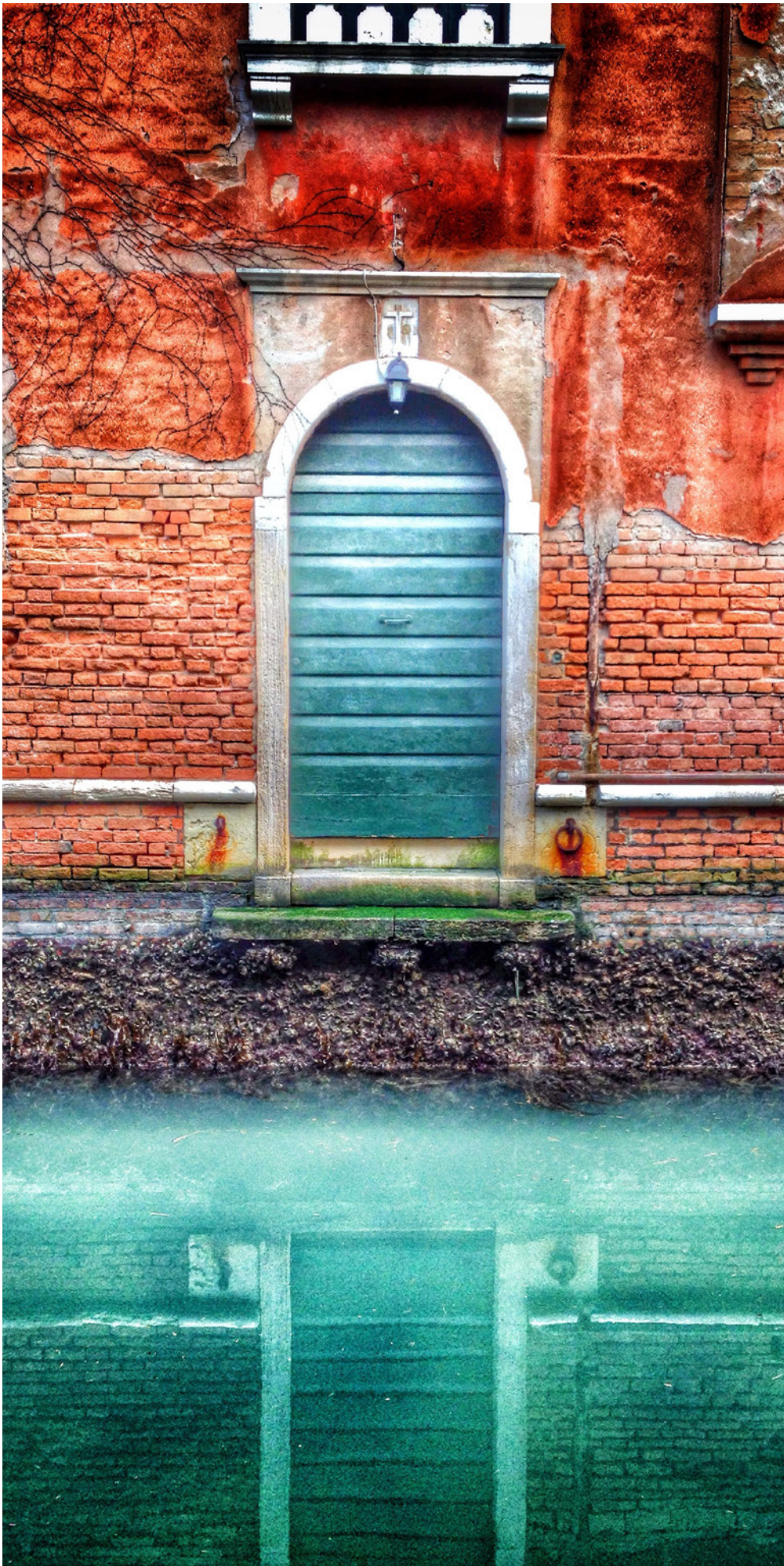



CASTELLO
Fam. 1006

Photo: 8 Lights Chandelier
Ivory Glass / Matt Beige RAL 1019
with Led lights
Ø 1300 mm H 1500 mm
Art. TF 1006 CH / 24 IV / BEIGE



CASTELLO
Fam. 1006

Photo: 1 Light Wall Lamp
Ivory Glass / Matt Beige RAL 1019
with Led lights
Ø 240 mm H 390 mm
Art. TF 1006 WS / 1 IV / BEIGE

▼ CASTELLO
Fam. 1006

Photo: 3 Light Wall Lamp
Ivory Glass / Matt Beige RAL 1019
with Led lights
Ø 240 mm H 390 mm
Art. TF 1006 WS / 3 IV / M / BEIGE



CASTELLO ▼
Fam. 1006

Photo: 5 Light Wall Lamp
Ivory Glass / Matt Beige RAL 1019
with Led lights
Ø 240 mm H 390 mm
Art. TF 1006 WS / 5 IV / M / BEIGE







CASTELLO
Fam. 1006

Photo: 1 Light Suspension Lamp
Ivory Glass / Matt Beige RAL 1019
with Led lights
Ø 160 mm H 335 mm
Art. TF 1006 SU / 1 IV / G / BEIGE

CASTELLO

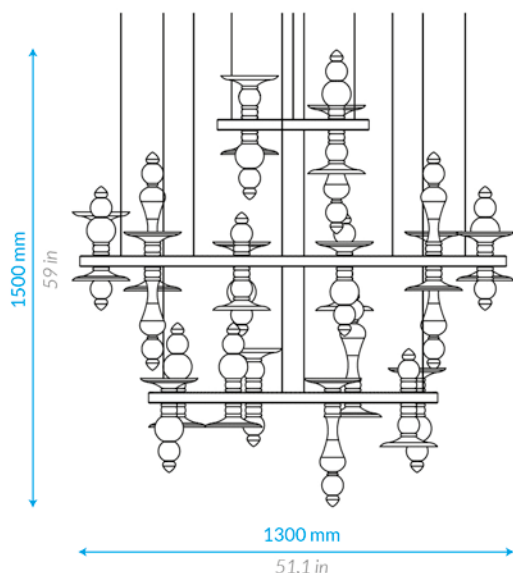

Lampadario 24 Luci
24 Lights Chandelier

Item: **TF 1006 CH / 24**
 Light Source: **LED 24 x 5,4 W + 24 x 1,3 W**
 Power: **160,8 W**
 Voltage: **220 / 240 V** (110V Vers. USA)
 Product Weight: **35 Kg / lbs 70**

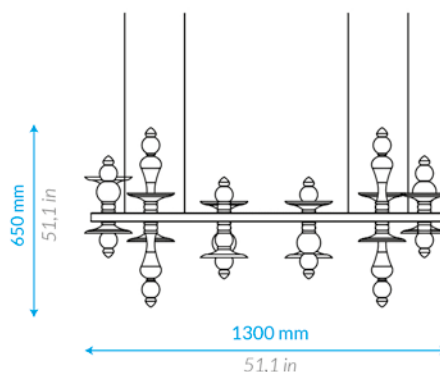

Lampadario 12 Luci
12 Lights Chandelier

Item: **TF 1006 CH / 12**
 Light Source: **LED 12 x 5,4 W + 12 x 1,3 W**
 Power: **80,4 W**
 Voltage: **220 / 240 V** (110V Vers. USA)
 Product Weight: **20 Kg / lbs 40**

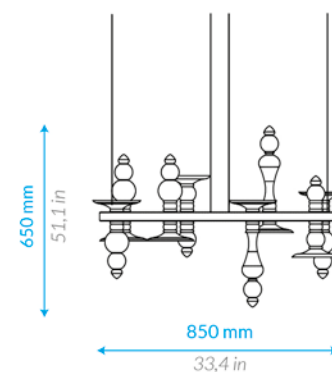

Lampadario 8 Luci
8 Lights Chandelier

Item: **TF 1006 CH / 8**
 Light Source: **LED 8 x 5,4 W + 8 x 1,3 W**
 Power: **53,6 W**
 Voltage: **220 / 240 V** (110V Vers. USA)
 Product Weight: **10 Kg / lbs 20**

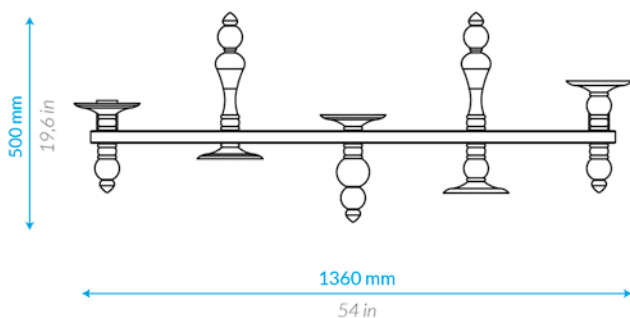

Applique 5 Luci
5 Lights Wall Lamp

Item: **TF 1006 CH / 5**
 Light Source: **LED 5 x 5,4 W + 5 x 1,3 W**
 Power: **33,5 W**
 Voltage: **220 / 240 V** (110V Vers. USA)
 Product Weight: **7 Kg / lbs 14**

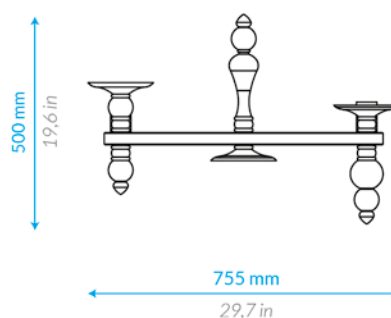

Applique 3 Luci
3 Lights Wall Lamp

Item: **TF 1006 CH / 3**
 Light Source: **LED 3 x 5,4 W + 3 x 1,4 W**
 Power: **20,1 W**
 Voltage: **220 / 240 V** (110V Vers. USA)
 Product Weight: **4 Kg / lbs 7**

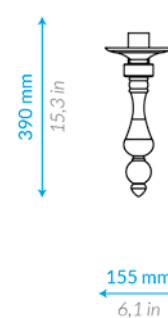

Applique 1 Luce
1 Light Wall Lamp

Item: **TF 1006 WS / 1**
 Light Source: **LED 1 x 9,3 W + 1 x 2,2 W**
 Power: **11,5 W**
 Voltage: **220 / 240 V** (110V Vers. USA)
 Product Weight: **2,5 Kg / lbs 5**

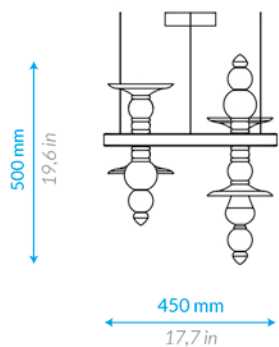

Lampadario 4 Luci 4 Lights Chandelier

Item: **TF 1006 CH / 4**
 Light Source: **LED 4 x 5,4 W + 4 x 1,3 W**
 Power: **26,8 W**
 Voltage: **220 / 240 V** (110V Vers. USA)
 Product Weight: **7 Kg / lbs 14**

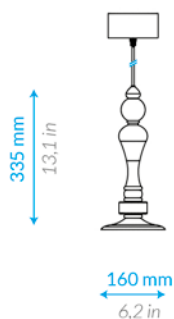

Sospensione 1 luce 1 Light Suspension Lamp

Item: **TF 1006 SU / 1**
 Light Source: **LED modules**
 Power: **9,3 W**
 Voltage: **220 / 240 V** (110V Vers. USA)
 Product Weight: **1,5 Kg / lbs 3**

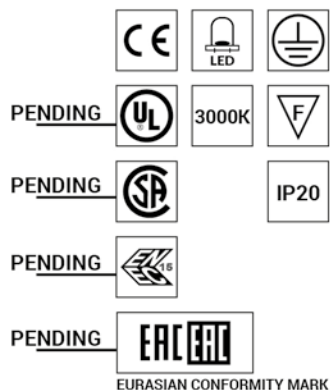

Disponibile in / Available in:

Colore Vetri / Glass Color

Trasparenti / Clear

CR	1	Cristallo Crystal	MA	7	Ametista Medio Medium Amethyst
MT	2	Topazio Medio Medium Topaz	DG	8	Grigio Grey
GG	3	Verde Erba Medio Medium Grass Green	CB	9	Blu Cobalto Cobalt Blue
MG	4	Verde Marino Chiaro Medium Marine Green	BL	10	Nero Black
DE	5	Verde Smeraldo Scuro Dark Emerald Green	MR	11	Rosso Medio Medium Red
DS	6	Acquamarina Scura Dark Sea Water			

Non Trasparenti / Solid

WM	12	Bianco White Milk	LG	18	Grigio Chiaro Light Grey
LG	13	Verde Pisello Light Green	IV	19	Avorio Ivory
NG	14	Verde Nilo Nile Green	PG	20	Grigio Perla Pearl Grey
BP	15	Pervinca Periwinkle	PP	21	Viola Purple
CS	16	Celeste Chiaro Clear Sky	PR	22	Rosso Porpora Chiaro Purple Red
DT	17	Turchese Scuro Dark Turquoise	DB	23	Marrone Scuro Dark Brown

Speciali / Special

LT GREY	29	Grigio Fumè Chiaro Smoky Light Grey	ST	35	Acciaio Trasp. Transp. Steel
DK GREY	30	Grigio Fumè Scuro Smoky Dark Grey	COR	36	Corniola Trasp. Transp. Carnelian
YEL	31	Giallo Limone Lemonish Yellow	AQUA	37	Acquamarina Trasp. Transp. Sea Water
VIOL	32	Violetto Violet	MC	38	Cristallo Specchiato Mirrored Crystal
GREY	33	Grigio Medio Medium Grey	GREEN	39	Verde Green
AM	34	Ametista Trasp. Transp. Amethyst			

Finiture / Finishing

A	Oro Lucido Glossy Gold Plated	G	Nero Opaco Matt Black RAL 9005
B	Cromo Lucido Glossy Chrome Plated	I	Bianco Opaco+Gomma Soft Matt White+Soft Rubber
C	Grigio Opaco Matt Grey RAL 7030	L	Ottone Brunito Burnished Brass
D	Beige Opaco Matt Beige RAL 1019	M	Acciaio Brunito Burnished Steel
E	Marrone Opaco Matt Brown RAL 8028	N	Bianco Verniciato White Painted
F	Bianco Opaco Matt White RAL 9003	O	Verniciatura Bronzo Bronze Painted

Lavorazioni / Techniques

PUL	PULEGOSO	RIG	RIGADIN
BAL	BALLOTON	SPIR	SPIRALE

REBÉGOLO





Rebègolo è una lampada vivace dalle forme spontanee e naturali, che dall'alto verso il basso scorrono fluidamente, variando in diametro e dimensioni, ed è una lanterna moderna che mescola la tradizione delle lampade orientali con quella della lanterna tipica veneziana. Queste linee di design, soffiato in un vetro robusto e raffinato, vanno a costituire una scultura, che rivela tutto l'estro di chi l'ha pensata per arricchire con un pezzo di vera arte la tua casa.

Rebègolo is a lamp with lively and spontaneous shapes, that top-down flow fluidly, varying in diameter and size, and is a modern lantern that mixes the tradition of oriental lamps with that of typical Venetian lantern. These lines of design, blown glass in a robust and refined, are not only a piece of furniture but a sculpture, which reveals the creativity of those who mean to enrich their home with a real piece of art.



REBÉGOLO
Fam. 1016

Photo: 2 Lights Lantern
Purple Glass / Matt White Painted TAL 9003
with Led lights
Ø 320 mm H 560 mm
Art. TF 1016 L1 / 2 / PP / WHITE









REBÉGOLO
Fam. 1016

Photo: Floor Lamp
Ivory Glass / Matt Beige RAL 1019
with Led lights
Ø 500 mm H 1400 mm
Art. TF 1016 RL / 1 IV / G / BEIGE





REBÉGOLO
Fam. 1016

Photo: Table
Ivory Glass / Matt Beige RAL 1019
Ø 750 mm H 800 mm
Art. TF 1016 T1 / IV / G / BEIGE

Fam. 1016

REBÈGOLO

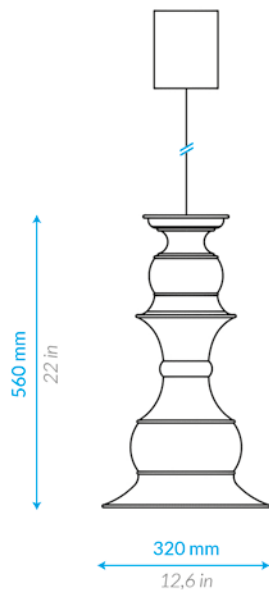

Lanterna 2 Luci

2 Lights Lantern

Item: **TF 1016 L1 / 2**

Light Source: **LED 1 x 9,3 W + 12 x 1,2 W**

Power: **24 W**

Voltage: **220 / 240 V** (110V Vers. USA)

Product Weight: **30 Kg / lbs 66**

Tavolo

Table

Item: **TF 1016 T1**

Product Weight: **72 Kg / lbs 159**

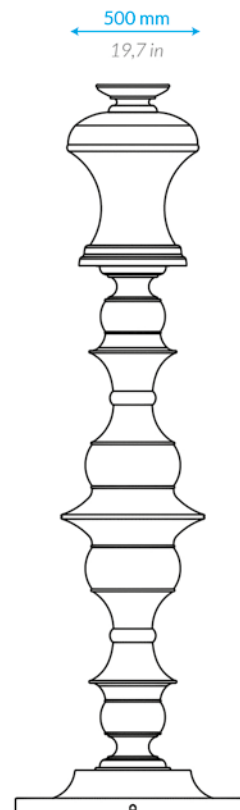
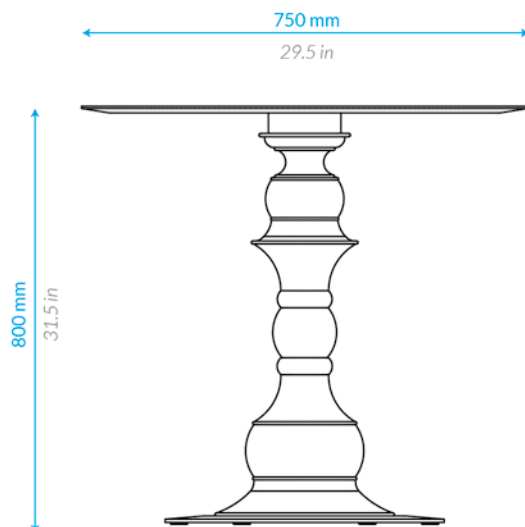

Lampada da Terra

Floor Lamp

Item: **TF 1016 RL1**

Light Source: **LED 1 x 7,4 W + 24 x 1,2 W**

Power: **36 W**

Voltage: **220 / 240 V** (110V Vers. USA)

Product Weight: **55 Kg / lbs 121**

Disponibile in / Available in:

Colore Vetri / Glass Color

Trasparenti / Clear

CR	1	Cristallo Crystal	MA	7	Ametista Medio Medium Amethyst
MT	2	Topazio Medio Medium Topaz	DG	8	Grigio Grey
GG	3	Verde Erba Medio Medium Grass Green	CB	9	Blu Cobalto Cobalt Blue
MG	4	Verde Marino Chiaro Medium Marine Green	BL	10	Nero Black
DE	5	Verde Smeraldo Scuro Dark Emerald Green	MR	11	Rosso Medio Medium Red
DS	6	Acquamarina Scura Dark Sea Water			

Non Trasparenti / Solid

WM	12	Bianco White Milk	LG	18	Grigio Chiaro Light Grey
LG	13	Verde Pisello Light Green	IV	19	Avorio Ivory
NG	14	Verde Nilo Nile Green	PG	20	Grigio Perla Pearl Grey
BP	15	Pervinca Periwinkle	PP	21	Viola Purple
CS	16	Celeste Chiaro Clear Sky	PR	22	Rosso Porpora Chiaro Purple Red
DT	17	Turchese Scuro Dark Turquoise	DB	23	Marrone Scuro Dark Brown

Speciali / Special

LT GREY	29	Grigio Fumè Chiaro Smokey Light Grey	ST	35	Acciaio Trasp. Transp. Steel
DK GREY	30	Grigio Fumè Scuro Smokey Dark Grey	COR	36	Corniola Trasp. Transp. Carnelian
YEL	31	Giallo Limone Lemonish Yellow	AQUA	37	Acquamarina Trasp. Transp. Sea Water
VIOL	32	Violetto Violet	MC	38	Cristallo Specchiato Mirrored Crystal
GREY	33	Grigio Medio Medium Grey	GREEN	39	Verde Green
AM	34	Ametista Trasp. Transp. Amethyst			

Finiture / Finishing

A	Oro Lucido Glossy Gold Plated	G	Nero Opaco Matt Black RAL 9005
B	Cromo Lucido Glossy Chrome Plated	I	Bianco Opaco+Gomma Soft Matt White+Soft Rubber
C	Grigio Opaco Matt Grey RAL 7030	L	Ottone Brunito Burnished Brass
D	Beige Opaco Matt Beige RAL 1019	M	Acciaio Brunito Burnished Steel
E	Marrone Opaco Matt Brown RAL 8028	N	Bianco Verniciato White Painted
F	Bianco Opaco Matt White RAL 9003	O	Verniciatura Bronzo Bronze Painted

Lavorazioni / Techniques

PUL	PULEGOSO	RIG	RIGADIN
BAL	BALLOTON	SPIR	SPIRALE

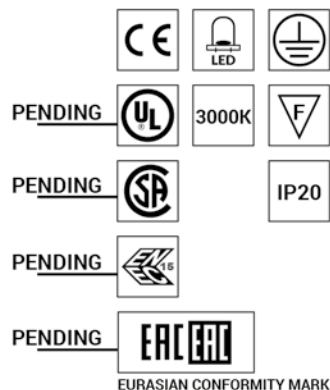
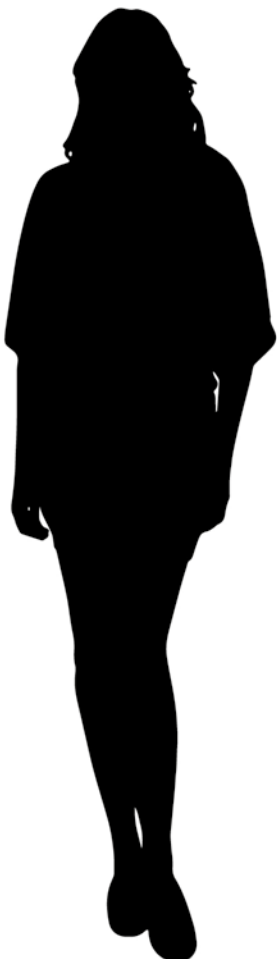

ARDENTE





Ardente è una lampada in vetro di Murano, che prende il suo nome non solo dalla materia rovente con la quale è plasmata, ma anche dal rosso intenso con cui è stata realizzata. Ardente mescola nelle linee, pulite e sinuose, la tradizionale forma della lanterna veneziana a quella di una slanciata ed elegante anfora moderna. All'accensione, il vetro e il cuore luminoso al suo interno, creano la stessa atmosfera avvolgente e suggestiva del tizzone in un camino.

Ardente is a Murano Glass lamp, that takes its name not only from the material by which molds it, but also for the red color with which it was made. Ardente mixes between its clean lines, the traditional form of Venetian lantern to that of a slender and binder modern amphora. The magic of Ardente occurs on power up, when the glass and its bright heart, together create the same enveloping and suggestive atmosphere of the embers in a fireplace.



ARDENTE
Fam. 1018

Photo: 2 Lights Lantern
Red Glass / Matt White Painted TAL 9003
with Led lights
Ø 150 mm H 180 mm
Art. TF 1018 L2 / 2 / PR / WHITE





Fam. 1018

ARDENTE

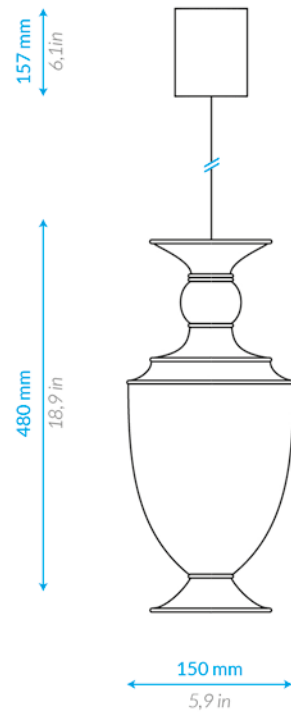

Lanterna 2 Luci *2 Lights Lantern*

Item: **TF 1018 L2 / 2**
Light Source: **LED 1 x 9,3 W + 12 x 1,2 W**
Power: **24 W**
Voltage: **220 / 240 V** (110V Vers. USA)
Product Weight: **28 Kg / lbs 62**

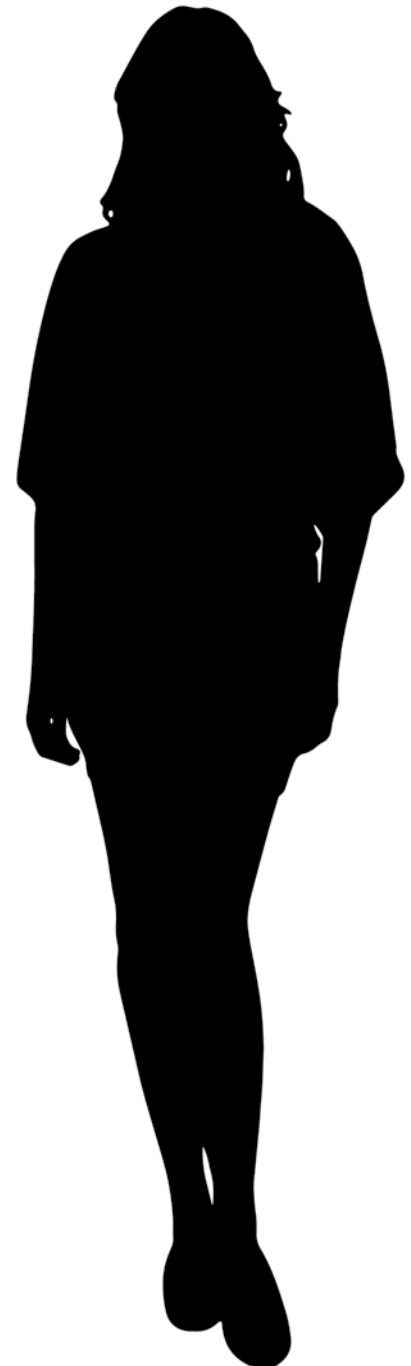

Disponibile in / Available in:

Colore Vetri / Glass Color

Trasparenti / Clear

CR		1	Cristallo Crystal	MA		7	Ametista Medio Medium Amethyst
MT		2	Topazio Medio Medium Topaz	DG		8	Grigio Grey
GG		3	Verde Erba Medio Medium Grass Green	CB		9	Blu Cobalto Cobalt Blue
MG		4	Verde Marino Chiaro Medium Marine Green	BL		10	Nero Black
DE		5	Verde Smeraldo Scuro Dark Emerald Green	MR		11	Rosso Medio Medium Red
DS		6	Acquamarina Scura Dark Sea Water				

Non Trasparenti / Solid

WM		12	Bianco White Milk	LG		18	Grigio Chiaro Light Grey
LG		13	Verde Pisello Light Green	IV		19	Avorio Ivory
NG		14	Verde Nilo Nile Green	PG		20	Grigio Perla Pearl Grey
BP		15	Pervinca Periwinkle	PP		21	Viola Purple
CS		16	Celeste Chiaro Clear Sky	PR		22	Rosso Porpora Chiaro Purple Red
DT		17	Turchese Scuro Dark Turquoise	DB		23	Marrone Scuro Dark Brown

Speciali / Special

LT GREY		29	Grigio Fumè Chiaro Smokey Light Grey	ST		35	Acciaio Trasp. Transp. Steel
DK GREY		30	Grigio Fumè Scuro Smokey Dark Grey	COR		36	Corniola Trasp. Transp. Carnelian
YEL		31	Giallo Limone Lemonish Yellow	AQUA		37	Acquamarina Trasp. Transp. Sea Water
VIOL		32	Violetto Violet	MC		38	Cristallo Specchiato Mirrored Crystal
GREY		33	Grigio Medio Medium Grey	GREEN		39	Verde Green
AM		34	Ametista Trasp. Transp. Amethyst				

Finiture / Finishing

A		Oro Lucido Glossy Gold Plated	G		Nero Opaco Matt Black RAL 9005
B		Cromo Lucido Glossy Chrome Plated	I		Bianco Opaco+Gomma Soft Matt White+Soft Rubber
C		Grigio Opaco Matt Grey RAL 7030	L		Ottone Brunito Burnished Brass
D		Beige Opaco Matt Beige RAL 1019	M		Acciaio Brunito Burnished Steel
E		Marrone Opaco Matt Brown RAL 8028	N		Bianco Verniciato White Painted
F		Bianco Opaco Matt White RAL 9003	O		Verniciatura Bronzo Bronze Painted

Lavorazioni / Techniques

PUL		PULEGOSO	RIG		RIGADIN
BAL		BALLOTON	SPIR		SPIRALE

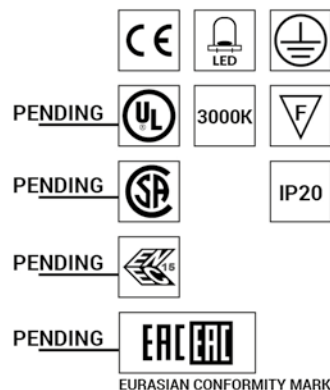

Fam. LS001

PARALUME / LAMP-SHADE

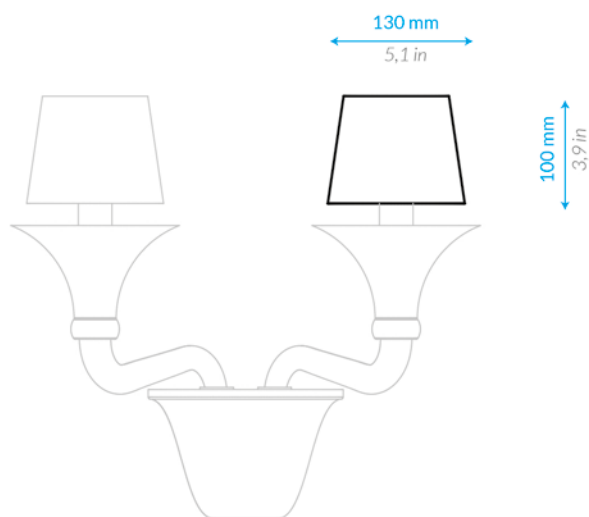

Paralume in tessuto
Fabric Lamp-shade

Item: **TFLS001**

Per Lampadario / Applique:

1001 - 1002 - 1005 - 1009

1011 - 1012 - 1014 - 1015

For Chandelier / Wall Lamp:

1001 - 1002 - 1005 - 1009

1011 - 1012 - 1014 - 1015

Disponibile in / Available in:

Colore Vetri / Glass Color

Trasparenti / Clear

CR	1	Cristallo Crystal	MA	7	Ametista Medio Medium Amethyst
MT	2	Topazio Medio Medium Topaz	DG	8	Grigio Grey
GG	3	Verde Erba Medio Medium Grass Green	CB	9	Blu Cobalto Cobalt Blue
MG	4	Verde Marino Chiaro Medium Marine Green	BL	10	Nero Black
DE	5	Verde Smeraldo Scuro Dark Emerald Green	MR	11	Rosso Medio Medium Red
DS	6	Acquamarina Scura Dark Sea Water			

Non Trasparenti / Solid

WM	12	Bianco White Milk	LG	18	Grigio Chiaro Light Grey
LG	13	Verde Pisello Light Green	IV	19	Avorio Ivory
NG	14	Verde Nilo Nile Green	PG	20	Grigio Perla Pearl Grey
BP	15	Pervinca Periwinkle	PP	21	Viola Purple
CS	16	Celeste Chiaro Clear Sky	PR	22	Rosso Porpora Chiaro Purple Red
DT	17	Turchese Scuro Dark Turquoise	DB	23	Marrone Scuro Dark Brown

Speciali / Special

LT GREY	29	Grigio Fumè Chiaro Smokey Light Grey	ST	35	Acciaio Trasp. Transp. Steel
DK GREY	30	Grigio Fumè Scuro Smokey Dark Grey	COR	36	Corniola Trasp. Transp. Carnelian
YEL	31	Giallo Limone Lemonish Yellow	AQUA	37	Acquamarina Trasp. Transp. Sea Water
VIOL	32	Violetto Violet	MC	38	Cristallo Specchiato Mirrored Crystal
GREY	33	Grigio Medio Medium Grey	GREEN	39	Verde Green
AM	34	Ametista Trasp. Transp. Amethyst			

Finiture / Finishing

A	Oro Lucido Glossy Gold Plated	G	Nero Opaco Matt Black RAL 9005
B	Cromo Lucido Glossy Chrome Plated	I	Bianco Opaco+Gomma Soft Matt White+Soft Rubber
C	Grigio Opaco Matt Grey RAL 7030	L	Ottone Brunito Burnished Brass
D	Beige Opaco Matt Beige RAL 1019	M	Acciaio Brunito Burnished Steel
E	Marrone Opaco Matt Brown RAL 8028	N	Bianco Verniciato White Painted
F	Bianco Opaco Matt White RAL 9003	O	Verniciatura Bronzo Bronze Painted





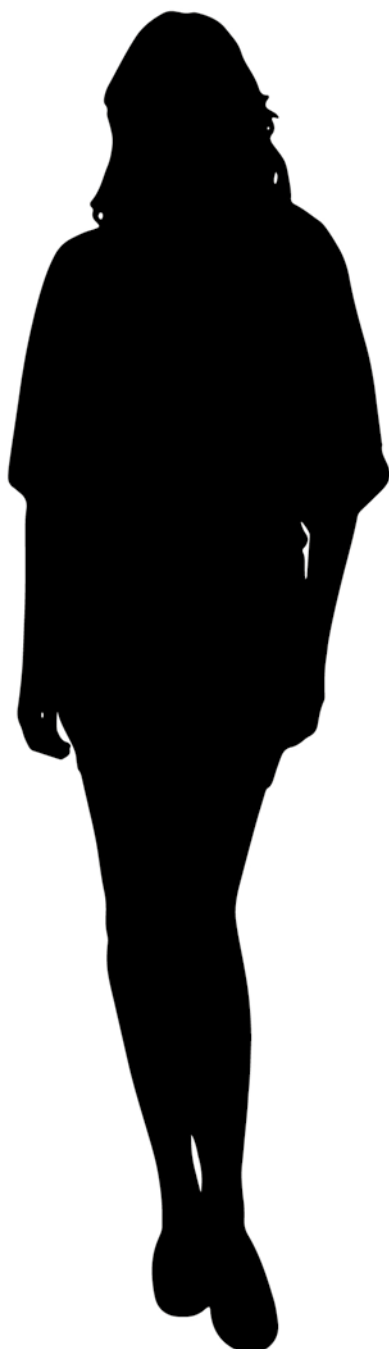





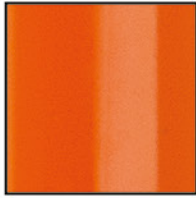



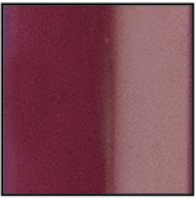



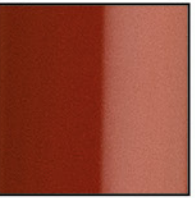
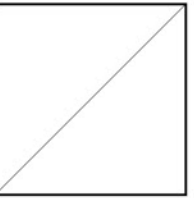



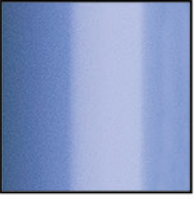



Lavorazioni / Techniques

PUL	PULEGOSO	RIG	RIGADIN
BAL	BALLOTON	SPIR	SPIRALE

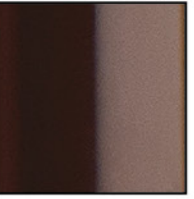

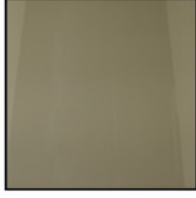
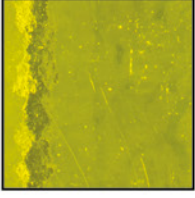
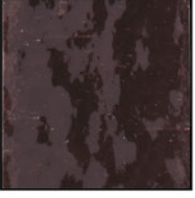
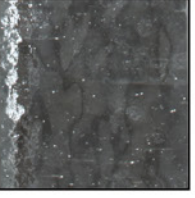
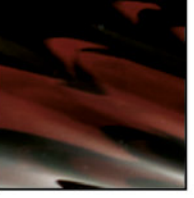

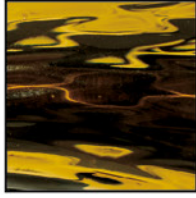
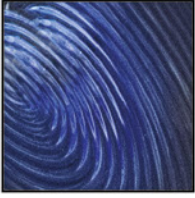

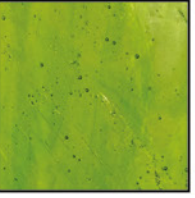
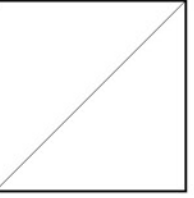



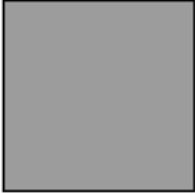

COLORI VETRI

Glass colors

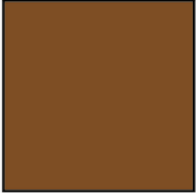
Trasparenti / Clear	CR 1  Cristallo Crystal	MT 2  Topazio Medio Medium Topaz	GG 3  Verde Erba Medio Medium Grass Green	MG 4  Verde Marino Chiaro Medium Marine Green	DE 5  Verde Smeraldo Scuro Dark Emerald Green	DS 6  Acquamarina Scura Dark Sea Water
	MA 7  Ametista Medio Medium Amethyst	DG 8  Grigio Grey	CB 9  Blu Cobalto Cobalt Blue	BL 10  Nero Black	MR 11  Rosso Medio Medium Red	
Non Trasparenti / Solid	WM 12  Bianco White Milk	LG 13  Verde Pisello Light Green	NG 14  Verde Nilo Nile Green	BP 15  Pervinca Periwinkle	CS 16  Celeste Chiaro Clear Sky	DT 17  Turchese Scuro Dark Turquoise
	LG 18  Grigio Chiaro Light Grey	IV 19  Avorio Ivory	PG 20  Grigio Perla Pearl Grey	PP 21  Viola Purple	PR 22  Rosso Porpora Chiaro Purple Red	DB 23  Marrone Scuro Dark Brown
Speciali / Special	LT GREY 29  Grigio Fumè Chiaro Smokey Light Grey	DK GREY 30  Grigio Fumè Scuro Smokey Dark Grey	YEL 31  Giallo Limone Lemonish Yellow	VIOL 32  Violetto Violet	GREY 33  Grigio Medio Medium Grey	AM 34  Ametista Trasp. Transp. Amethyst
	ST 35  Acciaio Trasp. Transp. Steel	COR 36  Corniola Trasp. Transp. Corniola	AQUA 37  Acquamarina Trasp. Transp. Sea Water	MC 38  Cristallo Specchiato Mirrored Crystal	GREEN 39  Verde Green	

FINITURE

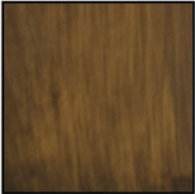
Finishing

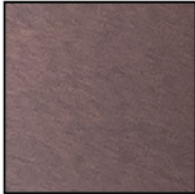
Finiture / Finishing	A	B	C RAL 7030	D RAL 1019	E RAL 8028	F RAL 9003
						
	Oro Lucido Glossy Gold Plated	Cromo Lucido Glossy Chrome Plated	Grigio Opaco Matt Grey RAL 7030	Beige Opaco Matt Beige RAL 1019	Marrone Opaco Matt Brown RAL 8028	Bianco Opaco Matt White RAL 9003
	G RAL 9005	I RAL 9003 + GS	L	M	N	O
						
	Nero Opaco Matt Black RAL 9005	Bianco Opaco+ Gomma Soft Matt White+Soft Rubber	Ottone Brunito Burnshed Brass	Acciaio Brunito Burnshed Steel	Bianco Verniciato White Painted	Verniciatura Bronzo Bronze Painted

LAVORAZIONI

Techniques

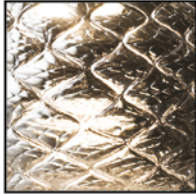
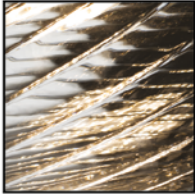
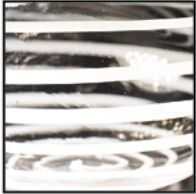
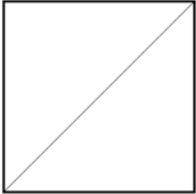
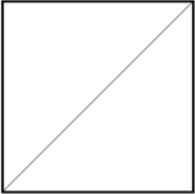
Lavorazioni / Techniques	PUL	BAL	RIG	SPIR		
						
	PULEGOSO	BALLOTON	RIGADIN	SPIRALE BIANCA		

ACQUARI

Collezione di opere uniche in vetro di Murano
realizzate a mano

*A Unique Murano Glass Collection
of hand-made glassworks*

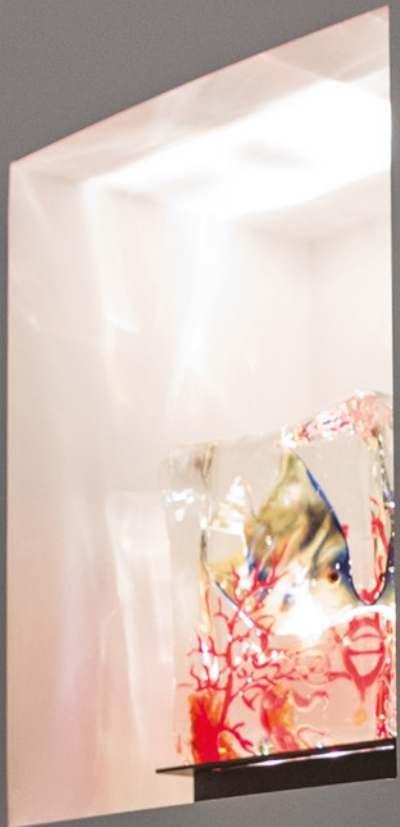









Accessory: **4001/ACC1**
Lighting pedestal

MURANO VENEZIA
ABATEZANETTI

Calle Briati 8/b - 30141
Murano Venezia - ITALIA
Tel: +39.0412737711
info@abatezanetti.it
www.abatezanetti.it

FOLLOW US

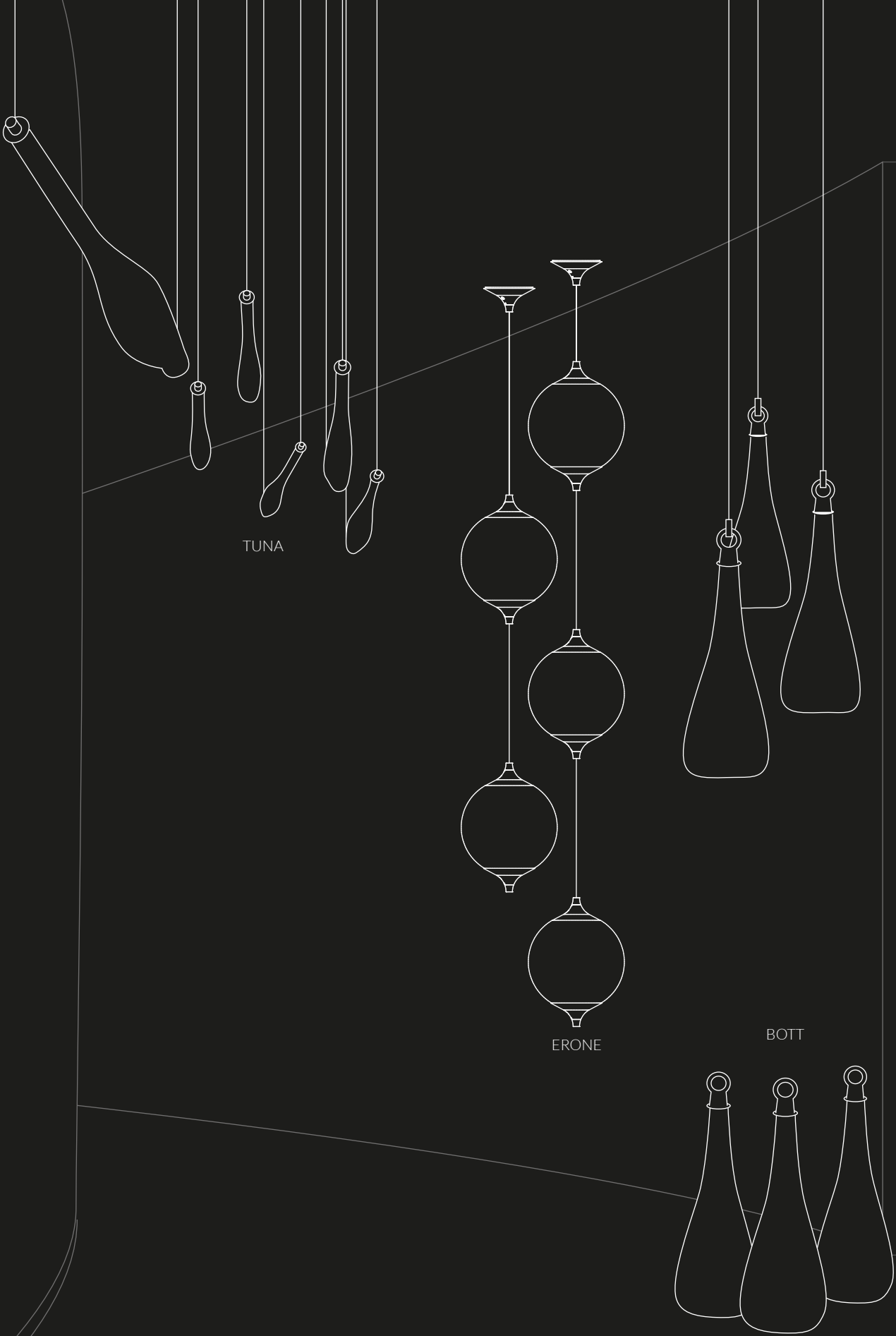

TUNA

ERONE

BOTT



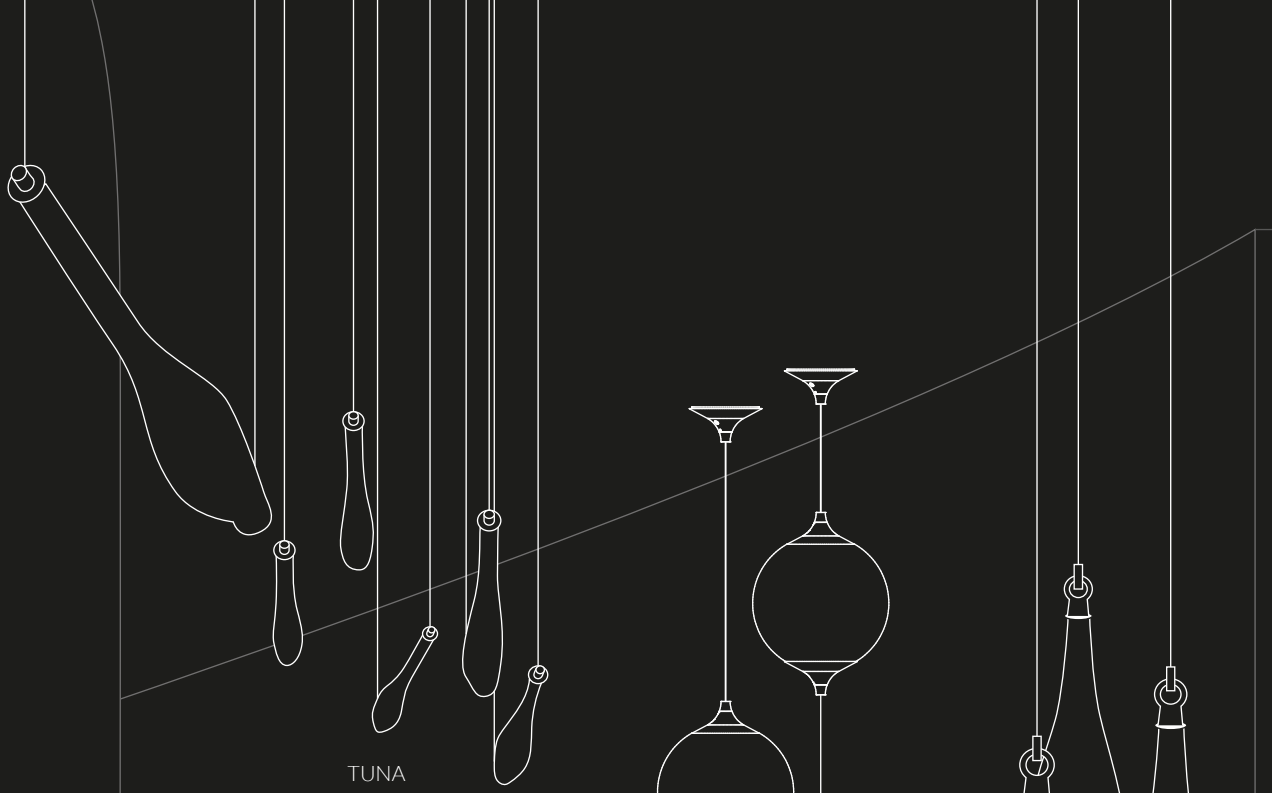

TUNA

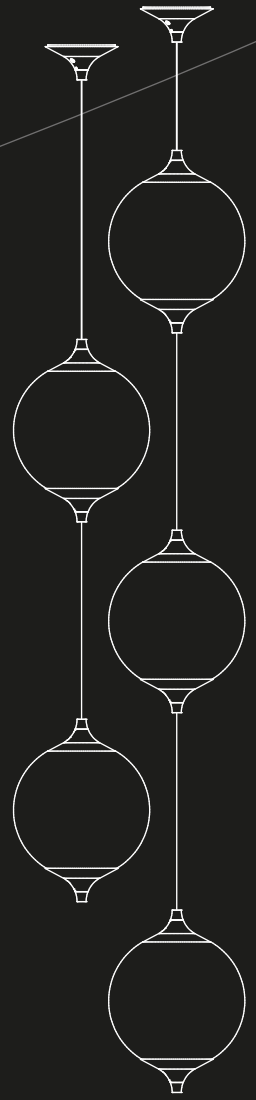

ERONE

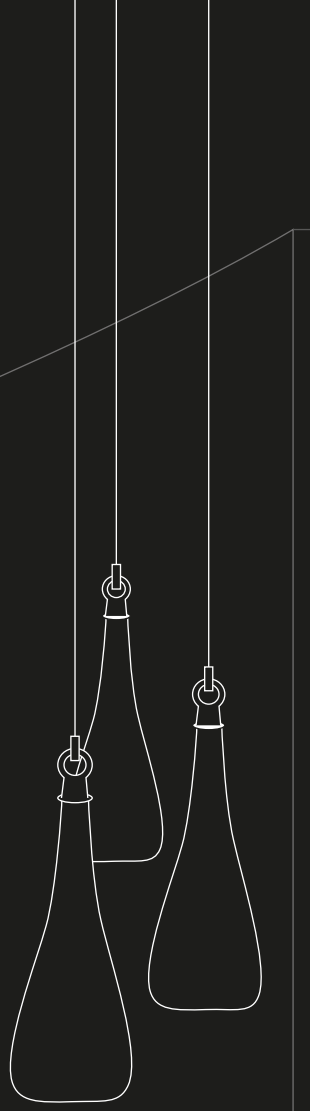

BOTT

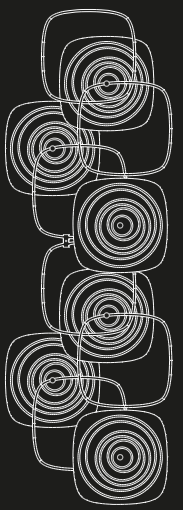

JIMMY



BELT

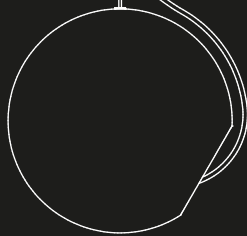
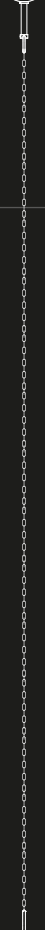

INNER



SUPERCAENA

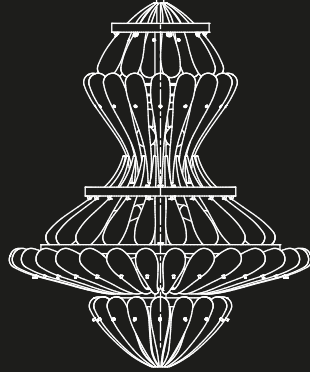

BALLERINO

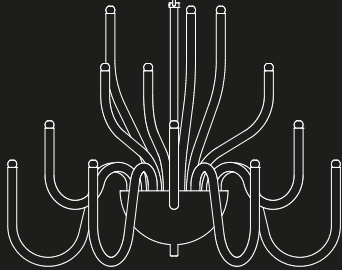

GORGONE

MALFATTO

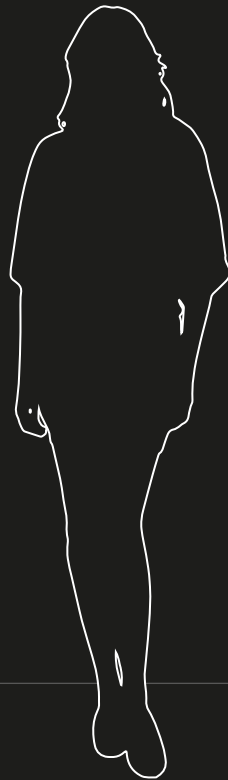
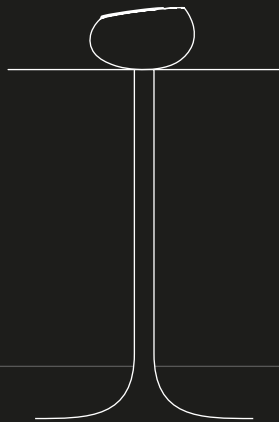

LIGHTING 2016



www.abatezanetti.it

MURANO
VENEZIA

ABBATEZZA

LI
GHI
N
G
2016